

**ROTAX®**

# INSTALLATION MANUAL

FOR ROTAX ENGINE TYPE 916 i A/C24 SERIES

REF NO.: IM-916 i A/C24 | PART NO.: 898874



## WARNING

**Before starting with engine installation, please read the Installation Manual completely as it contains important safety relevant information.**

This Installation Manual for the ROTAX® aircraft engines should only be used as a general installation guide for the installation of ROTAX® engines into airframes. It should not be used as instruction for the installation of a ROTAX® aircraft engine in a specific type of airframe or airplane. BRP-Rotax GmbH & Co KG does not assume any warranty or liability in this context.

In no event shall the Installation Manual be used without following the specific instructions and/or requirements of the manufacture of an airframe or airplane ("Manufacturer"). For verification and/or for release of the engine installation, the respective Manufacturer must be contacted. Any modifications or adaptations to the airframe or airplane shall be carried out and/or be verified and released by the Manufacturer only.

Improper use of the Installation Manual and/or non compliance with the installation requirements of the Manufacturers can cause personal injury or property damage. BRP-Rotax GmbH & Co. KG disclaims any liability for any and all damage and/or injuries (including death) resulting from the improper use of Installation Manual and non compliance with the installation requirements of the Manufacturer.

These technical data and the information embodied therein are the property of BRP-Rotax GmbH & CO KG, Austria, acc. BGBl 1984 no. 448, and shall not, without prior written permission of BRP-Rotax GmbH & Co KG, be disclosed in whole or in part to third parties. This legend shall be included on any reproduction of these data, in whole or in part. The Manual must remain with the engine/aircraft in case of sale.

Copyright 2023 © - all rights reserved.

Translation into other languages might be performed in the course of language localization but does not lie within ROTAX® scope of responsibility. In any case the original text in English language and the metric units are authoritative.

**BRP-Rotax**  
INSTALLATION MANUAL

## Table of Content

<b>Chapter</b>	<b>INTRO – GENERAL NOTE</b>
<b>Chapter</b>	<b>LEP – LIST OF EFFECTIVE PAGES</b>
<b>Chapter</b>	<b>TOA – TABLE OF AMENDMENTS</b>
<b>Chapter</b>	<b>00–00–00 – GENERAL NOTE</b>
<b>Chapter</b>	<b>10–10–00 – STORAGE AND INSTALLATION</b>
<b>Chapter</b>	<b>24–00–00 – ELECTRICAL POWER</b>
<b>Chapter</b>	<b>61–00–00 – PROPELLER DRIVE</b>
<b>Chapter</b>	<b>72–00–00 – ENGINE</b>
<b>Chapter</b>	<b>72–60–00 – AIR INTAKE SYSTEM</b>
<b>Chapter</b>	<b>73–00–00 – ENGINE – FUEL AND CONTROL</b>
<b>Chapter</b>	<b>75–00–00 – COOLING SYSTEM</b>
<b>Chapter</b>	<b>76–00–00 – ENGINE CONTROLS</b>
<b>Chapter</b>	<b>77–00–00 – ENGINE INDICATING</b>
<b>Chapter</b>	<b>78–00–00 – EXHAUST SYSTEM</b>
<b>Chapter</b>	<b>79–00–00 – LUBRICATION SYSTEM</b>
<b>Chapter</b>	<b>80–00–00 – STARTING</b>
<b>Chapter</b>	<b>92–00–00 – WIRING DIAGRAMS</b>

**BRP-Rotax**  
INSTALLATION MANUAL

INTENTIONALLY LEFT  
BLANK

# BRP-Rotax INSTALLATION MANUAL

## Chapter: INTRO GENERAL NOTE

### Foreword

Before carrying out engine installation related work on the engine, read this Installation Manual carefully. The manual will provide you with basic information on correct engine installation for safe engine operation.

If any passages of the manual are not clearly understood or if you have any questions, please contact a ROTAX® authorized distributor or their independent Service Center for ROTAX® aircraft engines.

BRP-Rotax GmbH & Co KG (hereinafter "BRP-Rotax") wishes you much pleasure and satisfaction flying your aircraft powered by this ROTAX® aircraft engine.

The structure of the manual follows, whenever possible, the structure of the ATA (Air Transport Association) standards. The aim is the compatibility with the aircraft manufacturers documentation, which means they still must adapt or incorporate the documentation to their standard.

**BRP-Rotax**  
INSTALLATION MANUAL

INTENTIONALLY LEFT  
BLANK

**BRP-Rotax  
INSTALLATION MANUAL**

**Chapter: LEP  
LIST OF EFFECTIVE PAGES**

Each new revision to the Installation Manual will have a new List of Effective Pages.

Chapter	Page	Date
	Title page	
INTRO	1	December 01 2023
	2	December 01 2023
LEP	1	December 01 2023
	2	December 01 2023
	3	December 01 2023
	4	December 01 2023
TOA	1	December 01 2023
	2	December 01 2023
	3	December 01 2023
	4	December 01 2023
00-00-00	1	December 01 2023
	2	December 01 2023
	3	December 01 2023
	4	December 01 2023
	5	December 01 2023
	6	December 01 2023
	7	December 01 2023
	8	December 01 2023
	9	December 01 2023
	10	December 01 2023
	11	December 01 2023
	12	December 01 2023
	13	December 01 2023
	14	December 01 2023
	15	December 01 2023
	16	December 01 2023
	17	December 01 2023
	18	December 01 2023

Chapter	Page	Date
	19	December 01 2023
	20	December 01 2023
10-10-00	1	December 01 2023
	2	December 01 2023
	3	December 01 2023
	4	December 01 2023
	5	December 01 2023
	6	December 01 2023
	7	December 01 2023
	8	December 01 2023
	9	December 01 2023
	10	December 01 2023
24-00-00	1	December 01 2023
	2	December 01 2023
	3	December 01 2023
	4	December 01 2023
	5	December 01 2023
	6	December 01 2023
	7	December 01 2023
	8	December 01 2023
	9	December 01 2023
	10	December 01 2023
	11	December 01 2023
	12	December 01 2023
	13	December 01 2023
	14	December 01 2023
	15	December 01 2023
	16	December 01 2023
	17	December 01 2023

**BRP-Rotax**  
INSTALLATION MANUAL

Chapter	Page	Date	Chapter	Page	Date
	18	December 01 2023		11	December 01 2023
	19	December 01 2023		12	December 01 2023
	20	December 01 2023		13	December 01 2023
	21	December 01 2023		14	December 01 2023
	22	December 01 2023	72-60-00	1	December 01 2023
	23	December 01 2023		2	December 01 2023
	24	December 01 2023		3	December 01 2023
	25	December 01 2023		4	December 01 2023
	26	December 01 2023		5	December 01 2023
	27	December 01 2023		6	December 01 2023
	28	December 01 2023		7	December 01 2023
	29	December 01 2023		8	December 01 2023
	30	December 01 2023		9	December 01 2023
61-00-00	1	December 01 2023		10	December 01 2023
	2	December 01 2023	73-00-00	1	December 01 2023
	3	December 01 2023		2	December 01 2023
	4	December 01 2023		3	December 01 2023
	5	December 01 2023		4	December 01 2023
	6	December 01 2023		5	December 01 2023
	7	December 01 2023		6	December 01 2023
	8	December 01 2023		7	December 01 2023
	9	December 01 2023		8	December 01 2023
	10	December 01 2023		9	December 01 2023
72-00-00	1	December 01 2023		10	December 01 2023
	2	December 01 2023		11	December 01 2023
	3	December 01 2023		12	December 01 2023
	4	December 01 2023		13	December 01 2023
	5	December 01 2023		14	December 01 2023
	6	December 01 2023	75-00-00	1	December 01 2023
	7	December 01 2023		2	December 01 2023
	8	December 01 2023		3	December 01 2023
	9	December 01 2023		4	December 01 2023
	10	December 01 2023		5	December 01 2023



**BRP-Rotax**  
INSTALLATION MANUAL

Chapter	Page	Date
	6	December 01 2023
	7	December 01 2023
	8	December 01 2023
	9	December 01 2023
	10	December 01 2023
	11	December 01 2023
	12	December 01 2023
	13	December 01 2023
	14	December 01 2023
	15	December 01 2023
	16	December 01 2023
76-00-00	1	December 01 2023
	2	December 01 2023
	3	December 01 2023
	4	December 01 2023
	5	December 01 2023
	6	December 01 2023
	7	December 01 2023
	8	December 01 2023
	9	December 01 2023
	10	December 01 2023
	11	December 01 2023
	12	December 01 2023
	13	December 01 2023
	14	December 01 2023
	15	December 01 2023
	16	December 01 2023
	17	December 01 2023
	18	December 01 2023
	19	December 01 2023
	20	December 01 2023
77-00-00	1	December 01 2023
	2	December 01 2023

Chapter	Page	Date
	3	December 01 2023
	4	December 01 2023
	5	December 01 2023
	6	December 01 2023
	7	December 01 2023
	8	December 01 2023
	9	December 01 2023
	10	December 01 2023
	11	December 01 2023
	12	December 01 2023
	13	December 01 2023
	14	December 01 2023
	15	December 01 2023
	16	December 01 2023
	17	December 01 2023
	18	December 01 2023
	19	December 01 2023
	20	December 01 2023
78-00-00	1	December 01 2023
	2	December 01 2023
	3	December 01 2023
	4	December 01 2023
	5	December 01 2023
	6	December 01 2023
79-00-00	1	December 01 2023
	2	December 01 2023
	3	December 01 2023
	4	December 01 2023
	5	December 01 2023
	6	December 01 2023
	7	December 01 2023
	8	December 01 2023
	9	December 01 2023

**BRP-Rotax**  
INSTALLATION MANUAL

Chapter	Page	Date
	10	December 01 2023
	11	December 01 2023
	12	December 01 2023
	13	December 01 2023
	14	December 01 2023
	15	December 01 2023
	16	December 01 2023
	17	December 01 2023
	18	December 01 2023
	19	December 01 2023
	20	December 01 2023
80-00-00	1	December 01 2023
	2	December 01 2023
	3	December 01 2023

Chapter	Page	Date
	4	December 01 2023
	5	December 01 2023
	6	December 01 2023
	7	December 01 2023
	8	December 01 2023
	9	December 01 2023
	10	December 01 2023
	11	December 01 2023
	12	December 01 2023
92-00-00	1	December 01 2023
	2	December 01 2023
	Index	
	Back page	

**BRP-Rotax**  
INSTALLATION MANUAL

**Chapter: TOA**  
**TABLE OF AMENDMENTS**

**Approval\***  
The technical content of this document is approved under the authority of the DOA ref. EASA.21.J.048.

Edition 0/Rev. 0 July 01 2023

Obsolete with Revision 1, which is a complete re-revision

Revision 1 December 01 2023

Current no.	Chapter	Page	Date of change	Remark for approval	Date of approval from authorities	Date of inclusion	Signature
0	INTRO	all	July 01 2023	DOA*			
0	LEP	all	July 01 2023	DOA*			
0	TOA	all	July 01 2023	DOA*			
0	00-00-00	all	July 01 2023	DOA*			
0	10-10-00	all	July 01 2023	DOA*			
0	24-00-00	all	July 01 2023	DOA*			
0	61-00-00	all	July 01 2023	DOA*			
0	72-00-00	all	July 01 2023	DOA*			
0	72-60-00	all	July 01 2023	DOA*			
0	73-00-00	all	July 01 2023	DOA*			
0	75-00-00	all	July 01 2023	DOA*			
0	76-00-00	all	July 01 2023	DOA*			
0	77-00-00	all	July 01 2023	DOA*			
0	78-00-00	all	July 01 2023	DOA*			
0	79-00-00	all	July 01 2023	DOA*			
0	80-00-00	all	July 01 2023	DOA*			
0	92-00-00	all	July 01 2023	DOA*			

**BRP-Rotax**  
INSTALLATION MANUAL

Current no.	Chapter	Page	Date of change	Remark for approval	Date of approval from authorities	Date of inclusion	Signature
1	LEP	all	Dec. 01 2023	DOA*			
1	TOA	all	Dec. 01 2023	DOA*			
1	00-00-00	3,20	Dec. 01 2023	DOA*			
1	24-00-00	all	Dec. 01 2023	DOA*			
1	61-00-00	7	Dec. 01 2023	DOA*			
1	72-00-00	11	Dec. 01 2023	DOA*			
1	73-00-00	5,7	Dec. 01 2023	DOA*			
1	76-00-00	3,4,6, 10–13 18,19	Dec. 01 2023	DOA*			
1	77-00-00	3,9–12 16–19	Dec. 01 2023	DOA*			
1	78-00-00	5,	Dec. 01 2023	DOA*			
1	80-00-00	4–7	Dec. 01 2023	DOA*			
1	92-00-00	1	Dec. 01 2023	DOA*			

# BRP-Rotax INSTALLATION MANUAL

## Summary of amendments

Summary of the relevant amendments in this context, but without any claim to completeness.

Current no.	Chapter	Page	Date of change	Comment
1	all	-	December 01 2023	New additional designation of engine type (C24)

**BRP-Rotax**  
INSTALLATION MANUAL

INTENTIONALLY LEFT  
BLANK

**BRP-Rotax**  
**INSTALLATION MANUAL**

**Chapter: 00-00-00**  
**GENERAL NOTE**

**TOPICS IN THIS CHAPTER**

<b>General</b> .....	<b>2</b>
<b>Type description</b> .....	<b>3</b>
<b>Scope of supply</b> .....	<b>4</b>
<b>Auxiliary equipment (optional)</b> .....	<b>5</b>
<b>Abbreviations and terms (depending on respective engine type)</b> .....	<b>6</b>
Wiring color codes .....	11
Conversion table .....	12
<b>Safety notice</b> .....	<b>13</b>
Safety information .....	14
Instruction .....	16
<b>Technical documentation</b> .....	<b>17</b>
<b>Approval of electric and electronic components (Equipment Qualification according to RTCA/DO-160)</b> .....	<b>19</b>

# BRP-Rotax INSTALLATION MANUAL

## GENERAL

### **Purpose**

The purpose of this Manual is to provide aircraft manufacturers with technical requirements (e.g. interface descriptions and limitations) that must be adhered to when installing this type of engine into an aircraft or certifying aircraft powered by this engine type. Furthermore it should allow independent ROTAX® Maintenance Technicians (iRMT) to install this engine into an airframe in compliance with the relevant installation and safety instructions provided by the engine manufacturer.

For detailed information related to aircraft and aircraft/engine installation, maintenance, safety or flight operation, consult the documentation provided by the aircraft manufacturer and/or its dealer.

For additional information on engines, its maintenance or parts, you can also contact your nearest ROTAX® authorized Aircraft Engine Distributor or their independent Service Center.

### **ROTAX Distributors**

For ROTAX® Authorized Distributors for aircraft engines see latest Operators Manual (OM) or the official website [www.FLYROTAX.com](http://www.FLYROTAX.com).

### **Engine serial number**

When making inquiries or ordering parts, always indicate the engine serial number. Due to continuous product improvement, engines of the same engine type might require different support and spare parts.

The engine serial number is on top of the crankcase, behind the propeller gearbox.

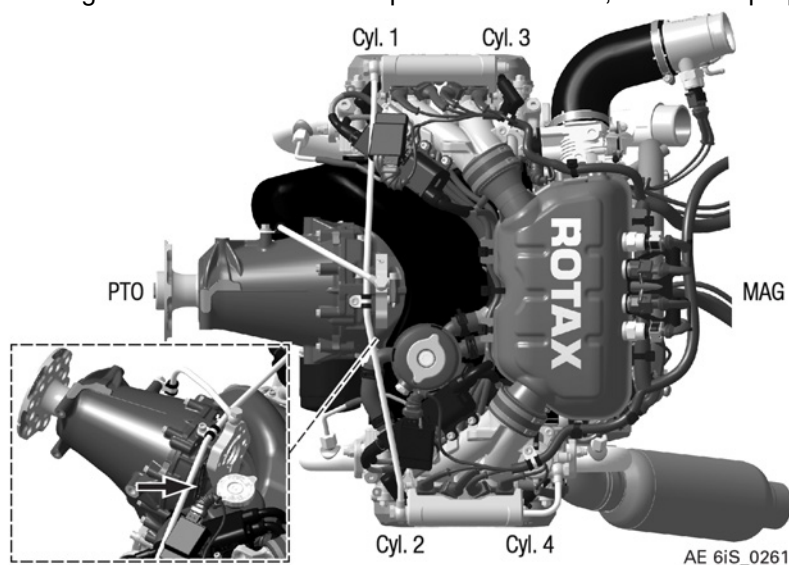

Figure 1.1: Engine serial number





# BRP-Rotax INSTALLATION MANUAL

## SCOPE OF SUPPLY

### **Basic**

- 4- stroke-, 4 cylinder horizontally opposed-, spark ignition engine, single central cam-shaft push rods —OHV (Over Head Valve)
- Liquid cooled cylinder heads
- Ram air cooled cylinders
- Dry sump forced lubrication
- Fully redundant electronic engine management system (EMS) for controlling fuel injection, ignition, etc.
- Propeller drive via gearbox with integrated torsional vibration absorber and overload clutch
- Oil tank
- Electric starter
- Turbocharger
- Electronic/pneumatic control of boost pressure
- Exhaust system

### **Optional**

- Accessory drive for hydraulic propeller governor (configuration 3 only)
- Cooling air baffle

# BRP-Rotax INSTALLATION MANUAL

## **AUXILIARY EQUIPMENT (OPTIONAL)**

Any equipment not included as part of the standard engine version and thus not a fix component of the engine is not in the volume of supply.

Components especially developed and tested for this engine are readily available at BRP-Rotax.

### **Auxiliary equipment certified**

The following auxiliary equipment has been developed and tested for this engine.

- See relevant Illustrated Parts Catalog (IPC)

### **Auxiliary equipment not certified**



The following auxiliary equipment has been developed and tested, but NOT certified for this engine. Certification of auxiliary equipment is the responsibility of the aircraft manufacturer.

- See relevant Illustrated Parts Catalog (IPC)

The representation of components that are not within scope of the delivery is purely symbolic. It does not constitute the specification of the engine version and shall therefore only be seen functionally. The actual interpretation/selection of corresponding regulations is the aircraft manufacturer's responsibility.

**BRP-Rotax**  
**INSTALLATION MANUAL**

**ABBREVIATIONS AND TERMS (DEPENDING ON RESPECTIVE ENGINE TYPE)**

Abbreviations	Description
*	Reference to another section
	center of gravity
	The drop symbol indicates use of sealing agents, adhesives or lubricants (only in the Maintenance Manual Heavy)
°C	Degrees Celsius (Centigrade)
°F	Degrees Fahrenheit
rpm	Revolutions per minute
A	Ampere
AAPTS	Ambient Air Pressure Temperature Sensor
AC	alternating current
AD	Airworthiness Directives
Ah	Ampere hour
A/C	Aircraft
AC-DC	EMS Modul voltage converter
AR	as required
assy.	assembly
ASB	Alert Service Bulletin
ACG	Austro Control GmbH
ACL	Anti Collision Light
API	American Petrol Institute
ASTM	American Society for Testing and Materials
ATA	Air Transport Association
AWG	American Wire Gauge
CAN	Controller Area Network
CCS	Camshaft position sensor
Coil 1–4	Ignition coils 1–4
CPS 1+2	Crankshaft Position Sensor 1+2
CSA	Constant Speed Actuator
CTS	Cooling Temperature Sensor

# BRP-Rotax INSTALLATION MANUAL

Abbreviations	Description
CW	clockwise
CCW	counter-clockwise
CGSB	Canadian General Standards Board
DCDI	Dual Capacitor Discharge Ignition
DC	direct current
DOA	Design Organisation Approval
DOT	Department of Transport
EASA	European Aviation Safety Agency
IM	Installation Manual
ECU	Engine Control Unit
EGT	Exhaust Gas Temperature
INTRO	Introduction
EMS	Engine Management System
EMS GND	Engine system internal ground reference which is intended to be disconnected from aircraft common ground during flight
EMC	Electromagnetic compatibility
EN	European Standard
ETFE	Ethylene Tetrafluoroethylene
FAA	Federal Aviation Administration
FAR	Federal Aviation Regulations
FOD	Foreign object damage
FL	Flight Level
Fuse box	Power conditioning and distribution for the Engine Management System
hr.	hours
HIC A	Harness Interface Connector A
HIC B	Harness Interface Connector B
IAT	Indicated Air Temperature
ICA	Instructions for Continued Airworthiness
IFR	Instrument Flight Rules
IFSD	In-flight-shutdown
INJ 1–8	Injector 1–8

## BRP-Rotax INSTALLATION MANUAL

<b>Abbreviations</b>	<b>Description</b>
IPC	Illustrated Parts Catalog
ips	inch per second
iRMT	independent ROTAX Maintenance Technician
ISA	International Standard Atmosphere
kg	Kilograms
KNOCK	Knock sensor
Lane A	System A of Engine Management System
Lane B	System B of Engine Management System
LOPC	Loss of power control
MAPS 1 & 2	Manifold Air Pressure Sensor 1 & 2
MATS 1 & 2	Manifold Air Temperature Sensor 1 & 2
MON	Motor Octane Number
MAG	Magneto Side
N	Newton
n.a.	not available
NDT	Non Destructive Testing
NEW	Part must be replaced against NEW (mentioned in figures)
Nm	Newtonmeter
NVFR	Night Visual Flight Rules
OAT	Outside Air Temperature
OHM	Overhaul Manual
OHV	Over Head Valve
OM	Operators Manual
OPS	Oil Pressure Sensor
OTS	Oil Temperature Sensor
PCD	Pitch Circle Diameters
PCV	Pressure Control Valve
PMA	Permanent magnet alternator
POA	Production Organization Approval
PS	Power supply
PTFE	Polytetrafluoroethylene (Teflon)

# BRP-Rotax INSTALLATION MANUAL

Abbreviations	Description
PTO	Power Take Off
Rev.	Revision
ROTAX®	is a trademark of BRP-Rotax GmbH & Co KG
RON	Research Octane Number
RON 424	ROTAX® Standard 424
s.v.	still valid (only Illustrated Parts Catalog)
S/N	Serial Number
SAE	Society of Automotive Engineers
SEP	Single Engine Piston
SB	Service Bulletin
SI	Service Instruction
SI-PAC	Service Instruction Parts and Accessories
SPST	Single pole single throw
STP	Shielded twisted pair wire
SL	Service Letter
SMD	Surface Mounted Devices
TBO	Time Between Overhaul
TC	Type certificate
part no.	part number
TOA	Table Of Amendments
TOC	Table Of Contents
TPS	Throttle Position Sensor
TSN	Time Since New
TSNP	Time Since New Part
TSO	Time Since Overhaul
V	Volt
VFR	Visual Flight Rules
LEP	List of Effective Pages
MM	Maintenance Manual
MEP	Multi Engine Piston

**BRP-Rotax**  
INSTALLATION MANUAL

















<b>Abbreviations</b>	<b>Description</b>
X3	Connector on Engine Management System wiring harness which serves as an interface for power supply
XXXX	shows the component serial number



WIRING COLOR CODES

# IEC 60757

## Color codes (wiring)

black		BK
brown		BN
red		RD
orange		OG
yellow		YE
green		GN
blue		BU
violet		VT
gray		GY
white		WH
pink		PK
turquoise		TQ
Light blue		LBU
Dark blue		DBU
gold		GD
silver		SR
green-yellow		GNYE

10336

Figure 1.2

**BRP-Rotax**  
INSTALLATION MANUAL

**CONVERSION TABLE**

<b>Units of length:</b>	<b>Units of power:</b>
1 mm = 0.03937 in 1 in = 25.4 mm 1 ft = 12 in = 0.3048 m	1 kW = 1.341 hp 1 hp = 0.7457 kW 1 kW = 1.3596 PS 1 PS = 0.7355 kW
<b>Units of area:</b>	<b>Units of temperature:</b>
1 cm <sup>2</sup> = 0.155 sq. in (in <sup>2</sup> ) 1 sq. in (in <sup>2</sup> ) = 6.4516 cm <sup>2</sup>	K = °C – 273,15 °C = (°F – 32) / 1,8 °F = (°C x 1.8) +32
<b>Units of volume:</b>	<b>Units of velocity:</b>
1 cm <sup>3</sup> = 0.06102 cu in (in <sup>3</sup> ) 1 cu in (in <sup>3</sup> ) = 16.3871 cm <sup>3</sup> 1 dm <sup>3</sup> = 1 l 1 dm <sup>3</sup> = 0.21997 gal (UK) 1 gal (UK) = 4.5461 dm <sup>3</sup> 1 dm <sup>3</sup> = 0.26417 gal (US) 1 gal (US) = 3.7854 dm <sup>3</sup>	1 m/s = 3.6 km/h 1 ft/min = 0.3048 m/min = 0.00508 m/sec 1 m/s = 196.85 ft/min 1 kt = 1.852 km/h 1 km/h = 0.53996 kn
<b>Units of mass:</b>	<b>spec. fuel consumption:</b>
1 kg = 2.2046 lbs. 1 lb. = 0.45359 kg	1 g/kWh = 0.001644 lb/hph 1 lb/hph = 608.277 g/kWh
<b>Density:</b>	<b>Units of torque:</b>
1 g/cm <sup>3</sup> = 0.016018 lb/ft <sup>3</sup> 1 lb/ft <sup>3</sup> = 62.43 g/cm <sup>3</sup>	1 Nm = 0.737 ft lb = 8.848 in lb 1 ft lb = 1.356 Nm 1 in lb = 0.113 Nm
<b>Units of force:</b>	<b>Cable cross-section: Conversion table- Wire Gauge: AWG-mm<sup>2</sup></b>
1 N = 0.224809 lbf 1 lbf = 4.4482 N	AWG → mm <sup>2</sup> 4 → 21 6 → 13 8 → 8.4 10 → 5.3 12 → 3.3 14 → 2.1 16 → 1.3 18 → 0.8 20 → 0.52
<b>Units of pressure:</b>	
1 Pa = 1 N/m <sup>2</sup> 1 bar = 100 000 Pa / 1000 hPa / 100 kPa 1 bar = 14.503 lbf/in <sup>2</sup> (psi) 1 in Hg = 33.8638 hPa	

# BRP-Rotax INSTALLATION MANUAL

## **SAFETY NOTICE**

Although reading such information does not eliminate any hazards, it promotes understanding, and applying of the information will promote correct use of the engine. Always apply common workshop safety rules.

The information and descriptions of components and systems contained in this Manual are correct at the time of publication. BRP-Rotax maintains a policy of continuous improvement of its products without imposing upon itself any obligation to retrofit products previously manufactured.

### **Revisions**

BRP-Rotax reserves the right to remove, replace or discontinue any design, specification, feature or other at any time, and without incurring obligation.

### **Measurement**

Specifications are given in the SI metric system with the imperial- and US customary measurement system equivalents in parenthesis.

### **Symbols used**

This Manual uses the following symbols to emphasize particular information. This information is important and must be observed.

#### **⚠ WARNING**

**Identifies an instruction which, if not followed, may cause serious injury or even fatal injury.**

#### **⚠ CAUTION**

**Identifies an instruction which, if not followed, may cause minor or moderate injury.**

#### **NOTICE**

**Identifies an instruction which, if not followed, may severely damage the engine or could void any warranty.**

### **NOTE**

*Indicates supplementary information which may be needed to fully complete or understand an instruction.*

#### **ENVIRONMENTAL NOTE**

**Environmental notes give you tips on environmental protection.**

A revision bar outside the page margin indicates a change to text or graphic.

# BRP-Rotax INSTALLATION MANUAL

## SAFETY INFORMATION

Use for intended  
purpose

### **⚠ WARNING**

#### **Non-compliance can result in serious injuries or death!**

The user has to assume all risks possibly arising from utilizing auxiliary equipment.

### **⚠ WARNING**

#### **Non-compliance can result in serious injuries or death!**

Never fly the aircraft equipped with this engine at locations, air speeds, altitudes or in other situations which do not allow a successful no-power landing after sudden engine stoppage.

- This engine is not suitable for aerobatics (inverted flight, etc.). Flight attitudes outside the permissible limits are not allowed
- This engine has exclusively been developed and tested for fixed wing, gyrocopter, pusher and tractor applications. In case of any other usage, the OEM is responsible for testing and the correct function of the engine
- It should be clearly understood that the choice, selection and use of this particular engine on any aircraft is at the sole discretion and responsibility of the aircraft manufacturer, assembler or owner/user
- Due to the varying designs, equipment and types of aircraft, BRP-Rotax grants no warranty on the suitability of its engines use on any particular aircraft. Further, BRP-Rotax grants no warranty on this engines suitability with any other part, component or system which may be selected by the aircraft manufacturer, assembler or user for aircraft application

### **⚠ WARNING**

#### **Non-compliance can result in serious injuries or death!**

For each use of DAY VFR, NIGHT VFR or IFR in an aircraft the applicable legal requirements and other existing regulations must be adhered to.

- In addition to observing the instructions in our Manual, general safety and accident precautions, legal regulations and regulations of any aeronautical authority must be observed
- Where differences exist between this Manual and regulations provided by any authority, the more stringent regulation shall be applied
- For continued airworthiness see Maintenance Manual Line (MML)
- Unauthorized modifications of engine or aircraft will automatically exclude any liability of the engine manufacturer for consequential damage

# BRP-Rotax

## INSTALLATION MANUAL

- Engine operation**
- The engine must always be operated according to the content of the latest Operators Manual (OM)
  - To eliminate the risk of injury or damage, ensure any loose equipment or tools are properly secured before starting the engine
  - The use of propellers and their fastenings which exceed the specified values of moment of inertia and imbalance is not allowed and releases the engine manufacturer from any liability
  - Improper engine installation, use of unsuitable piping for fuel, cooling and lubrication system and use of unsuitable wiring for electric and engine management system releases the engine manufacturer from any liability

# BRP-Rotax INSTALLATION MANUAL

## INSTRUCTION

Engines require instructions regarding their installation, application, use, operation, maintenance and repair.

Technical documentation and regulations are useful and necessary complementary elements for trainings, but can by no means substitute for theoretical and practical instructions.

These instructions should cover explanation of the technical context, advice for operation, maintenance, installation, use and operational safety of the engine.

### Safety notice

In this technical Manual passages concerning safety are especially marked. Pass on safety warnings to other users!

### Accessories

This engine must only be operated with accessories supplied, recommended and released by BRP-Rotax. Modifications are only allowed after consent of the engine manufacturer.

### Spare parts



See Illustrated Parts Catalog (IPC), latest issue for the respective engine type.

#### NOTICE

**Only use GENUINE ROTAX® spare parts. Spare parts must meet the requirements defined by the engine manufacturer. This can only be guaranteed when using spare parts and/or accessories. Spare parts are available at Authorized Distributors and their independent Service Centers. Any warranty by will become void if spare parts and/ or accessories other than spare parts and/or accessories are used (see latest Warranty Conditions).**

See relevant Service Letter on [www.flyrotax.com](http://www.flyrotax.com).

### Standard tools / Special tools

#### NOTICE

**Only use tools and appliances which are suitable for the relevant task according to the latest Manuals.**

### State of delivery

#### ⚠ WARNING

**Engine and gearbox are delivered in “dry“ conditions (without fuel, oil and coolant).**

Before putting the engine into operation it must be filled with oil and cooling liquid. Use only oil and coolant as specified.



See latest Operators Manual (OM) and Service Instruction SI-916 i-001 “Selection of suitable operating fluids“, current issue.

# BRP-Rotax INSTALLATION MANUAL

## TECHNICAL DOCUMENTATION

These documents form the instructions ensuring continued airworthiness of ROTAX® aircraft engines.

The information contained herein is based on data and experience that are considered applicable for authorized mechanics (iRMT, see MML, Chapter 05–00–00 section “Authorized Personnel”) under normal conditions for engine removal and installation. Concerning design of engine installation in depth knowledge of aircraft design is required.

Due to the fast technical progress and fulfillment of particular specifications of the customers it may occur that existing laws, safety prescriptions, constructional and operational regulations may not be sufficient or cannot be transferred completely to the object bought, in particular for special constructions.

### Documentation

- Installation Manual (IM)
- Operators Manual (OM)
- Maintenance Manual Line (MML)
- Maintenance Manual Heavy (MMH)
- Overhaul Manual (OHM)
- Illustrated Parts Catalog (IPC)
- Alert Service Bulletin (ASB)
- Service Bulletin (SB)
- Service Instruction / Service Instruction-Parts and Accessories (SI-PAC)
- Service Letter (SL)



### Status

The status of the Manuals can be determined by checking the table of amendments. The first column of this table indicates the revision status, which should be compared with the revision provided on the ROTAX®-Website: [www.FLYROTAX.com](http://www.FLYROTAX.com)  
Amendments and current versions can be downloaded free of charge.

### Replacement pages

Furthermore the Manual is constructed in such a way that single pages can be replaced instead of the complete document. The list of affected pages is given in the chapter LEP. The particular edition and revision number is given on the footer of each page.

### Reference

This Manual is only part of the technical documentation and will be supplemented by the respective Operators Manual (OM), Maintenance Manuals and Illustrated Parts Catalog (IPC).

#### NOTICE

**Pay attention to references to other documentation, found in various parts of this Manual.**

If not stated otherwise, any reference to a document refers to the latest edition issued by BRP-Rotax.

# BRP-Rotax INSTALLATION MANUAL



This symbol informs you of additional references (data sheets, Manuals, etc.) associated with the given subject.

## Illustrations

The illustrations in this Manual are merely sketches and show typical arrangements. They may not represent full detail or the exact shape of the parts but should outline the same or similar function. Therefore deriving dimensions or other details from illustrations is not permitted.

TYPICAL indicates a general view which may not represent exact details.

## NOTE

*The Illustrations in this Manual are stored in a graphic database system and are provided with a consecutive, irrelevant, number.*

*This number (e.g. AE 5iS001) is of no significance for the content.*

Some measurements are given in the drawings, these are manufacturing dimensions and are subject to corresponding tolerances.

## Installation drawings

Installation drawings and a DMU-model for (virtual) installation analysis are available from the ROTAX® Authorized Distributors or their independent Service Centers on special request and relevant non disclosure and copyright regulations.

The illustrations in this Manual show a possible installation variant including non certified parts.



**BRP-Rotax**  
INSTALLATION MANUAL

**APPROVAL OF ELECTRIC AND ELECTRONIC COMPONENTS**  
**(EQUIPMENT QUALIFICATION ACCORDING TO RTCA/DO-160)**

RTCA/DO-160 defines a series of minimum standard environmental test conditions and applicable test procedures for airborne equipment. The purpose of these tests is to provide a laboratory means of determining the performance characteristics of airborne equipment in environmental conditions representative of those which may be encountered in airborne operation of the equipment.

Electric and Electronic components (incl. wiring harness, ECU, Fuse Box, PMA, Sensors and Actuators) of the 916 i A Series are considered as part of the equipment and have been tested and qualified according to the following table:

DO-160G, Section 4 — Temperature and Altitude	Cat. B3V <sup>1</sup>
DO-160G, Section 5— Temperature Variation	Cat. B
DO-160G, Section 6— Humidity	Cat. B
DO-160G, Section 7— Operational Shocks and Crash Safety	Cat. BD
DO-160G, Section 8 — Vibration	Cat. S (L)
DO-160G, Section 9 — Explosion Proofness	Test not performed
DO-160G, Section 10 — Water Proofness	Cat. S
DO-160G, Section 11 — Fluids Susceptibility	Cat. F
DO-160G, Section 12 — Sand and Dust	Cat. D
DO-160G, Section 13 — Fungus Resistance	Test not performed
DO-160G, Section 14 — Salt Spray	Cat. S
DO-160G, Section 15 — Magnetic Effect	Cat. A
DO-160G, Section 16 — Power Input	Cat. BXX
DO-160G, Section 17 — Voltage Spike	Cat. A
DO-160G, Section 18 — AF Cond. Susceptibility	Cat. Z
DO-160G, Section 19 — Induced Signal Susceptibility	Cat. ZCX
DO-160G, Section 20 — RF Susceptibility Conducted	Cat. M
DO-160G, Section 20 — RF Susceptibility Radiated	Cat. D
DO-160G, Section 21 — Emission RF Energy Conducted	Cat. B
DO-160G, Section 21 — Emission RF Energy Radiated	Cat. B
DO-160G, Section 22 — Lightning Induced Trans. Susceptibility	Cat. B3H3L3
DO-160G, Section 23 — Lightning Direct Effects	Test not performed

- 
1. Components were tested at „operating low temperature“ of - 40 °C (- 40° F) instead of - 45 °C (- 49 ° F).

# BRP-Rotax INSTALLATION MANUAL

DO-160G, Section 24 — Icing	Test not performed
DO-160G, Section 25 — Electrostatic Discharge	Cat. A

## Component surface tem- perature limits

System Limit	Min.	Max.
ECU	- 40 °C (- 40 °F)	80 °C (176 °F)
EGT Sensors (electronic box)	- 40 °C (- 40 °F)	80 °C (176 °F)
Fusebox	- 40 °C (- 40 °F)	80 °C (176 °F)
AC-DC Converter assy.	- 40 °C (- 40 °F)	80 °C (140 °F)

**BRP-Rotax**  
INSTALLATION MANUAL

**Chapter: 10-10-00**  
**STORAGE AND INSTALLATION**

**TOPICS IN THIS CHAPTER**

<b>Special tools</b> .....	<b>3</b>
<b>General</b> .....	<b>4</b>
Engine Storage .....	4
Unpacking the engine .....	5
Engine handling .....	9

**BRP-Rotax**  
**INSTALLATION MANUAL**

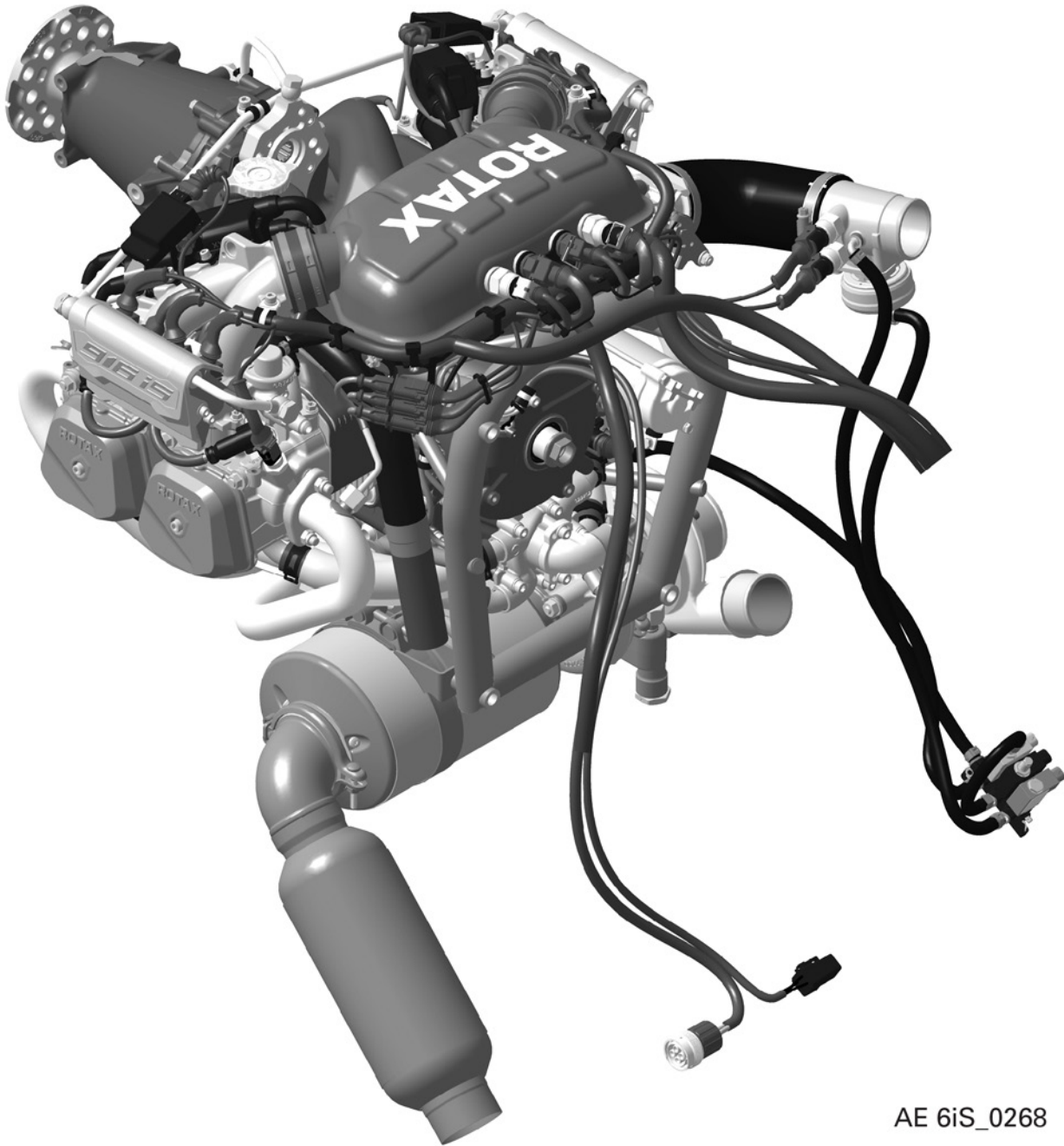

AE 6iS\_0268

Figure 2.1: 916 i A engine

**BRP-Rotax**  
INSTALLATION MANUAL

**SPECIAL TOOLS**

<b>Description</b>	<b>Part number</b>
Engine lift set	876040

# BRP-Rotax INSTALLATION MANUAL

## GENERAL

### NOTICE

**Risk of consequential damage to engine and aircraft as a result of corrosion and damage. Under no circumstances is a corroded or damaged engine to be installed in an aircraft!**

## ENGINE STORAGE

The engine is preserved at BRP-Rotax thus guaranteeing proper protection against corrosion damage for at least 12 months after the date of delivery from BRP-Rotax.

This warranty is subject to the following conditions:

- The engine must be stored in the GENUINE-ROTAX®-packing as supplied by BRP-Rotax.
- The covers on various openings must not be removed.
- The engine must be stored in a suitable place (at min. -40 °C/-40 °F and max. +80 °C/176 °F).
- The flat bag (blue) surrounding the engine must not be damaged or removed, as it protects the engine from corrosion and oxidation.

If the engine is stored for a period longer than 12 months (not stored in the GENUINE-ROTAX®-packing) then maintenance tasks must be carried out every 3 months as per the currently valid Maintenance Manual, section "Preservation of a new engine".

**General note** All general inspection, maintenance and repair has to be carried out in accordance with Advisory Circular AC 43.13 from FAA.

**Advisory Circular** This Manual "Advisory Circular" AC describes maintenance methods, techniques and practice. These are recognized and authorized for inspection and repairs in non-pressurized areas for which there are no separate maintenance and repair instructions.

**Corrosion** Environmental corrosion (on the external surfaces) is a naturally occurring process which can inevitably affect the continued airworthiness of the engine, engine mounted components and accessories. Susceptibility to corrosion is influenced by a number of factors, including but not limited to, geographical location, season and usage. All general preventive (technical) measures, identification, control and treatment of corrosive attack on aircraft structures and engine materials has to be carried out in accordance with Advisory Circular AC 43-4B from FAA and also in accordance with the information of the aircraft manufacturers Instruction for Continued Airworthiness. Furthermore the preservation procedures for stored and inactive aircraft (engines) provides an effective means for combating and minimizing the corrosion condition and should be adhered to.

Advisory Circular AC 43-4B This advisory circular (AC) is a summary of the current available data regarding identification and treatment of corrosive attack on aircraft structures and engine materials. Corrosion inspection frequency, corrosion identification, and especially corrosion treatment continues to be the responsibility of the operator. These inspections should be accomplished per this AC, the manufacturer's recommendations, or the operator's own maintenance program. The procedures in this AC are an acceptable

# BRP-Rotax INSTALLATION MANUAL

means, but not the only acceptable means, of corrosion treatment. The information in this AC is applicable to aircraft for which the manufacturer has not published corrosion control information.

## UNPACKING THE ENGINE

### NOTICE

**The attachment screws are only for transport and must not be used in the aircraft.**

### NOTICE

**During engine installation take into account the total engine weight and ensure careful handling.**

### Unpacking the engine

When the engine is delivered, check for damage of the packaging. If the package is damaged, contact a ROTAX® Authorized Distributor or their independent Service Center for ROTAX® aircraft engines.

To unpack a new engine and for checking the state of delivery, proceed as follows:

1. Remove the wooden cover.
2. Remove the bag and protective wrapping around the engine.
3. Check that the serial number and engine type on the type plate are identical to those shown on the delivery note.  
If the serial number or the engine type is deviating from the delivery contact a ROTAX® Authorized Distributor- or their independent Service Center for ROTAX® aircraft engines.
4. Check the engine for damage or corrosion.  
If the engine is damaged or corroded, contact a ROTAX® Authorized Distributor- or their independent Service Center for ROTAX® aircraft engines.
5. Screw off the transport bracket screws from wooden bottom of the box.
6. Remove transport brackets from engine.

### Protective coverings

### NOTICE

**Protective coverings are only for use during transport and engine installation. They must be removed completely (including sealing materials) before the engine is operated.**

All openings are protected against ingress of contamination and dampness. It is recommended to leave the protective plugs in place until installation of the specific feed line.

The protective coverings can be found at following locations:

**BRP-Rotax**  
INSTALLATION MANUAL

<b>Pos.</b>	<b>Installation location</b>	<b>Amount</b>
1	Muffler assy. with resonator assy.	
2	Fuel rail 2/4 outlet line / fuel pressure regulator	
3	Fuel rail 1/3 feed line	
4	Oil inlet/outlet and turbo return line to tank	
5	Coolant inlet/outlet	
6	Throttle body socket assy.	
7	Air intake socket on turbocharger	
8	Connection to / from intercooler	
9	Propeller shaft	
10	Intercooler	
11	Pressure Control Valve (PCV)	
12	Governor flange	



# BRP-Rotax INSTALLATION MANUAL

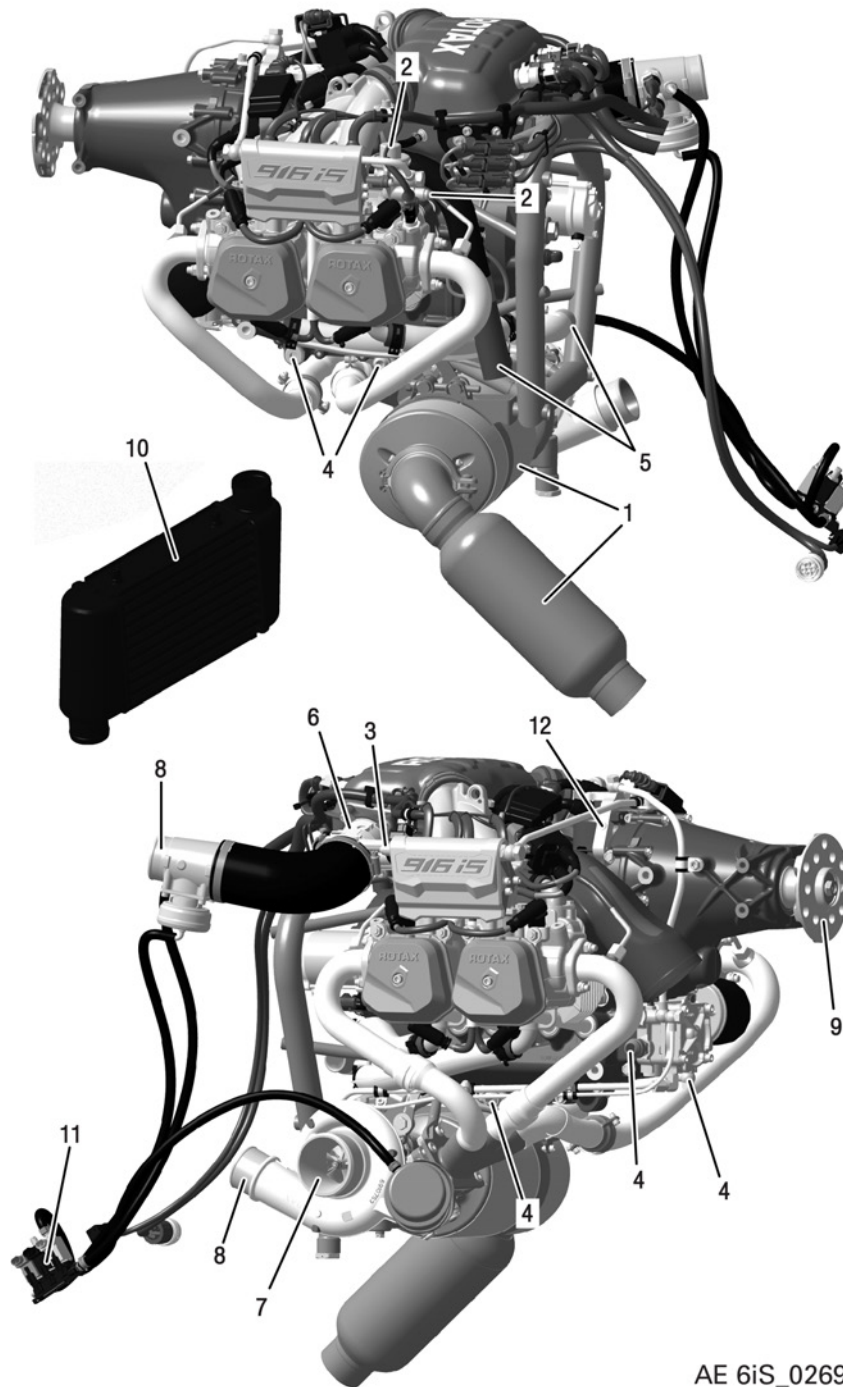

AE 6iS\_0269

Figure 2.2: Protective covering positions

- 1 Muffler assy. with resonator assy.      2 Fuel rail 2/4 outlet line / fuel pressure regulator

# BRP-Rotax

## INSTALLATION MANUAL

---

- |    |  |    |   |
|----|--|----|---|
| 3  | <i>Fuel rail 1/3 feed line</i>           | 4  | <i>Oil inlet/outlet and turbo return line to tank</i> |
| 5  | <i>Coolant inlet/outlet</i>              | 6  | <i>Throttle body socket assy.</i>                     |
| 7  | <i>Air intake socket on turbocharger</i> | 8  | <i>Connection to / from intercooler</i>               |
| 9  | <i>Propeller shaft</i>                   | 10 | <i>Intercooler</i>                                    |
| 11 | <i>Pressure Control Valve (PCV)</i>      | 12 | <i>Governor flange</i>                                |

# BRP-Rotax INSTALLATION MANUAL

## ENGINE HANDLING

### NOTICE

**Do not use the fuel lines or the wiring harness for lifting the engine!**

#### Attachment points

The engine may only be lifted on the dedicated attachment points by using the GENUINE-ROTAX®- engine lift set and a spreader bar with 350 mm (13.78 in) distance between lifting points. Make sure that lifting device does not bend the attachment lugs by relevant force distribution.

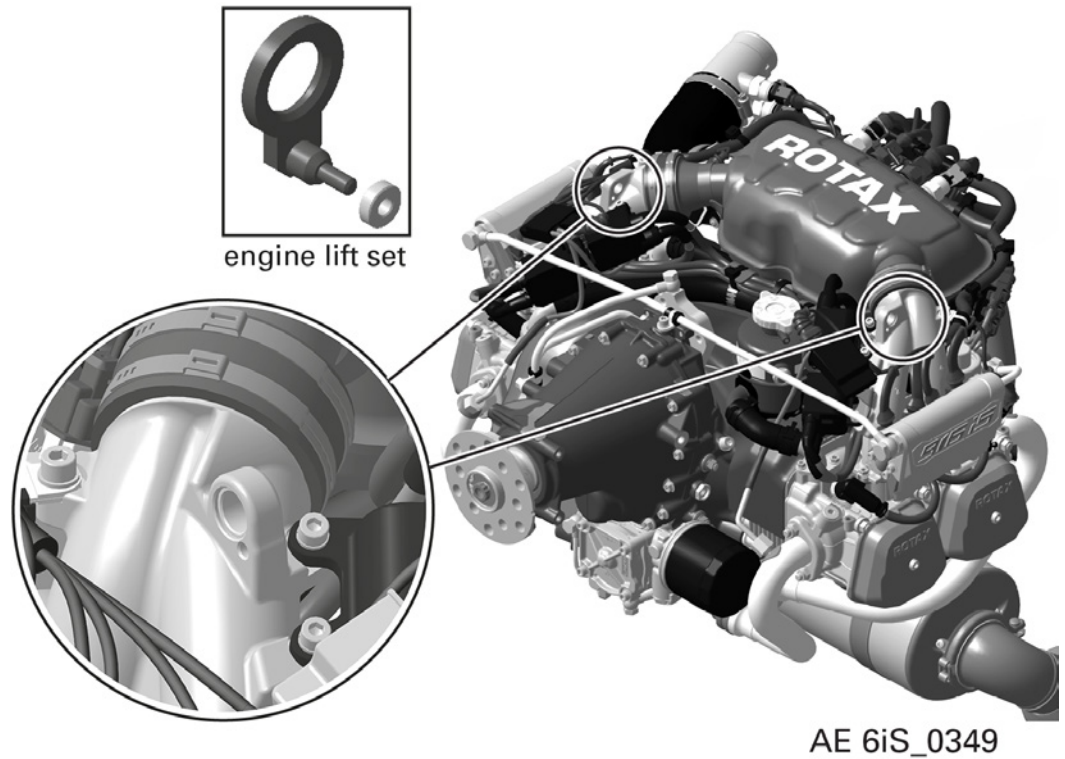

Figure 2.3: Attachment points

**BRP-Rotax**  
INSTALLATION MANUAL

INTENTIONALLY LEFT  
BLANK

**BRP-Rotax**  
INSTALLATION MANUAL

**Chapter: 24-00-00**  
**ELECTRICAL POWER**

**TOPICS IN THIS CHAPTER**

<b>System description</b> .....	<b>4</b>
System limitations .....	4
<b>Interface description– 916 I Type A</b> .....	<b>6</b>
Interface overview .....	6
Electrical interfaces .....	6
Mechanical interfaces .....	11
<b>Interface description – 916 I Type C24</b> .....	<b>12</b>
Interface overview.– 916 I Type C24 .....	12
Electrical interfaces – 916 I Type C24 .....	13
Mechanical interfaces – 916 I Type C24 .....	18
<b>Installation notes</b> .....	<b>20</b>
Installation overview .....	20
Grounding cables .....	20
Battery .....	21
Control elements .....	22
<b>Validation of installation</b> .....	<b>28</b>

# BRP-Rotax INSTALLATION MANUAL

916 i TYPE A

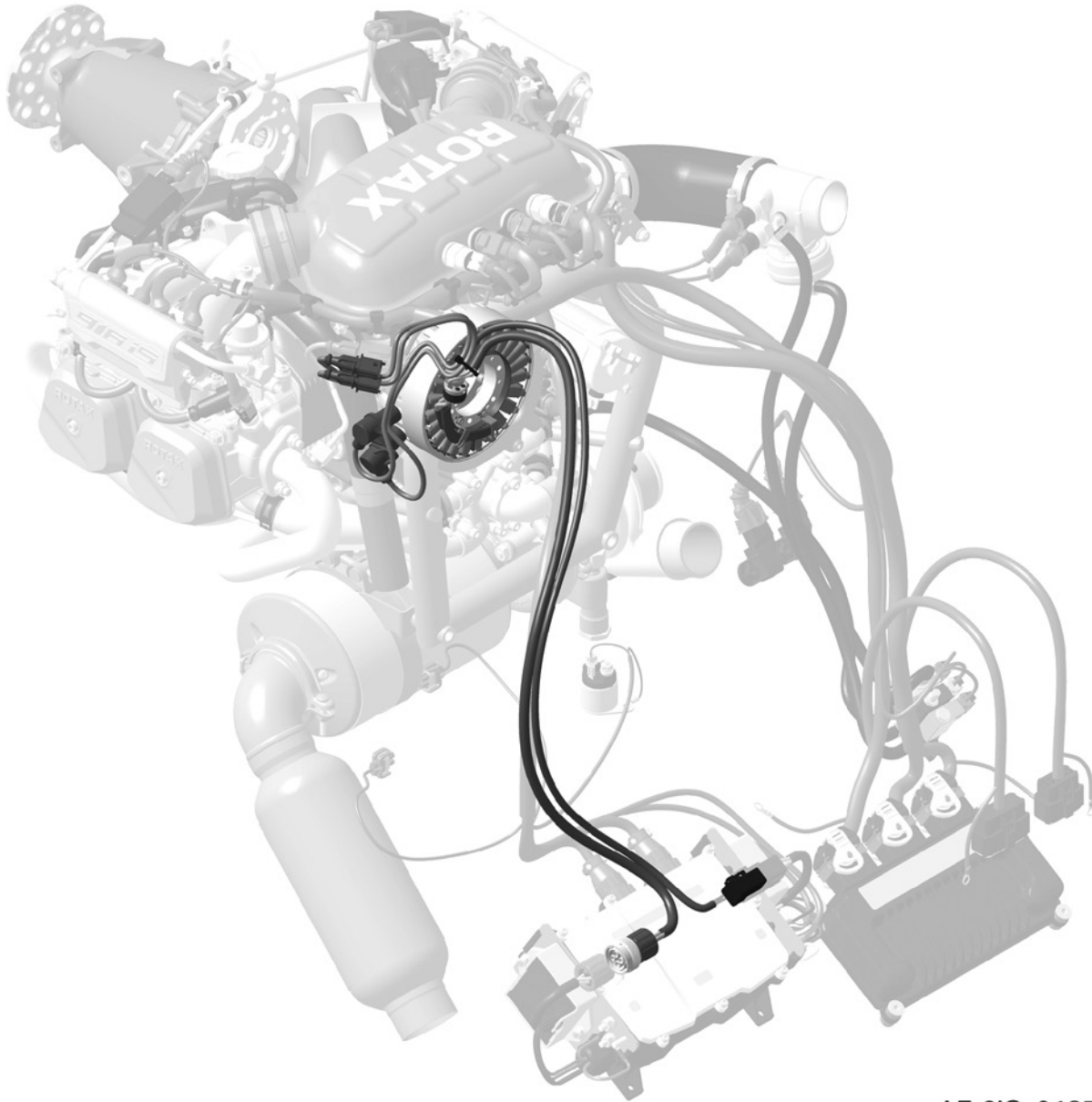

AE 6iS\_0185

Figure 3.1: Internal power supply

# BRP-Rotax INSTALLATION MANUAL

916 i TYPE C24

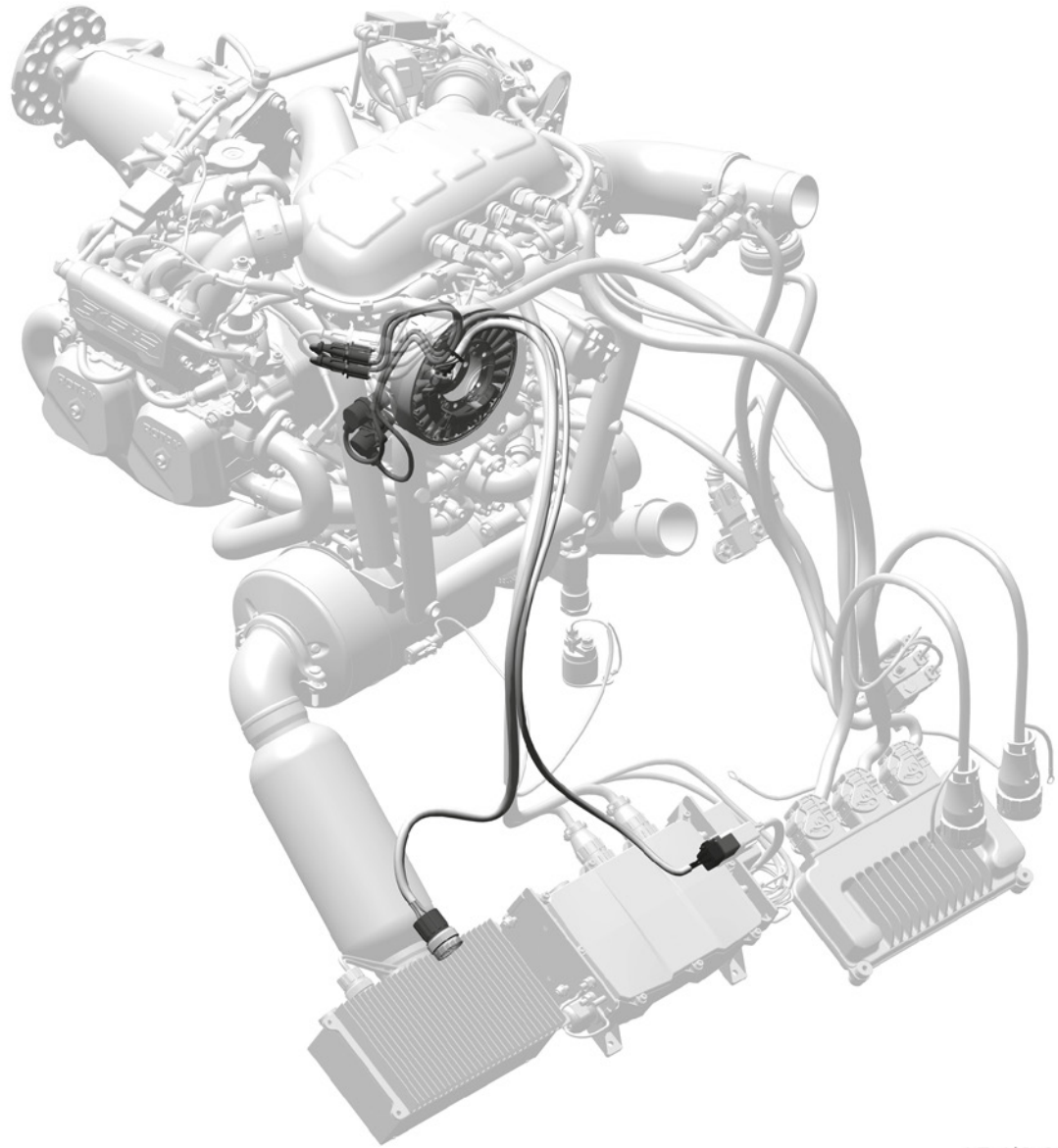

AE\_6iS\_0431

Figure 3.2: Internal power supply

# BRP-Rotax INSTALLATION MANUAL

## **SYSTEM DESCRIPTION**

For a detailed system description refer to the latest issue of the Operators Manual (OM).

## **SYSTEM LIMITATIONS**

### **NOTICE**

**Consumer cables must NOT be routed alongside the ignition cables. There is a risk of electromagnetic interference.**

#### **Valid installation positions**

The Fusebox must not be installed in the cockpit. Installation is only allowed in the engine compartment.

#### **Component temperatures limitation**

Limitations see Chapter 00-00-00 Approval of electric and electronic components.

The Regulator temperature must be measured as shown within the following figure:

#### **916 i TYPE A**

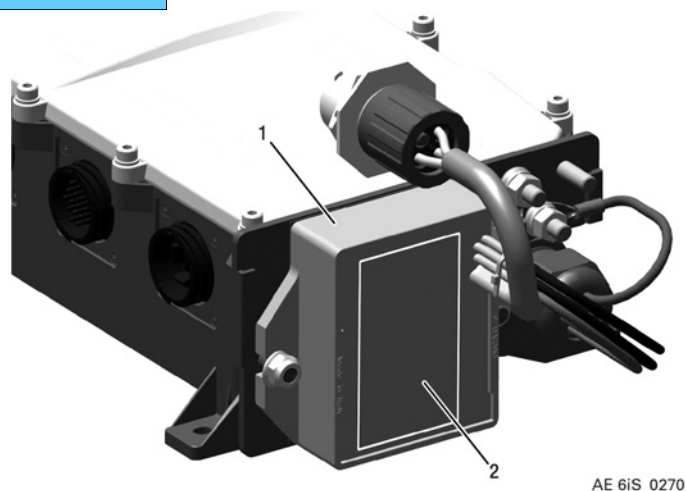

Figure 3.3: Regulator temperature measurement area

1 Rectifier regulator

2 Component temperature measurement area



# BRP-Rotax INSTALLATION MANUAL

916 i TYPE C 24

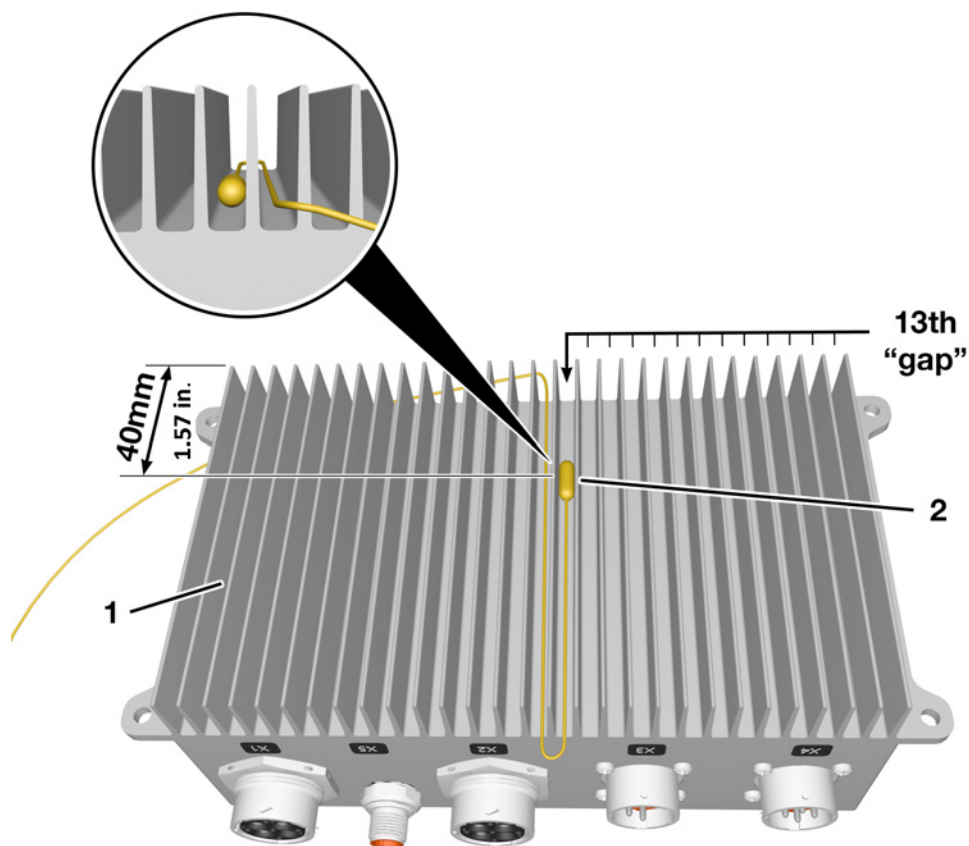

Figure 3.4: Regulator temperature measurement area

1 28 V AC-DC Converter assy.

2 Component temperature measurement area

## Separation of EMS and Airframe circuit

A connection between regulator plate A (EMS ground) and airframe ground should only be done during supply of the EMS System by an external power source (e.g. during engine start). Although it would have no impact on the redundancy of the EMS, the fault tolerance of the system will be degraded if the EMS ground is connected permanently with the airframe ground.

# BRP-Rotax INSTALLATION MANUAL

## INTERFACE DESCRIPTION– 916 I TYPE A

### INTERFACE OVERVIEW

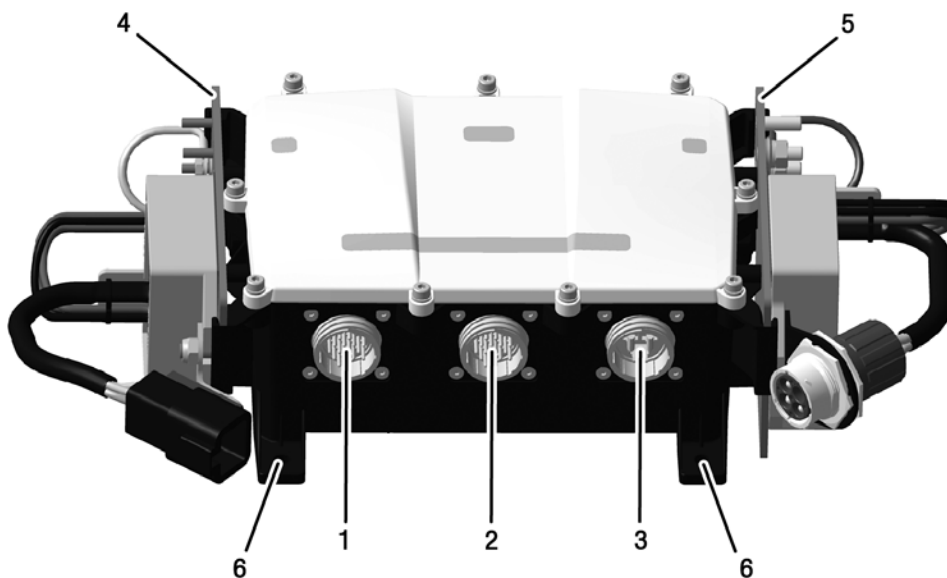

AE 6iS\_0113

Figure 3.5: Fusebox connections, TYPICAL

- |   |  |   |  |
|---|--|---|--|
| 1 | X1 Connector (electrical interface)      | 2 | X2 Connector (electrical interface)            |
| 3 | X3 Connector (electrical. interface)     | 4 | Regulator Plate A (electrical interface)       |
| 5 | Regulator Plate B (electrical interface) | 6 | Fusebox mounting points (mechanical interface) |

### ELECTRICAL INTERFACES

The seals supplied with the Fusebox must be inserted into the X1, X2 and X3 Connector (Fusebox side) to enable a good connection between plug and socket and thus avoid unnecessary vibrations and misalignment of connector pins.

#### **Fusebox –X1, X2 Connector**

The X1 and X2 ensure the power distribution to the EMS System. Both plugs must be connected with mating sockets on the (engine-) wiring harness. The connectors are not interchangeable and are marked on the wiring harness side.

#### **Fusebox–X3 Connector**

For information on the X3 Connector, see the relevant SI-PAC-012.

# BRP-Rotax INSTALLATION MANUAL

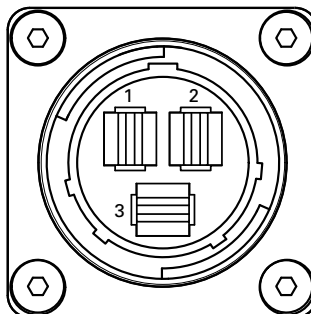

AE 5iS\_0372

Figure 3.6: X3-Connector: Fusebox side

- 1 Terminal 1
- 2 Terminal 2
- 3 Terminal 3

Terminal 1 enables to supply the EMS with an external power source (e.g. in case the internal power supply fails supplying the EMS). Terminal 2 enables powering the EMS during engine start (until the engine speed is high enough that the internal generator is able to supply the EMS). Terminal 3 can be used for supplying the Airframe with electrical energy after generator A has taken over powering the EMS.

Terminal	Interface Parameter	Min.	Max.	Nominal
1	Input voltage:	9 V <sup>2</sup>	14.5 V	12 V
	Input load:		230 W DC cont. 290 W DC peak	
2	Input: voltage:	9 V	14.5 V	12 V
	Input load:		230 W DC cont. 290 W DC peak	
3	Output voltage:	13.9 V	14.5 V	12 V
	Output capacity:		max. 420 W DC (at 20°) (68 °F) see section <a href="#">performance diagram</a>	

2. This limit must also be considered when the starter motor is actuated

# BRP-Rotax INSTALLATION MANUAL

## NOTICE

**In failure conditions the output voltage can exceed the specified limits.**

The following measurement is taken at an oil temperature of 135 °C (275 °F).

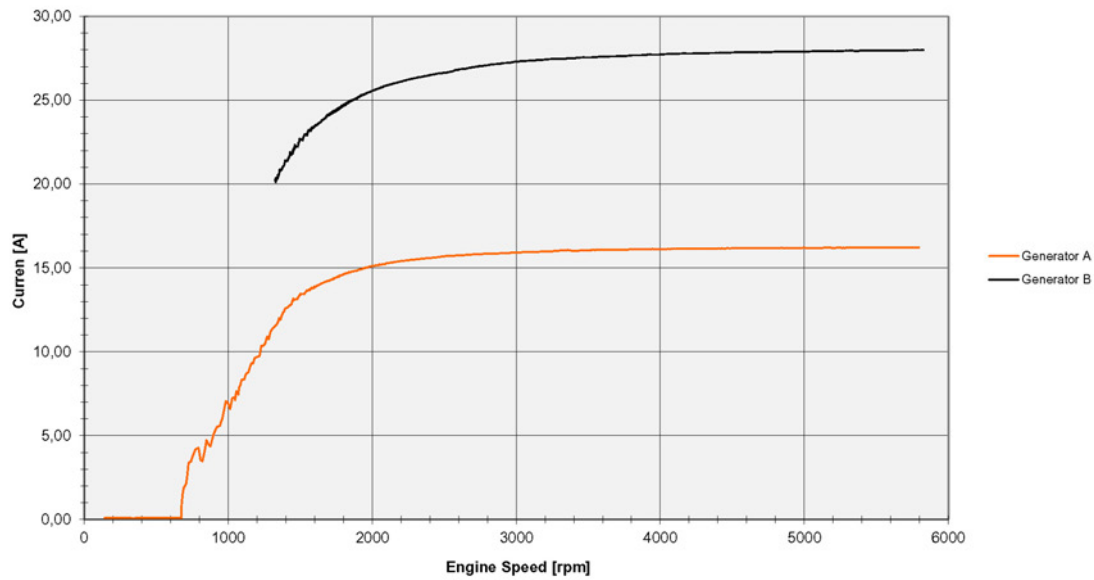

Figure 3.7: Characteristic curve of internal generators

# BRP-Rotax INSTALLATION MANUAL

## Fusebox Regulator A

The regulator plate A needs to be connected with the EMS Ground (cable lugs on the (engine-) wiring harness). The terminal is conducted as a M4 screw connection suitable for cable lug according to DIN 46225 (Tightening torque: 1.2 Nm (11 in. lb)). The cable lugs need to be evenly spread onto the three available terminals.

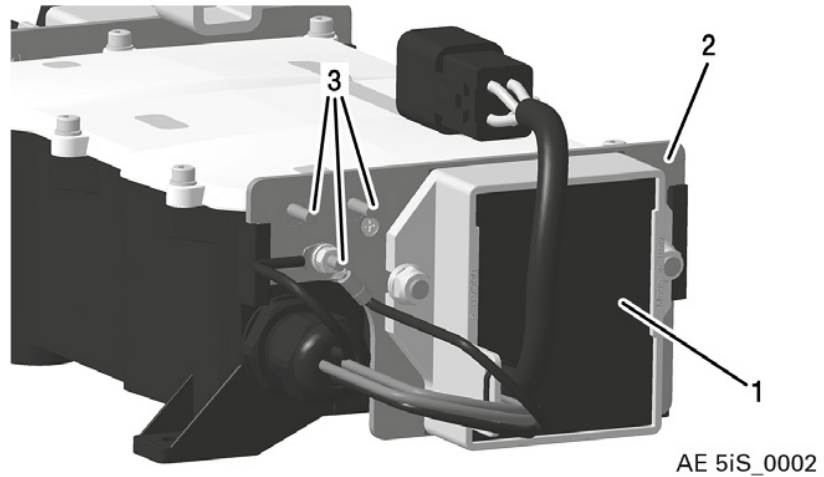

Figure 3.8: Fusebox -Regulator A

1 Regulator

2 Regulator plate A

3 Ground terminals

### NOTICE

A connection between regulator plate A and airframe ground should only be done during supply of the EMS System by an external power source (e.g. during engine start).

# BRP-Rotax INSTALLATION MANUAL

## Fusebox Regulator B

The Regulator B needs to be connected with the Airframe Ground. The terminal is conducted as a M6 screw connection suitable for cable lug according to DIN 46225 (Tightening torque: 5.9 Nm (52.5 in. in. lb)).

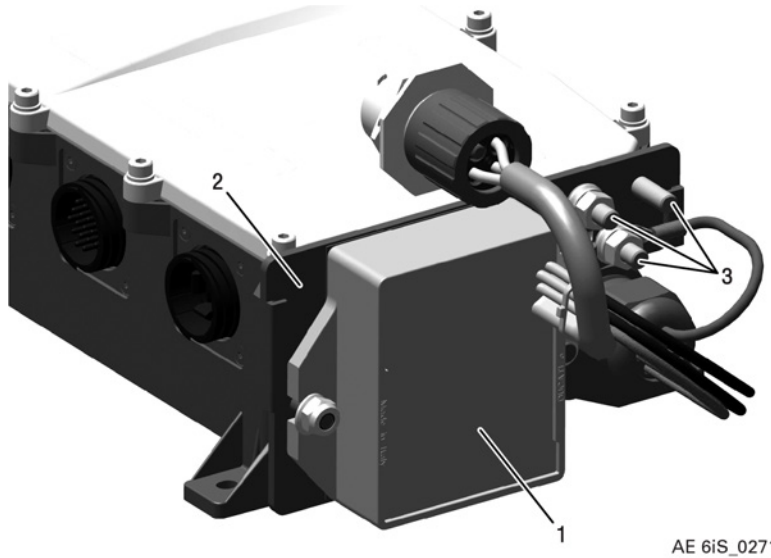

Figure 3.9: Fusebox -Regulator B

- 1 Regulator
- 2 Regulator plate B
- 3 Ground terminals

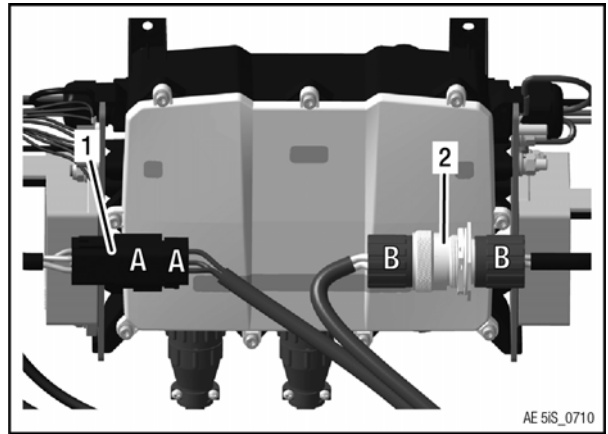

Figure 3.10: Fusebox

- 1 Connector Regulator A
- 2 Amphenol connector Regulator B

# BRP-Rotax INSTALLATION MANUAL

## MECHANICAL INTERFACES

### Fusebox mounting points

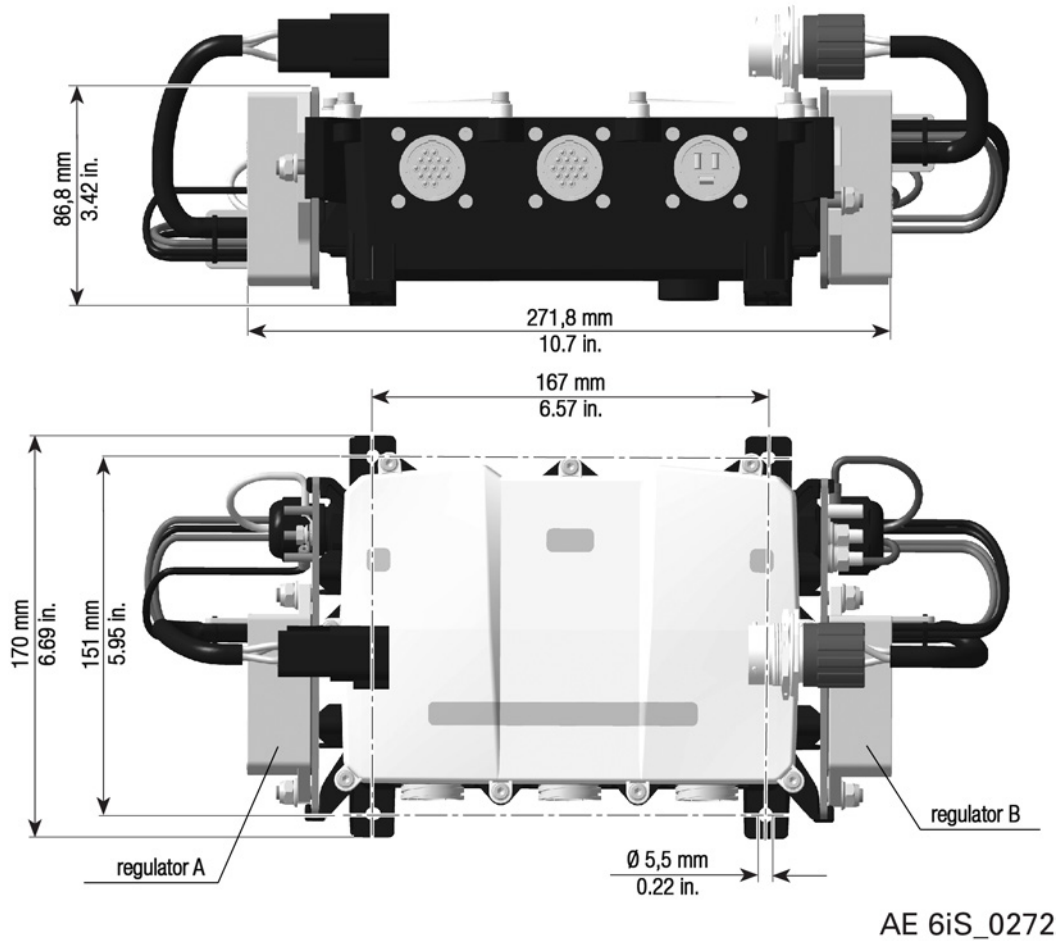

Figure 3.11: Fusebox –Connections and dimensions

## INTERFACE DESCRIPTION – 916 I TYPE C24

### INTERFACE OVERVIEW.– 916 I TYPE C24

916 i TYPE C 24

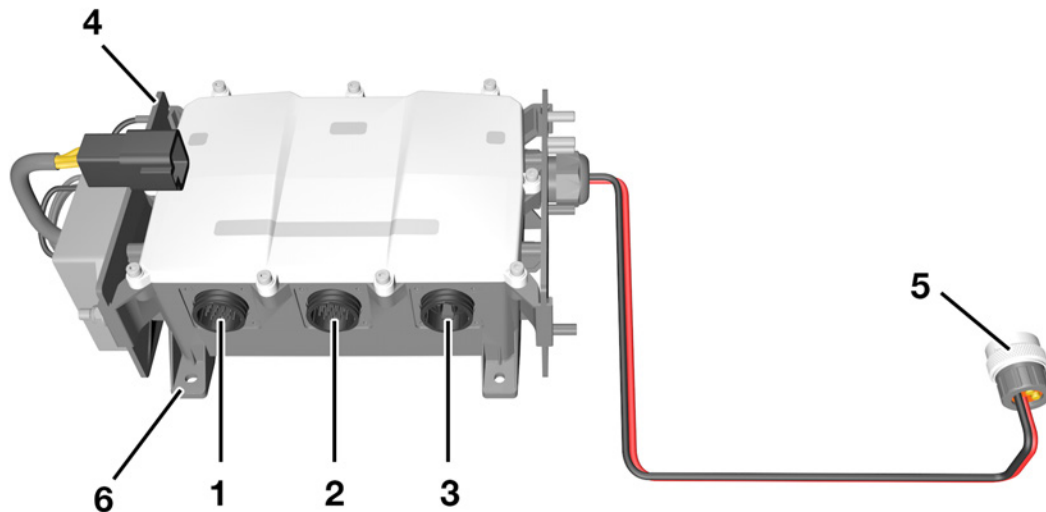

Figure 3.12: Fusebox connections

- |   |   |   |  |
|---|---|---|--|
| 1 | X1 Connector (electrical interface)     | 2 | X2 Connector (electrical interface)      |
| 3 | X3 Connector (electrical. interface)    | 4 | Regulator Plate A (electrical interface) |
| 5 | Connector to 28 V AC-DC Converter assy. | 6 | Mounting points                          |



# BRP-Rotax INSTALLATION MANUAL

## ELECTRICAL INTERFACES – 916 I TYPE C24

### 916 i TYPE C24

The seals supplied with the Fusebox must be inserted into the X1, X2 and X3 Connector (Fusebox side) to enable a good connection between plug and socket and thus avoid unnecessary vibrations and misalignment of connector pins.

#### Fusebox – X1, X2 Connector

The X1 and X2 ensure the power distribution to the EMS System. Both plugs must be connected with mating sockets on the (engine-) wiring harness. The connectors are not interchangeable and are marked on the wiring harness side.

#### Fusebox – X3 Connector

Terminal 1 enables the EMS to be supplied with an external power source (e.g. in case the internal power supply fails supplying the EMS).

Terminal	Interface Parameter	Min.	Max.	Nominal
1	Input voltage:			24 V
	Input load:		230 W DC cont. 290 W DC peak	
2	Plugged, do not pierce the plug seal.			
3	Plugged, do not pierce the plug seal.			

### NOTICE

**In failure conditions the output voltage can exceed the specified limits.**

# BRP-Rotax INSTALLATION MANUAL

## Fusebox Regulator A

The regulator plate A needs to be connected with the EMS Ground (ring terminals on the (engine-) wiring harness). The stud has M4 threads suitable for ring terminals according to DIN 46225 or MS25036-149 (size #8) (tightening torque: 1.2 Nm / 11 in lb). The ring terminals need to be evenly spread onto the three available studs.

916 i TYPE C24

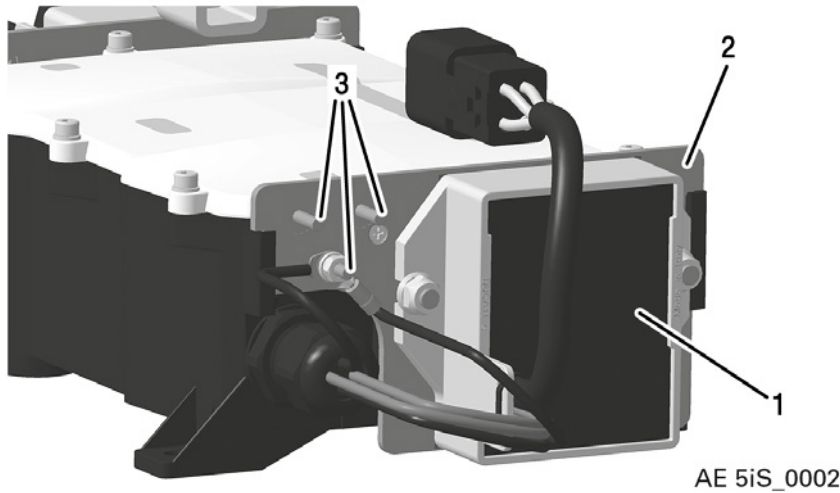

Figure 3.13: Fusebox -Regulator A

1 Regulator

2 Regulator plate A

3 Ground studs

### NOTICE

A connection between regulator plate A and airframe ground should only be done during supply of the EMS System by an external power source (e.g. during engine start).

# BRP-Rotax INSTALLATION MANUAL

## Fusebox

The Fusebox needs to be connected with the 28 V AC-DC Converter assembly.

916 i TYPE C24

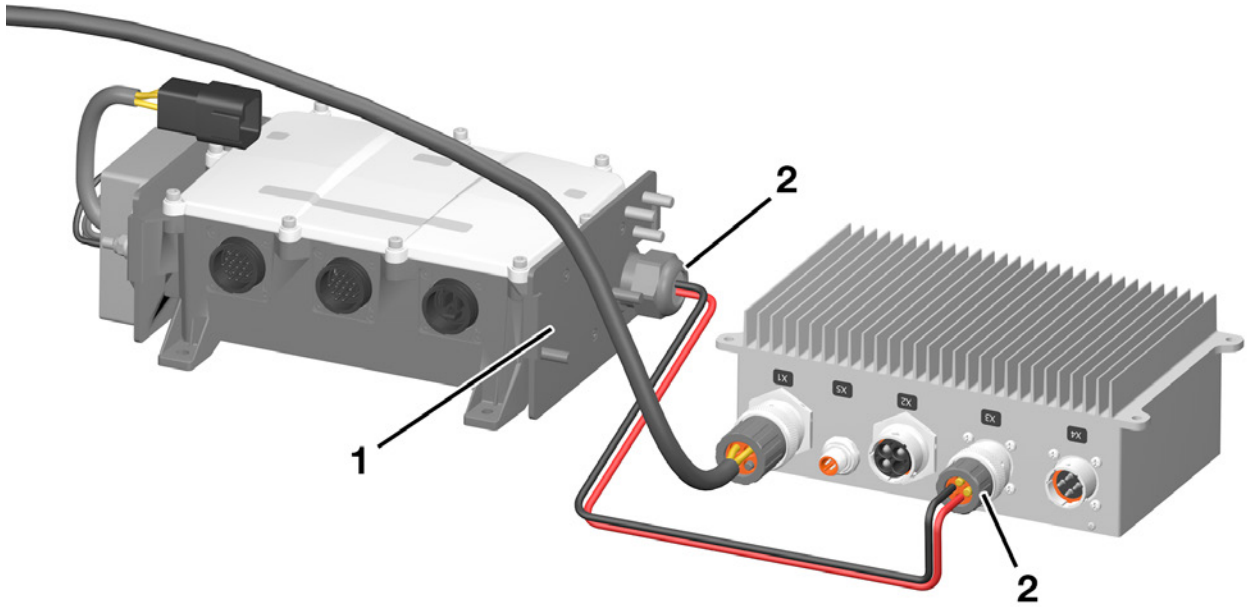

Figure 3.14

1 Fusebox

2 Connector to 28 V AC-DC Converter  
assy.

# BRP-Rotax INSTALLATION MANUAL

**28 V AC-DC CON-  
VERTER ASSY.**

916 i TYPE C24

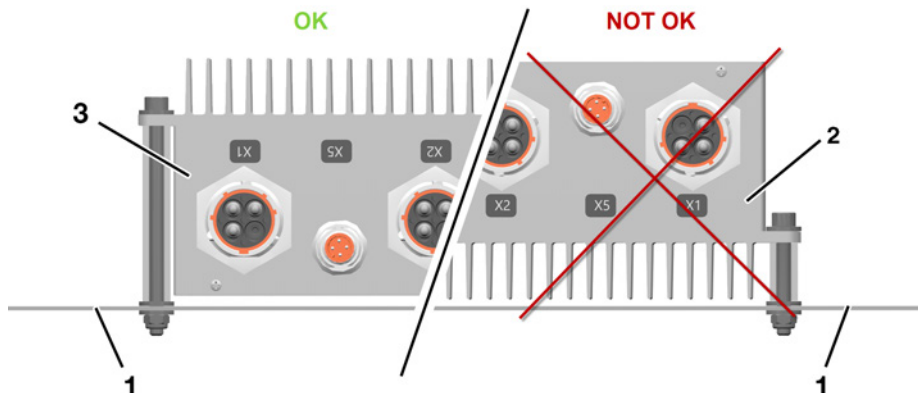

Figure 3.15: 28 V AC-DC Converter assy.

- |   |   |
|---|---|
| <p>1 Firewall</p> <p>3 Orientation of the heat sink to the firewall</p> | <p>2 Orientation of the heat sink NOT to the firewall</p> |
|---|---|

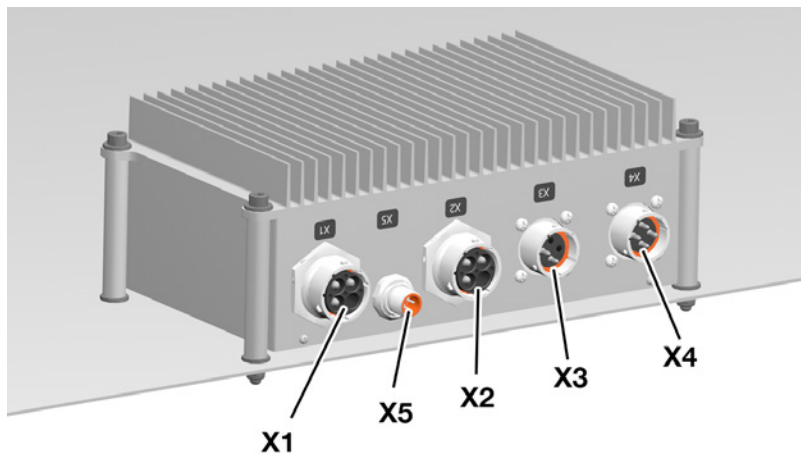

Figure 3.16: 28 V AC-DC Converter assy.

- |  |  |
|--|--|
| <p>X1 Generator B (stator cable from ignition housing)</p> <p>X3 Generator B (connector from Fusebox)</p> <p>X5 See Chapter 77-00-00</p> | <p>X2 Aircraft 28 V Bus / Battery 24 V</p> <p>X4 Cockpit Airframe side</p> |
|--|--|

## BRP-Rotax INSTALLATION MANUAL

**Generator B  
(stator cable  
from ignition  
housing)**

Connector	PIN	Function	Type
X1	A	Phase 1 of Generator	Input
	B	Phase 2 of Generator	Input
	C	Phase 3 of Generator	Input

**Aircraft 28 V  
Bus / Battery  
24 V**

Connector	PIN	Function	Type
X2	A	28 V (output for Aircraft)	Output
	B	28 V GND (output for Aircraft)	Output
	C	+24 V (Aircraft Battery Plus Pol)	Input

**Generator B (connector  
from  
Fusebox)**

Connector	PIN	Function	Type
X3	A	14 V (for EMS, connected at Fusebox B Minus Pol)	Output
	B	14 V GND (for EMS, connected at Fusebox B Minus Pol)	Output

**Cockpit Air-  
frame side**

Connector	PIN	Function	Type
X4	A	14 V (for EMS, Battery Backup)	Output
	B	14 V GND (for EMS, Battery Backup)	Output
	C	14 V (for Fuel Pump 2 / Aux.)	Output
	D	14 V GND (for Fuel Pump 2 / Aux)	Output
X5		See Chapter 77-00-00.	

# BRP-Rotax INSTALLATION MANUAL

## MECHANICAL INTERFACES – 916 I TYPE C24

Fusebox and  
Converter assy.  
mounting points

916 i TYPE C 24

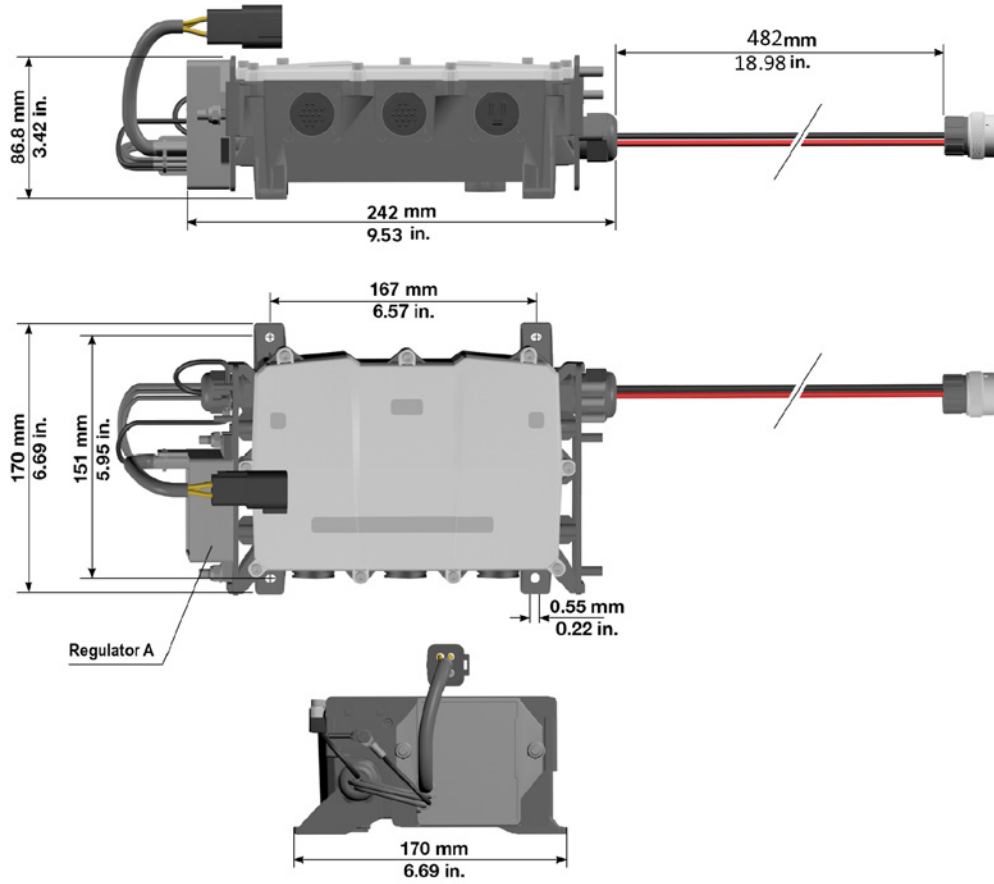

AE\_5iS\_0826

Figure 3.17: Fusebox –Connections and dimensions

**BRP-Rotax**  
**INSTALLATION MANUAL**

916 i TYPE C 24

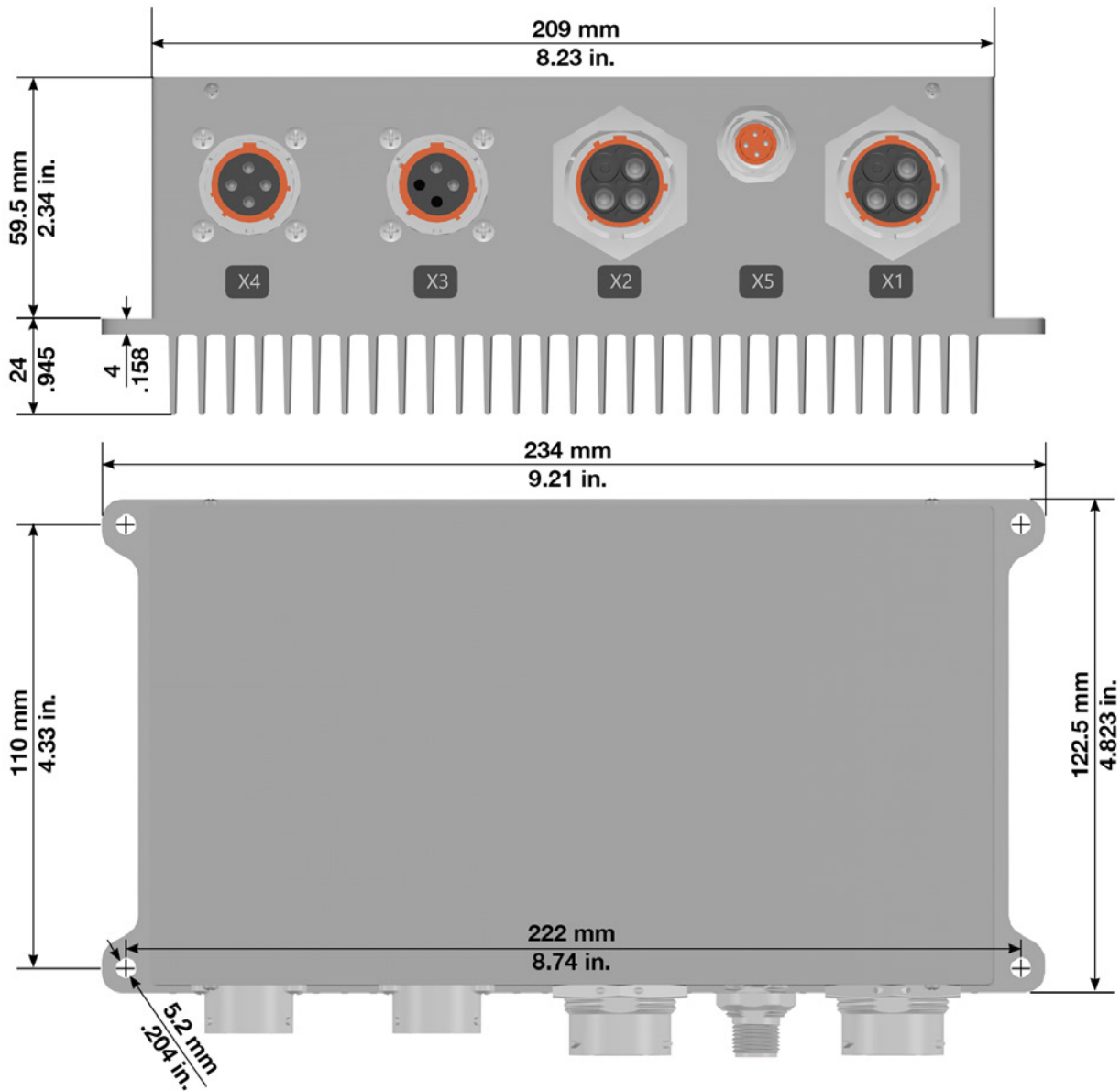

Figure 3.18: 28 V Converter: Connections and dimensions

**NOTE**

*28 V AC-DC converter need to be installed with connector facing down.*

# BRP-Rotax INSTALLATION MANUAL

## INSTALLATION NOTES

### General

The representation of components in this chapter which are not within scope of the delivery is only symbolic. The design shown in this chapter does not represent a specified execution but should support the understanding of the system.

The final design, the selection and specification of parts according to the respective applicable regulations, the consideration of the system limitations and interface description as well as the comprehension of the operating limits in every operational state is in the responsibility of the aircraft manufacturer.

The aircraft manufacturer has to make sure that the operating limits given in the Operators Manual (OM) can be supervised by the pilot. The execution of the installation must allow the operation of the engine according to the Operators Manual (OM).

## INSTALLATION OVERVIEW

### Wiring diagram NOTE

*For improved clarity, see diagrams in Chapter 92-00-00 "Wiring diagrams".*

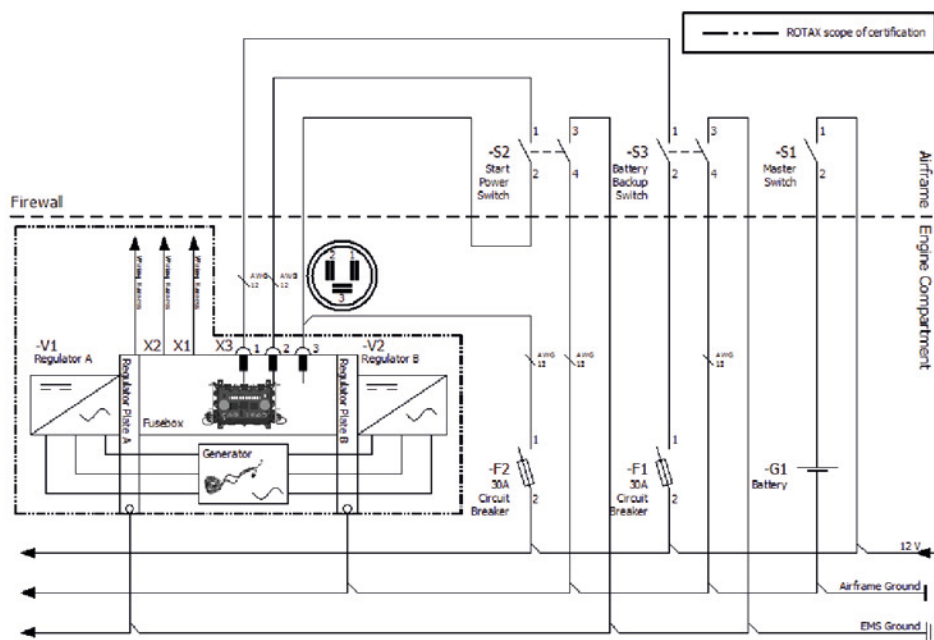

AE 5iS\_0160

Figure 3.19: Wiring diagram

## GROUNDING CABLES

The wiring of the grounding cables is an essential point when conducting engine electronics. Following two circuits must be distinguished:

- Airframe circuit
- Engine management system circuit (EMS circuit)



# BRP-Rotax INSTALLATION MANUAL

During engine start (dynamic condition, transient), the two circuits are connected to each other.

When the engine is running or when the engine is turned off ( and the Fusebox is not supplied with external power), the EMS circuit is electrically isolated from the rest of the aircraft.

Therefore, the following components need to be installed without any contact to the air-frame ground:

- ECU
- Regulator A (mounted on Fusebox)

The engine block must be connected to the airframe using a properly sized ground strap (minimum the same cable cross section as the starter supply but at least 10 mm<sup>2</sup>), for carrying the starter current and to avoid static electricity between the engine and the airframe.

To gain full lightning strike compliance the rubber shock mounts must be bridged by using ground straps (min. 10 mm<sup>2</sup>).

## BATTERY

### NOTICE

**The use of rechargeable batteries with lithium-ion technology should only be used in combination with a suitable battery management system. If such a battery is used, the responsibility is up to the aircraft manufacturer. The approval of the relevant aeronautical authority may be necessary. For installation of lithium-ion batteries refer e.g. to FAA AC No: 20-184**

The specification of the battery must ensure that during each operating state and also during the transition between two operation states a sufficient supply of the avionics is guaranteed (e.g. during engine start). Depending on the applicable regulations avionics need to be supplied for at least 30 minutes with energy after a failure of the primary power supply in case they are required for safe operation of the aircraft.

If the aircraft is regularly started at temperatures below - 5 °C (23 °F) (ambient- and oil/coolant temperature are below this temperature) it is recommended to provide a connection for an external power supply and a possibility for adequate engine pre-heating.

### NOTICE

If all consumers are active, take care not to discharge the battery deeply.

Following battery specifications are recommended:

**916 i TYPE A**

## BRP-Rotax INSTALLATION MANUAL

Interface Parameter	Min.	Max.	916 i Type A Nominal
Nominal Input Voltage			12 V
Internal resistance		Maximum 10 mΩ at -18 °C (-0.4 °F)	
Cold Cranking Ampere	350 A at -18 °C (-0.4 °F) (SAE J537)		
Capacity	16 Ah		

Following battery specifications are recommended:

### 916 i TYPE C24

Interface Parameter	Min.	Max.	916 i Type C24 Nominal
Nominal Input Voltage			24 V
Internal resistance		Maximum 40 mΩ at -18 °C (-0.4 °F)	
Cold Cranking Ampere	175 A at -18 °C (-0.4 °F) (SAE J537)		
Capacity	8 Ah		

The usage of a battery with lower capacity may have a negative impact on the starting behavior of the engine. Additional electrical loads, which are in some cases required by law, may affect the battery performance during the starting process, (e.g. ACL (Anti Collision Light), Navigation Light, Avionics).

## CONTROL ELEMENTS

### 916 i TYPE A

START POWER CONTROL	
Parameter	Value
Contact type	Momentary (must not be active after engine start)
Nominal voltage	28 V DC
Nominal current	20 A

## BRP-Rotax INSTALLATION MANUAL

<b>BATTERY BACKUP CONTROL</b>	
Parameter	Value
Contact type	Toggle (must not be active during normal operation)
Nominal voltage	28 V DC
Nominal current	20 A

### 916 i TYPE C24

<b>START POWER CONTROL</b>	
Parameter	Value
Contact type	Momentary (must not be active after engine start)
Nominal voltage	24 V DC
Nominal current	20 A

<b>BATTERY BACKUP CONTROL</b>	
Parameter	Value
Contact type	Toggle (must not be active during normal operation)
Nominal voltage	24 V DC
Nominal current	20 A

### 916 i TYPE C24

The 28 V output of the AC-DC Converter is able to supply a maximum current of 27.9 A. If this current flow is exceeded, the 28 V output is switched off because an overload has been detected. The so-called hiccup mode now performs a cyclic activation of the output and queries the elimination of the overload. This is done in intervals of about three seconds.

If an accumulator is connected to the 28 V output and its charge state is very low, it can happen that the charge current exceeds the 27.9 A mentioned above. A switch-off of the 28 V output is the consequence and an overload is permanently detected by the hiccup mode. Charging the accumulator is therefore not possible.

# BRP-Rotax INSTALLATION MANUAL

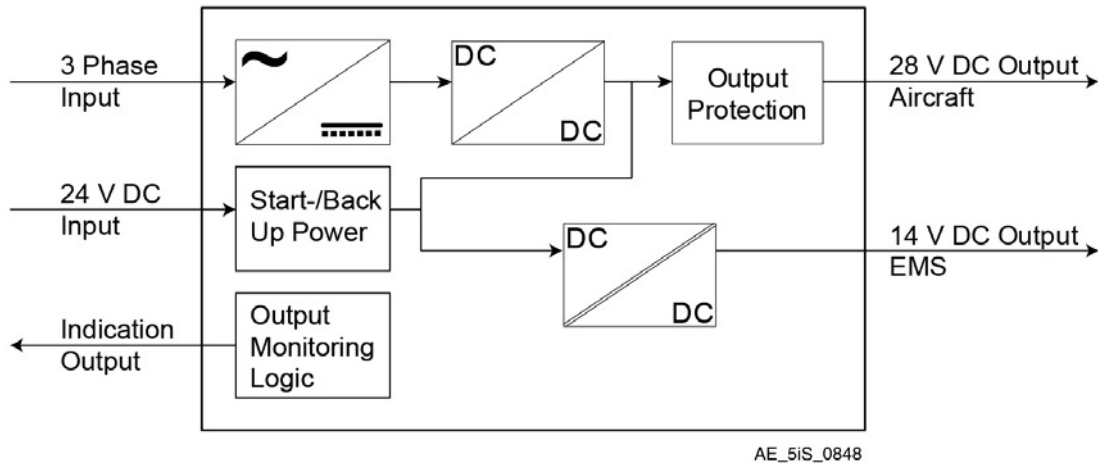

Figure 3.20: Schematic AC-DC Converter

**Concept for limiting the charging current:**

In order to limit the charging current, a series resistor can be used. In following Figure this resistor is called  $R_I$ .  $R_{L1}$  and  $R_{L2}$  are symbolically shown as load ( $L = \text{Load}$ ) of the 28 V output and define the current flow  $I_{\text{Load}}$ .

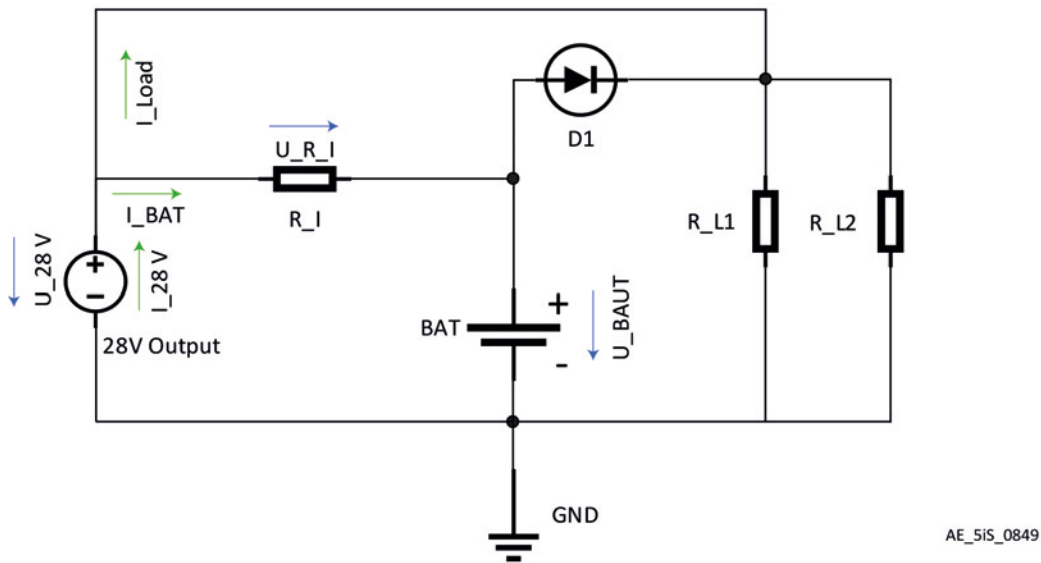

Figure 3.21: Simple Charging Circuit

# BRP-Rotax

## INSTALLATION MANUAL

### Formula 1

The voltage drop  $U_{R_I}$  is the difference of  $U_{28 V}$  and  $U_{BAT}$ :

$$U_{R_I} = U_{28 V} - U_{BAT}$$

### Formula 2

The current flow  $I_{BAT}$  can be calculated as follows:

$$I_{BAT} = \frac{U_{R_I}}{R_I}$$

#### Example 1 – Calculate series resistance

$U_{28 V} = 28.9 V$ ,  $U_{BAT} = 20 V$ ,  $I_{BAT} = 10 A$

The accumulator is discharged, and the State of Charge is 0%. For  $U_{BAT}$  in this case 20 V is assumed. The AC-DC converter supplies a voltage of 28.9 V. The maximum charge current is set to 10 A.  $U_{R_I}$  is therefore 8.9 V.

Formula 2 is transformed to  $R_I$  and from the division  $U_{R_I}$  to  $I_{BAT}$  a resistance value of 0.89  $\Omega$  results.

The following figures show the relationship between resistance  $R_I$  and current  $I_{BAT}$  and the resulting power dissipation once for  $U_{R_I} = 9 V$  and  $U_{R_I} = 5 V$ .

# BRP-Rotax INSTALLATION MANUAL

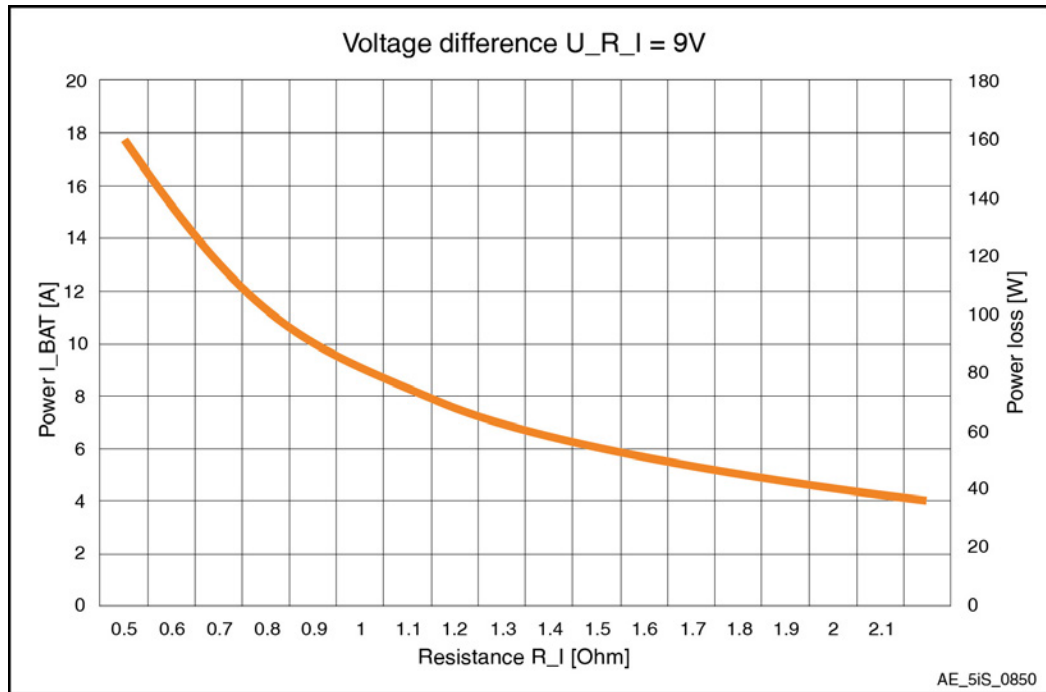

Figure 3.22:  $U_{R_I} = 9V$

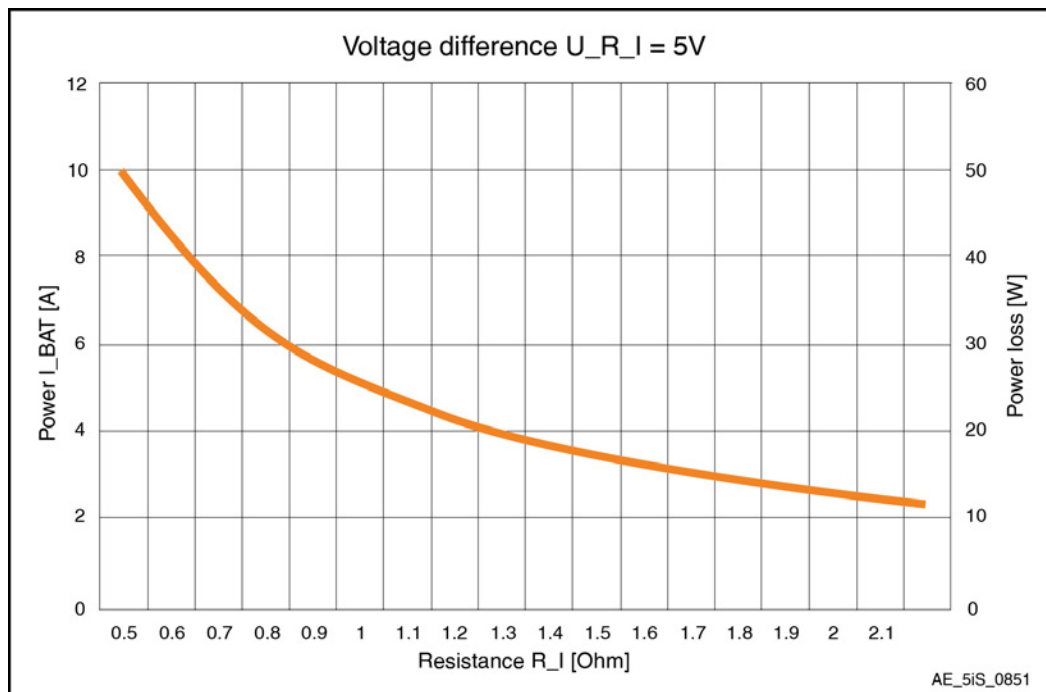

Figure 3.23:  $U_{R_I} = 5V$

# BRP-Rotax

## INSTALLATION MANUAL

### Formula 3

The sum of the currents from I\_BAT and I\_Load results in I\_28 V and must not exceed 27.9 A:

$$I_{\text{BAT}} + I_{\text{Lad}} < 27.9 \text{ A}$$

### Formula 4

$$I_{\text{BAT}} + I_{\text{Load}} = I_{\text{28 V}}$$

If I\_28 V is greater than 27.9 A, the 28 V output is switched off, as already mentioned at the beginning. Therefore, the condition from formula 3 must always be fulfilled. The expected load current I\_BAT and the load current I\_Load must be calculated by the installer.

### Formula 5

Special attention must be paid to the dimensioning of the resistor with regard to the power dissipation:

$$P = I_2 \cdot R$$

Once the battery is charged, the current flow is reduced to a minimum and thus also the power loss, which is converted into heat.

#### Example 2 – Calculate power dissipation:

$I = 10 \text{ A}$ ,  $R_I = 0.89 \Omega$

From formula 5, the worst-case power dissipation is 89 Watts.

To supply the aircraft with voltage when the AC-DC converter is not active, the accumulator is used. Therefore, it must also be connected to the loads R\_L1 and R\_L2. Without the diode D1, the resistor R\_I would be bypassed, and a current limitation would no longer exist. The choice and dimensioning of the diode must be adapted to the individual requirements of the aircraft. Parameters like voltage drop, current and cooling must be considered.

#### Summary:

By using a series resistor R\_I the charging current to the accumulator can be limited.

Feeding the aircraft via the accumulator gate is made possible by a diode which prevents bridging of the series resistor R\_I.

Special attention must be paid to the component dimensioning in order to achieve the desired reliability at these relatively high currents.

# BRP-Rotax INSTALLATION MANUAL

## VALIDATION OF INSTALLATION

### General

The validation procedures described in this chapter do not claim to be complete. The correct execution and compliance with all given system limitations and interface descriptions as well as with standards and norms given by authorities must be proven by the aircraft manufacturer.

### External Power Supply

If an engine is installed in a specific aircraft type for the first time, it is required to measure the voltage on three positions:

- Battery Voltage (separate Voltmeter)
- Voltage on Electric Starter (separate Voltmeter)
- ECU Bus Voltage (displayed in BUDS Aircraft diagnostic tool)

Depending on the location where the engine should be used, this measurement must be done at the lowest reachable temperature. In case the measured voltages drop below 9 V especially during engine start, the installation is insufficient. In this case specification of the external power source the execution of the wiring as well as the total consumption of all electrical loads needs to be checked.

### Separation of EMS and Airframe circuit

Proof the continuity between Fusebox Regulator A and Fusebox Regulator B in static condition (Fusebox is not supplied with power by an external power source). To determine the ECU BUS voltage at the transient moment of the engine start a oscilloscope must be used as well as the total consumption of all electrical loads needs to be checked.

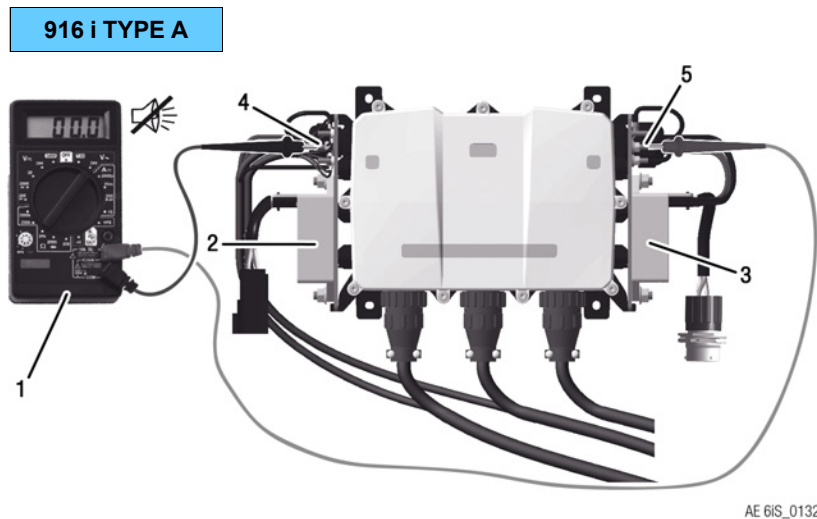

Figure 3.24: Validation of EMS and Airframe Circuit separation

- |   |                                  |   |                               |
|---|----------------------------------|---|-------------------------------|
| 1 | Multimeter                       | 2 | Regulator A (black connector) |
| 3 | Regulator B (Amphenol connector) | 4 | Ground connectors regulator A |
| 5 | Ground connectors regulator B    |   |                               |

In case of continuity the installation is not sufficient and the wiring concept needs to be revised.



# BRP-Rotax INSTALLATION MANUAL

## Separation of EMS and Air- frame circuit

### 916 i TYPE C24

Test to ensure there is no continuity between Fusebox Regulator A and Fusebox Regulator B in static condition (Fusebox is not supplied with power by an external power source). To determine the ECU BUS voltage at the transient moment of the engine start an oscilloscope must be used and also the total consumption of all electrical loads needs to be checked.

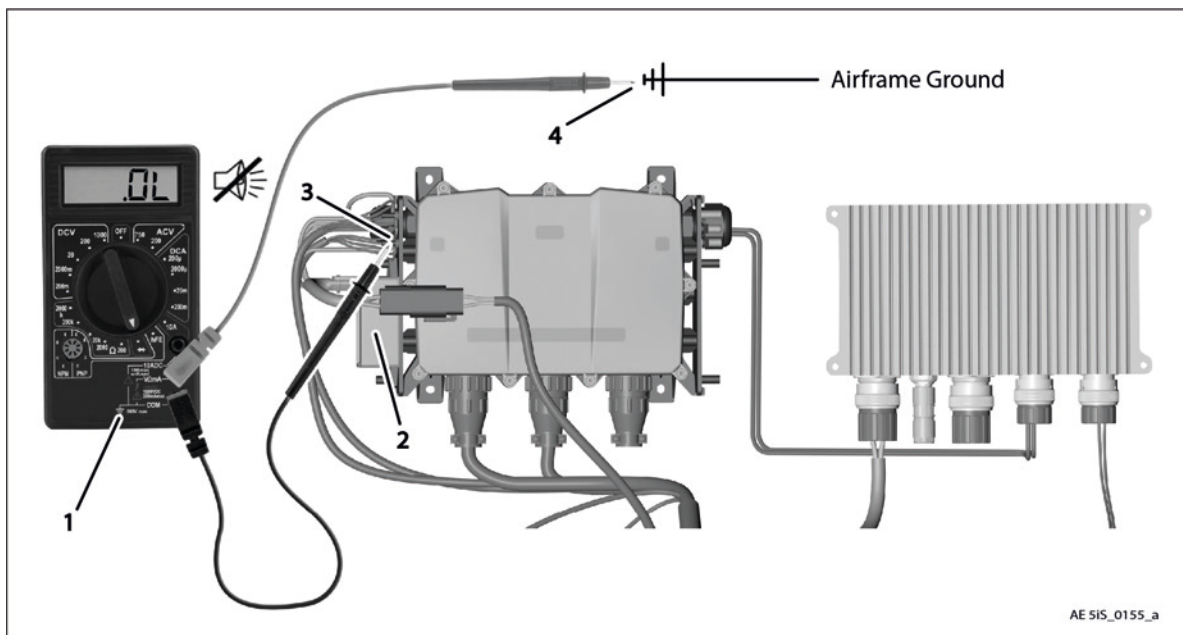

Figure 3.25: Validation of EMS and Airframe Circuit separation

- |   |                                |   |   |
|---|--------------------------------|---|---|
| 1 | Multimeter                     | 2 | Rectifier regulator A (black connector) |
| 3 | Ground connections regulator A | 4 | Airframe ground                         |

In case of continuity the installation is not sufficient and the wiring concept needs to be revised.

# BRP-Rotax INSTALLATION MANUAL

## EMS and Air- frame circuit test for AC-DC Converter

### 916 i TYPE C24

Test to ensure there is no warning or caution lamp indication between AC-DC Converter and any known airframe (aircraft) ground when EMS system is powered (EMS system is powered on, engine need to run for this test - please follow the procedures mentioned in the current Operators Manual. The engine must run on an engine speed at 3000 1/min for at least 2 minutes.)

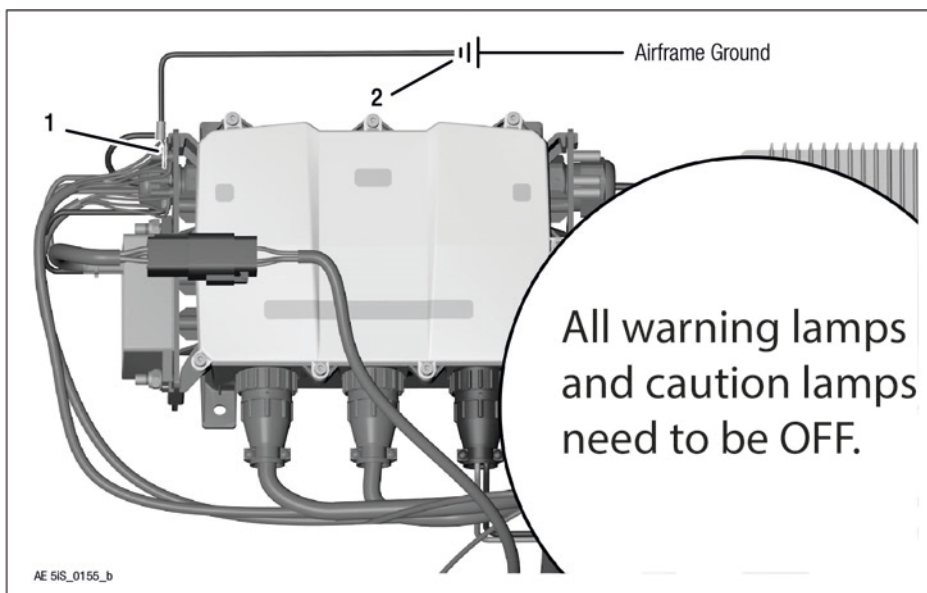

Figure 3.26: Airframe circuit test for AC-DC Converter

1 Ground connections regulator A      2 Airframe ground

- Connect a cable between ground connections regulator A to any airframe ground point
- Check all safety regulations, because EMS system now gets powered ON and the engine will be started
- Run the engine for 2 minutes at 3000 1/min (follow the procedures mentioned in the current Operators Manual).

## Check for warning and/ or caution lamp indication

### 916 i TYPE C24

Check that warning lamps and caution lamps stay OFF at an engine speed of 3000 1/min and for 2 minutes engine run. If not, there is a connection between EMS ground and airframe ground which need to be detected and removed before engine and aircraft can be released.

**BRP-Rotax**  
INSTALLATION MANUAL

**Chapter: 61-00-00**  
**PROPELLER DRIVE**

**TOPICS IN THIS CHAPTER**

**System description** .....3  
    System limitations .....3

**Interface description** .....4  
    Interface overview .....4  
    Mechanical interfaces .....6  
    Hydraulic governor for constant speed propeller .....8

**BRP-Rotax**  
INSTALLATION MANUAL

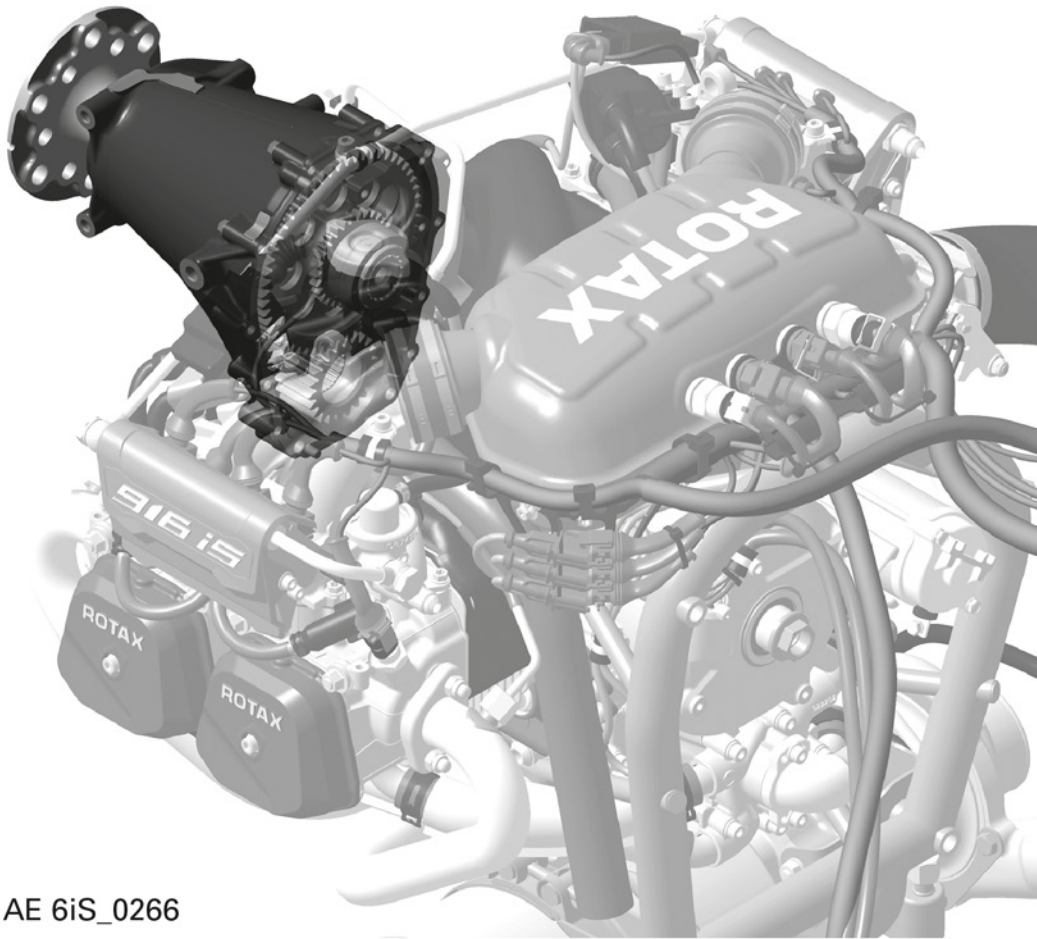

AE 6iS\_0266

Figure 4.1: Propeller drive



**BRP-Rotax**  
INSTALLATION MANUAL

**INTERFACE DESCRIPTION**

**INTERFACE OVERVIEW**

AE 6iS\_0274

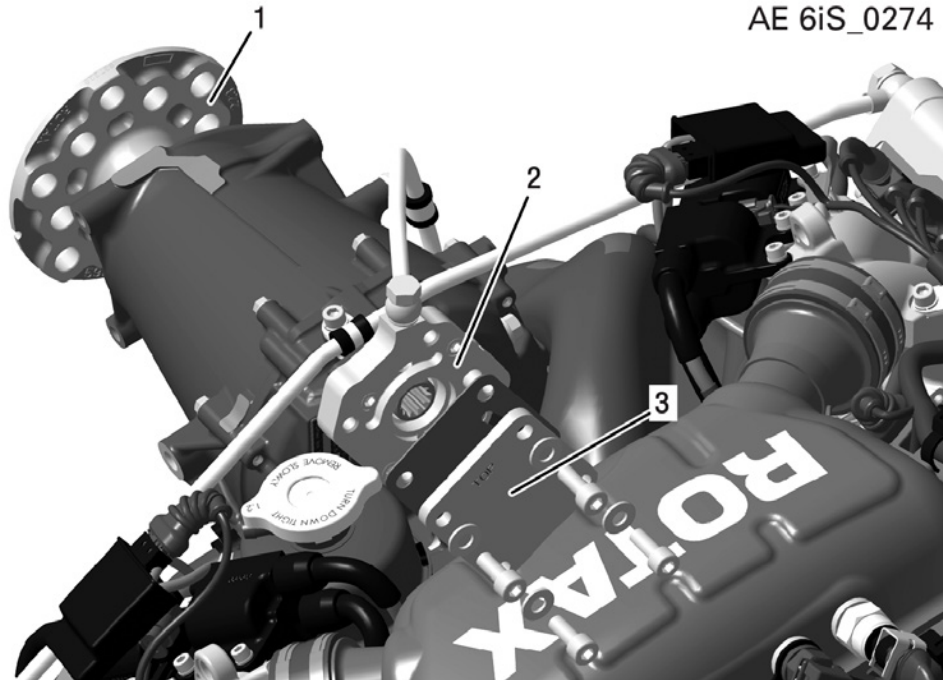

Figure 4.3: Interface (configuration 3)

- 1 Propeller shaft (mechanical. Interface)      2 Governor flange (hydraulic. Interface)  
3 Cover plate

**NOTE**

*The cover used for delivery needs to be removed before engine operation. The cover may not be used in operational condition.*

**BRP-Rotax**  
INSTALLATION MANUAL

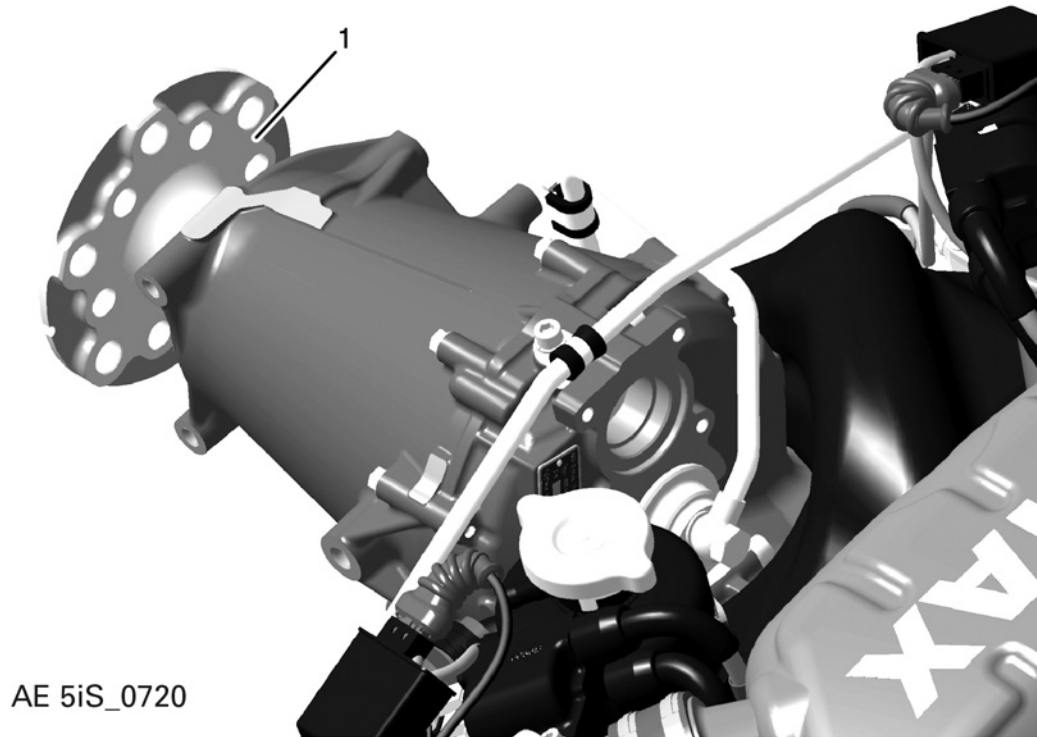

AE 5iS\_0720

Figure 4.4: Interface (configuration 2)

1 *Propeller shaft (mechanical. Interface)*

# BRP-Rotax INSTALLATION MANUAL

## MECHANICAL INTERFACES

### Propeller shaft flange

The propeller in tractor or pusher arrangement must be fitted on the propeller flange in accordance with applicable regulations. As required utilize one of three possible pitch circle diameters (P.C.D.) on the flange.

**NOTICE**

**Modification of the propeller shaft is not permitted.**

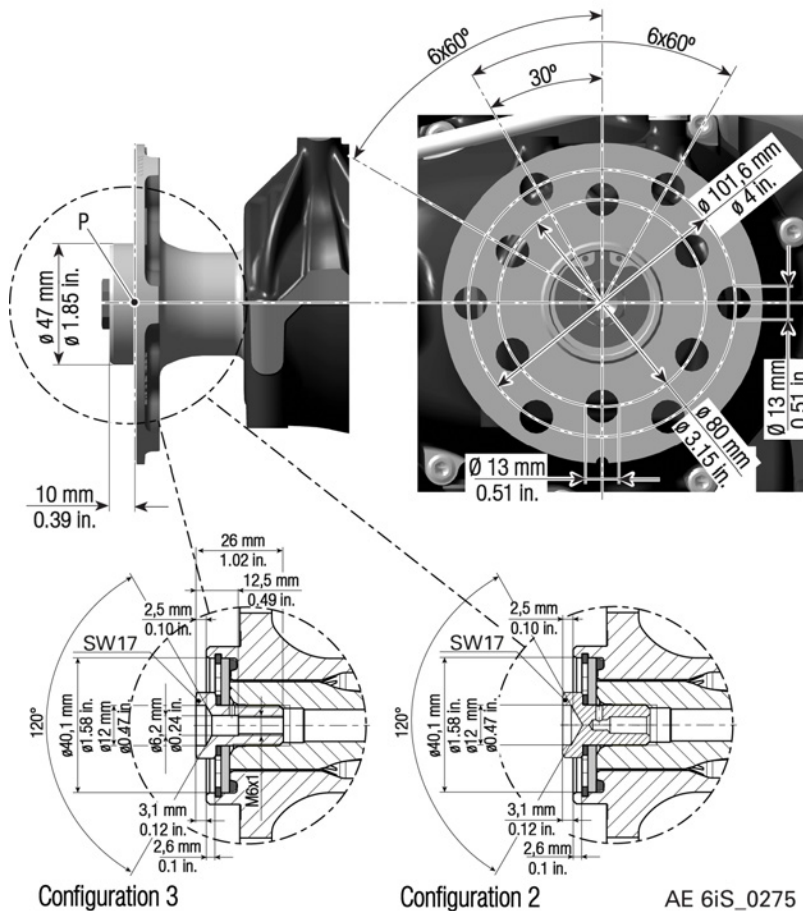

Figure 4.5: Propeller shaft flange

**NOTICE**

**Propeller hub has to be centered on diameter 47 mm (1.85 in.).**



# BRP-Rotax INSTALLATION MANUAL

Interface Parameter	Value
Pitch circle diameter 80 mm (3.15 in.)	6x through holes 13 mm (0.51 in.)
Pitch circle diameter 101.6 mm (4 in.)	6x through holes 13 mm (0.51 in.)
Hub diameter	47 mm (1.85 in.)
Gear transmission	$i=2.54$ . Propeller shaft turns with 0.395 times engine speed.

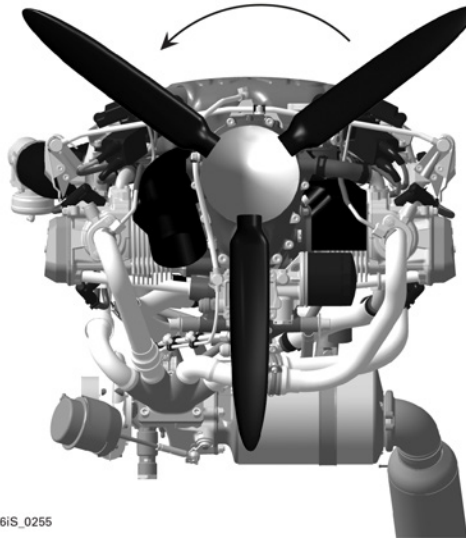

AE 6IS\_0255

Figure 4.6: Direction of rotation

**BRP-Rotax**  
**INSTALLATION MANUAL**

**HYDRAULIC GOVERNOR FOR CONSTANT SPEED PROPELLER**

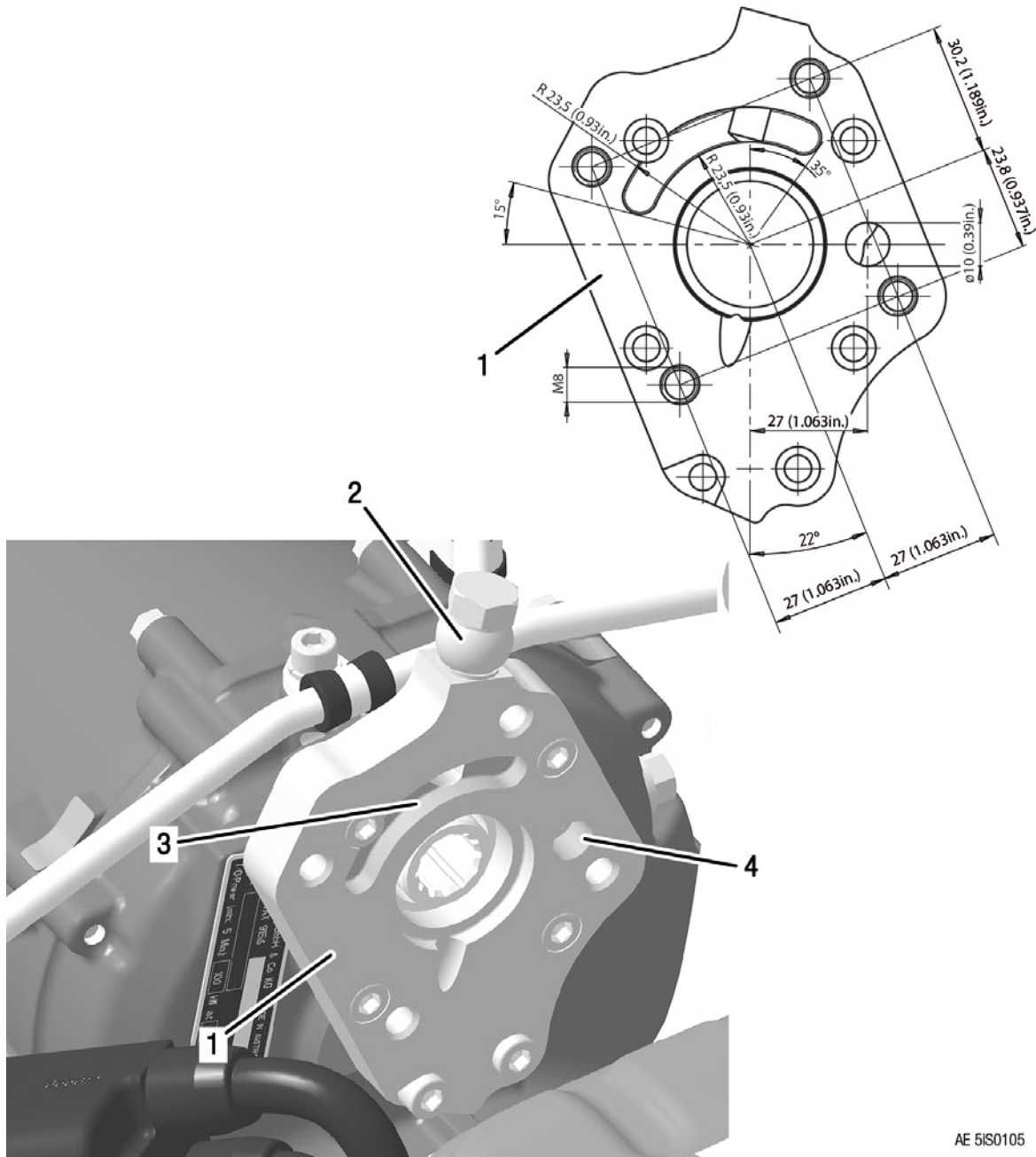

AE 5IS0105

Figure 4.7

- |                   |                           |
|-------------------|---------------------------|
| 1 Governor flange | 2 Pressure oil line assy. |
| 3 Oil inlet       | 4 Oil outlet              |

# BRP-Rotax INSTALLATION MANUAL

## Drive

Drive via propeller gearbox.

Position of the propeller connection on the governor flange:

x-axis [mm/in]	y-axis [mm/in]	z-axis [mm/in]
-206.3 (-8.12)	0	51.5 (2.03)

## Connection

### NOTICE

**Obey the manufacturers instructions!**

## Technical Data

Gear ratio from crankshaft to hydraulic governor is 1.842, i.e. the propeller governor runs at 0.54 times engine speed.

<b>Mounting pad</b>	AND20010
<b>Thread size</b>	M8
<b>Thread length</b>	max. 14 mm (0.55 in)
<b>Toothing</b>	Internal spline 20/40 SMS 1834 NA 14x1,27x30x12
<b>Power input</b>	max. 600 W
<b>Operating pressure</b>	max. 30 bar (435 psi)

**BRP-Rotax**  
INSTALLATION MANUAL

INTENTIONALLY LEFT  
BLANK

**BRP-Rotax**  
**INSTALLATION MANUAL**

**Chapter: 72-00-00**  
**ENGINE**

**TOPICS IN THIS CHAPTER**

**System description** ..... **3**  
    System limitations ..... 7

**Interface description** ..... **9**  
    Interface overview ..... 9  
    Mechanical interfaces ..... 9

**Installation notes** ..... **13**  
    Engine suspension ..... 13

**BRP-Rotax**  
INSTALLATION MANUAL

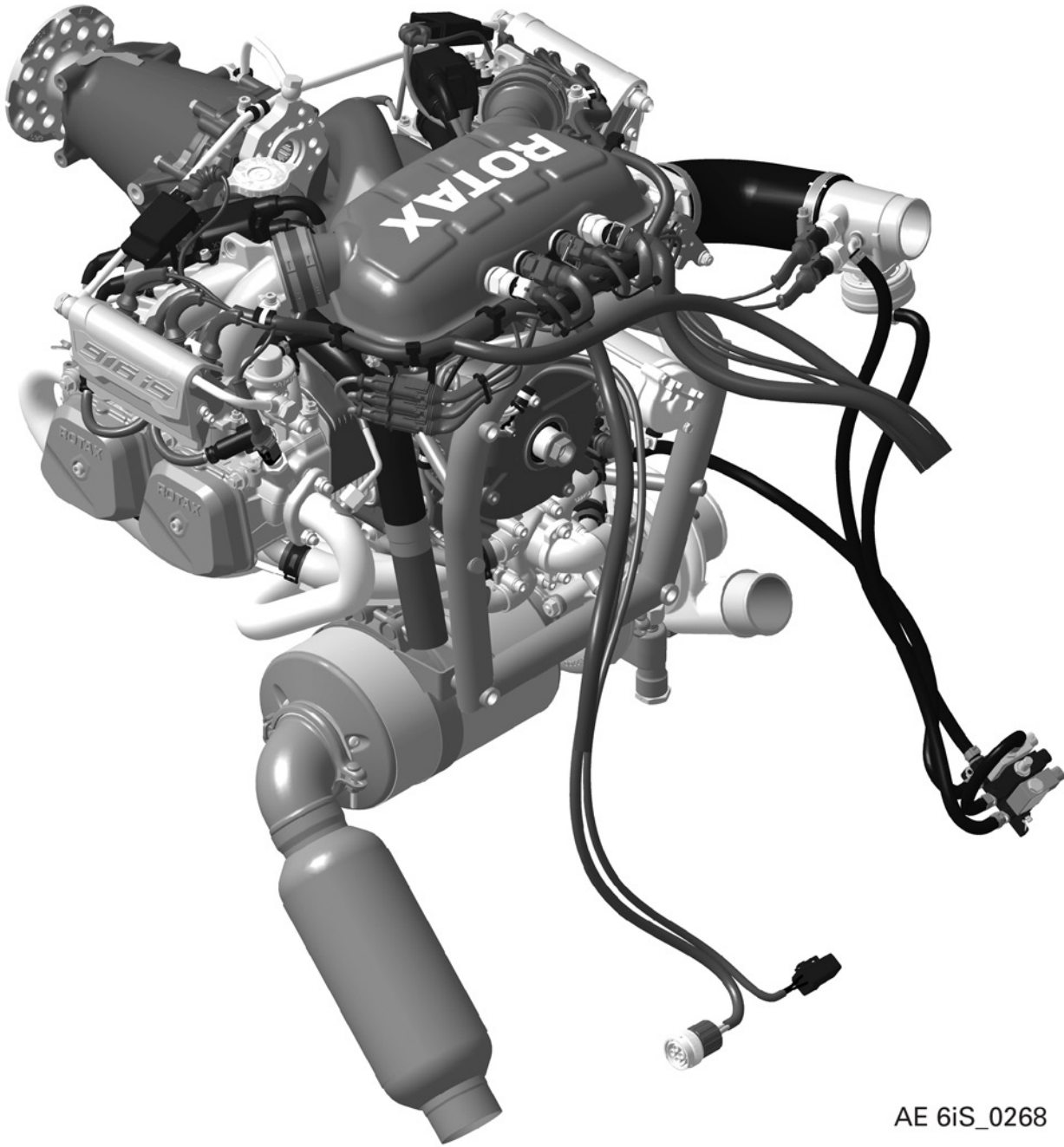

AE 6iS\_0268

Figure 5.1: Engine, TYPICAL

**BRP-Rotax**  
**INSTALLATION MANUAL**

**SYSTEM DESCRIPTION**

For a detailed System description refer to the latest issue of the Operators Manual (OM).

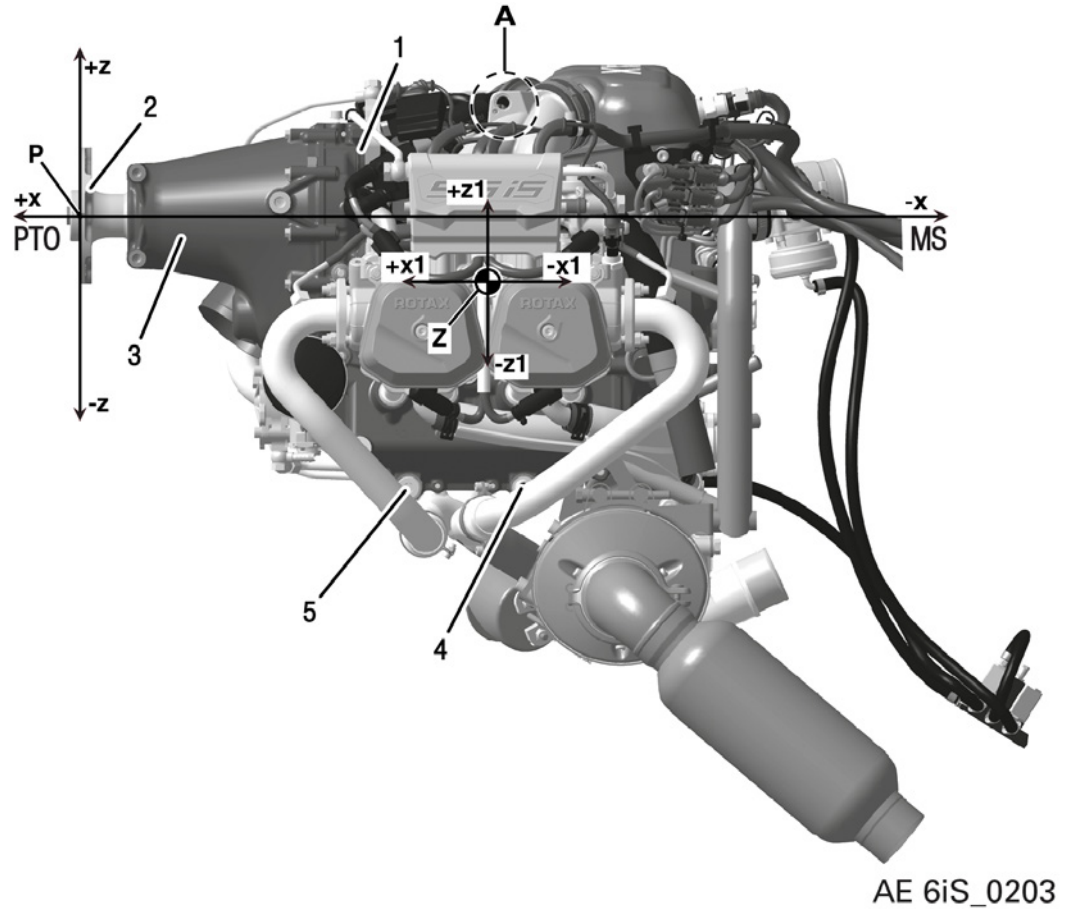
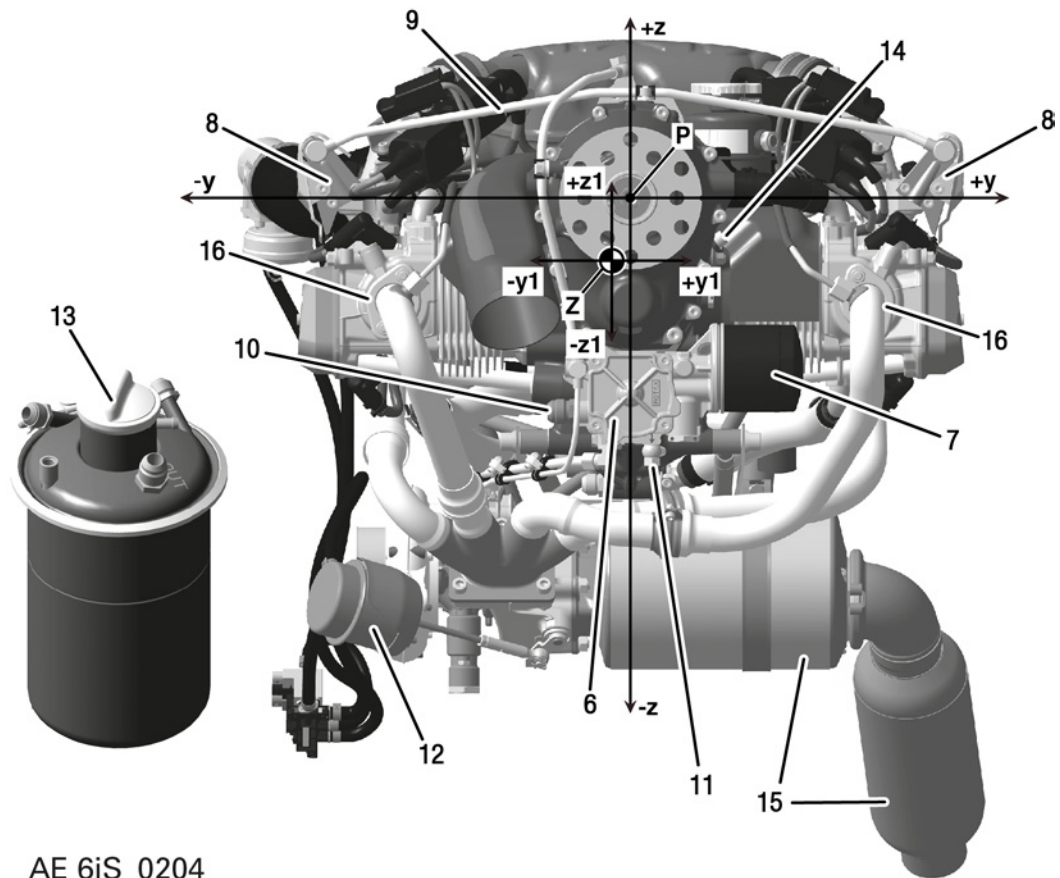

Figure 5.2: Engine side view

- |   |                            |   |  |
|---|----------------------------|---|--|
| 1 | Engine serial number       | 2 | Propeller flange                                 |
| 3 | Propeller gearbox          | 4 | Connection for return line, both sides mandatory |
| 5 | Connection for return line | A | Attachment points (for engine transport)         |
| Z | Center of gravity (Z)      | P | Reference coordinate system (X, Y, Z)            |

**BRP-Rotax**  
INSTALLATION MANUAL



AE 6iS\_0204

Figure 5.3: Engine Front view

- |    |  |    |   |
|----|--|----|---|
| 6  | <i>Oil pump housing</i>                  | 7  | <i>Oil filter</i>                                   |
| 8  | <i>Fuel rail left/right</i>              | 9  | <i>Fuel line assy.</i>                              |
| 10 | <i>Connection for oil feed line</i>      | 11 | <i>Connection for turbo oil return line to tank</i> |
| 12 | <i>Wastegate actuator assy.</i>          | 13 | <i>Oil tank (metric or UNF)</i>                     |
| 14 | <i>Crankshaft locking screw position</i> | 15 | <i>Muffler assy.</i>                                |
| 16 | <i>Exhaust flange</i>                    |    |   |



# BRP-Rotax INSTALLATION MANUAL

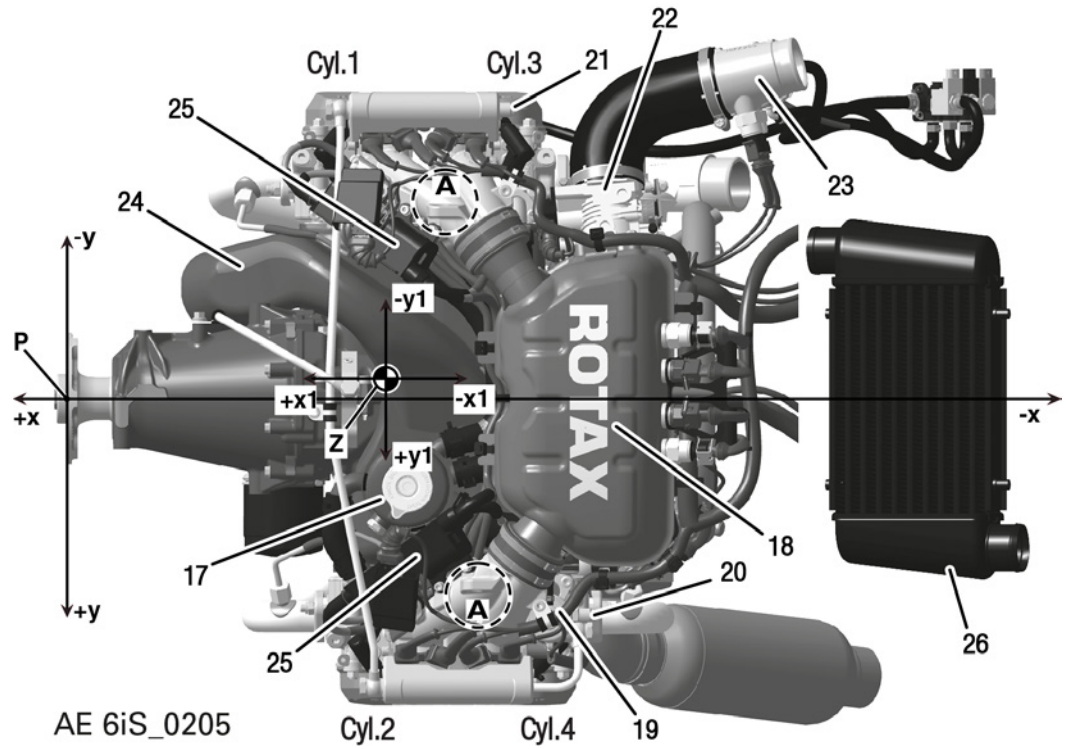
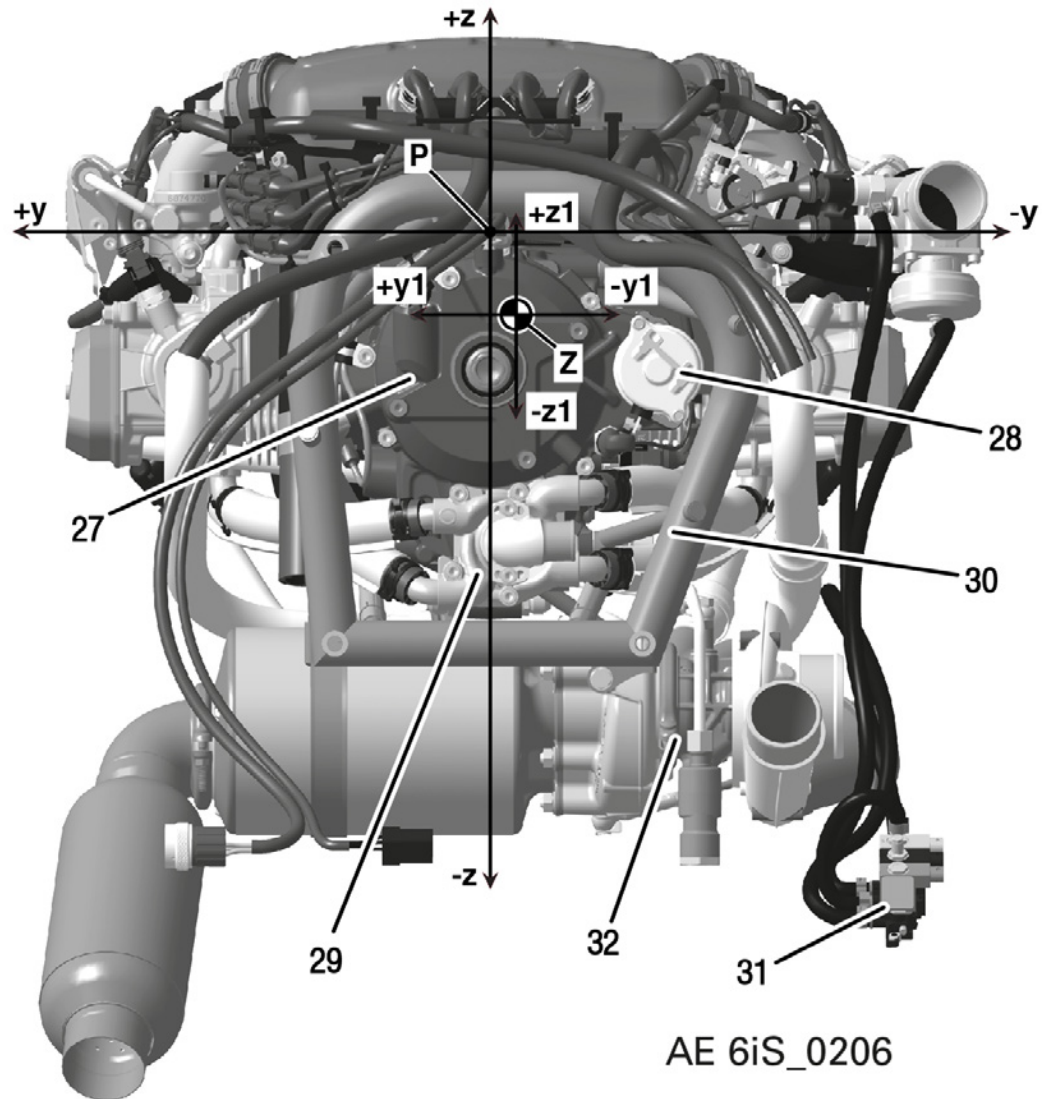

Figure 5.4: Top view

- |    |  |    |                                 |
|----|--|----|---------------------------------|
| 17 | Expansion tank assy.                   | 18 | Airbox                          |
| 19 | Fuel pressure regulator                | 20 | Connection for fuel return line |
| 21 | Connection for fuel feed line          | 22 | Throttle body                   |
| 23 | Pop off valve                          | 24 | Cooling air baffle              |
| 25 | Dual ignition coils                    | 26 | Intercooler                     |
| A  | Attachment points (for engine lifting) |    |                                 |

**BRP-Rotax**  
INSTALLATION MANUAL



AE 6iS\_0206

Figure 5.5: Rear view

- |    |                      |    |                                      |
|----|----------------------|----|--------------------------------------|
| 27 | Ignition housing     | 28 | Electric starter                     |
| 29 | Water pump housing   | 30 | Engine suspension frame (ring mount) |
| 31 | Solenoid Valve (PCV) | 32 | Turbocharger assy.                   |

# BRP-Rotax INSTALLATION MANUAL

## SYSTEM LIMITATIONS

**Operating limits** Refer to latest issue of the Operators Manual (OM).

**Installation position** The oil system, fuel system and the cooling system are unsuitable for upside-down / inverted installation of the engine.

System Limit	Min.	Max.
Static roll angle $\beta$		40°

The oil level should be in the upper half (between the “50%” and the “Max.” mark) and should never fall below the “Min.” mark. For the oil level measuring procedure refer to the latest version of the respective Operators Manual (OM).

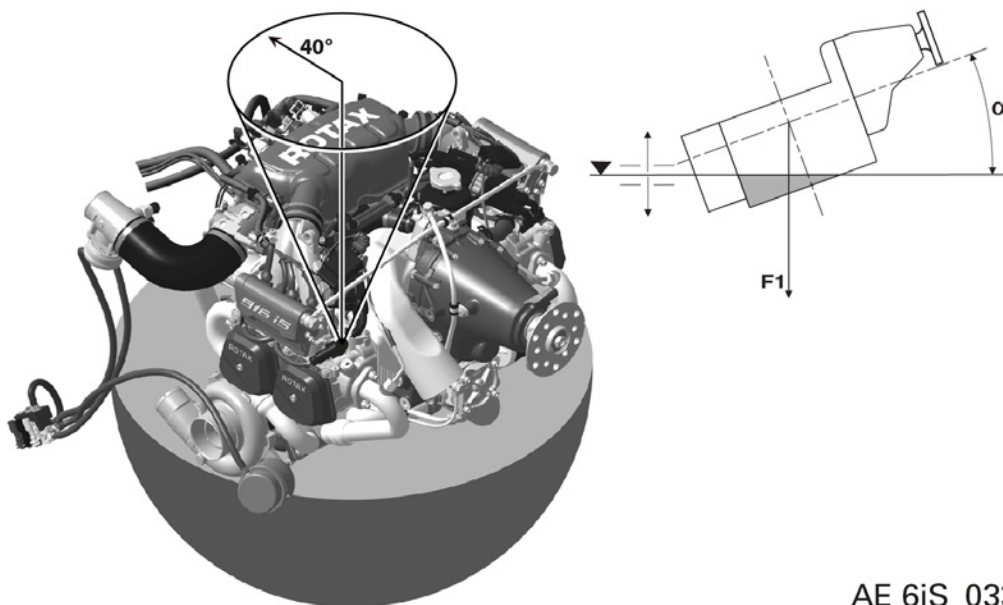

AE 6iS\_0339

Figure 5.6: Bank angle

Angle/force	Description
$\alpha$	Bank or rotation
F1	Gravity

**Attachment points**

For mounting the engine on the engine suspension, R2, R3, L3 and L2 of attachment points must be used. All used screws must not touch engine components.

# BRP-Rotax INSTALLATION MANUAL

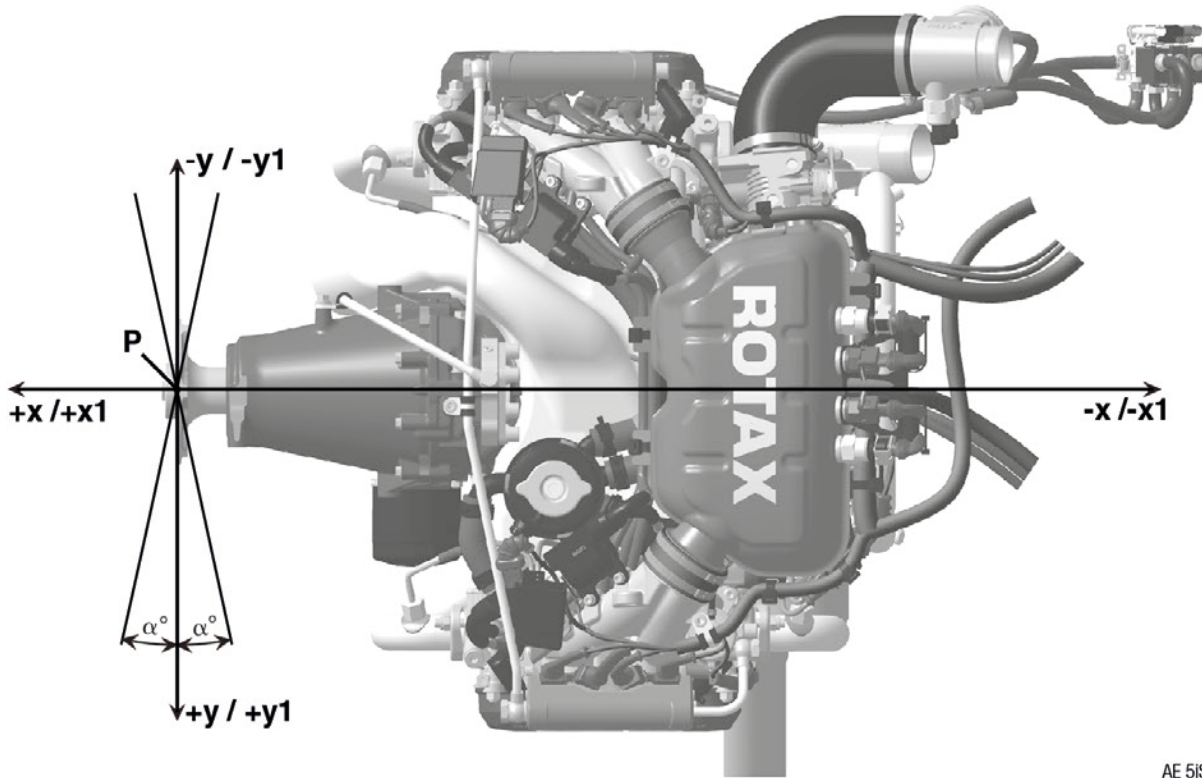

AE 5IS\_0165

Figure 5.7: Propeller and vertical axis TYPICAL

## Propeller axis

The y1-axis must be perpendicular to the longitudinal axis of the aircraft.

System Limit	Min.	Max.
Permissible deviation from perpendicular ( $\alpha$ )	- 10°	+ 10°

# BRP-Rotax INSTALLATION MANUAL

## INTERFACE DESCRIPTION

### INTERFACE OVERVIEW

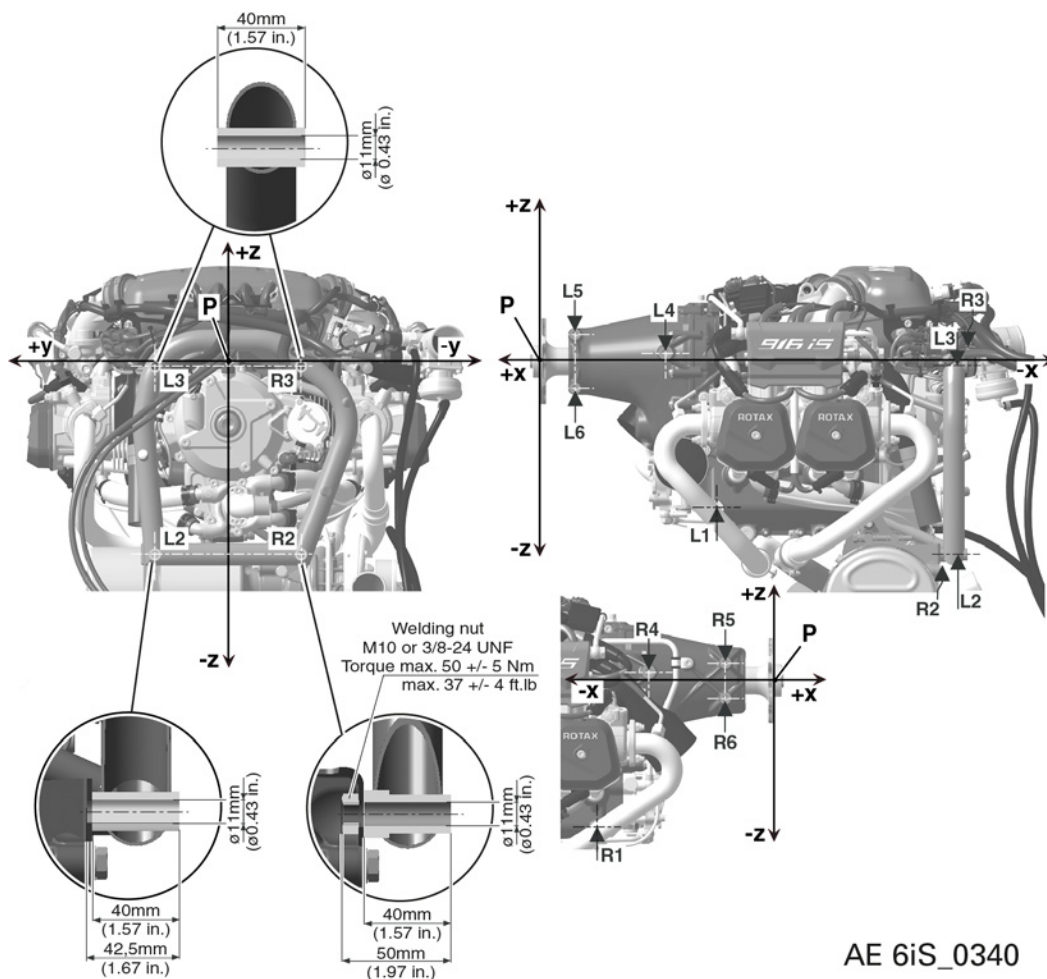

Figure 5.8: Attachment points

### MECHANICAL INTERFACES

Attachment points

Interface Parameter	Value			
	L1	R1	L2	R2
x-axis (in)	- 253.5 mm (-99.8 in.)		- 615 mm (-24.21 in.)	
y-axis (in)	-71 mm (-2.8 in.)		105 mm (4.13 in.)	-105 mm (-4.13 in.)
z-axis (in)	-211 mm (-8.31 in.)		-277 mm (-10.91 in.)	

## BRP-Rotax INSTALLATION MANUAL

Interface Parameter	Value			
Attachment points	L1	R1	L2	R2
Thread	M10		—	
Max. usable Thread length	25 mm (0.98 in.)			

Interface Parameter	Value			
Attachment points	L3	R3	L4	R4
x-axis (in)	- 615 mm (-24.21 in.)		- 181 mm (-7.13 in.)	
y-axis (in)	105 mm (4.13 in.)	-105 mm (-4.13 in.)	90 mm (3.54 in.)	-90 mm (-3.54 in.)
z-axis (in)	-7 mm (-0.28 in.)		12.2 mm (0.48 in.)	
Thread	—		M10	
Max. usable Thread length			16 mm (0.63 in.)	

Interface Parameter	Value			
Attachment points	L5	R5	L6	R6
x-axis (in)	- 51 mm (-1.97 in.)	- 71 mm (-2.79 in.)	- 51 mm (-1.97 in.)	- 71 mm (-2.79 in.)
y-axis (in)	48 mm (1.89 in.)	-64.5 mm (-2.54 in.)	48 mm (1.89 in.)	-64.5 mm (-2.54 in.)
z-axis (in)	25.4 mm (1.00 in.)	39 mm (1.53 in.)	-25.4 mm (-1.00 in.)	-39 mm (-1.53 in.)
Thread	M8		M8	
Max. usable Thread length	20 mm (0.79 in.)		20 mm (0.79 in.)	

### ⚠ WARNING

#### Non-compliance can result in serious injuries or death!

The aircraft or fuselage manufacturer must design the engine suspension so that it can safely carry the maximum occurring operational loads without exceeding the max. allowable forces and bending moments on the engine housing and attachment points.  
Tighten all engine suspension screws as specified by the aircraft manufacturer.

**BRP-Rotax**  
INSTALLATION MANUAL

**Weight**

Engine component	Weight
<b>Base engine with gearbox:</b>	75.44 kg (166.3 lb)
Governor drive add on weight version 3	0.60 kg (1.32 lb)
Cooling air baffle	0.38 kg (0.838 lb)
PCV	0.35 kg (0.771 lb)
Oil tank	1.50 kg (3.30 lb)
Intercooler	1.65 kg (3.65 lb)
ECU	1.13 kg (2.49 lb)
Fusebox 916 I A Series	2.02 kg (4.45 lb)
Fusebox 916 I C24 Series	1.84 kg (4.06 lb)
Ambient sensors	0.06 kg (0.132 lb)
Wiring harness 916 I A Series	2.50 kg (5.51 lb)
Wiring harness 916 I C24 Series	1.84 kg (4.06 lb)
Intermediate flange with overboost valve, air hose and clamps	0.78 kg (1.72 lb)
AD-DC Converter assy.	1.68 kg (3.70 lb)
Starter Relay	0.14 kg (0.308 lb)

# BRP-Rotax INSTALLATION MANUAL

## Centre of gravity of engine

Center of gravity (COG) position information only considers the engine itself. Parts without a specific installation position relative to the reference coordinate system are not considered.

### NOTE

*All distances are given in relation to the reference coordinate system (P).*

### NOTE

*The COG will slightly change when adjusting the orientation of the resonator.*

Axis	Center of gravity
X-axis	- 377 mm (-14.84 in.)
Y-axis	- 9.4 mm (-0.35 in.)
Z-axis	- 115 mm (-4.52 in.)

## Moments of inertia (relative to COG)

### NOTE

*The MOI will slightly change when adjusting the orientation of the resonator.*

Axis	Moment of inertia
X-axis	2467496 kg*mm <sup>2</sup>
Y-axis	2600923 kg*mm <sup>2</sup>
Z-axis	2752637 kg*mm <sup>2</sup>

## Dimensions

### NOTE

*The Overall length and height may vary by adjusting the orientation of the resonator.*

Description	Dimension
Overall length (w/o intercooler and hoses)	657 mm (25.87 in.)
Overall length with suspension frame	657 mm (25.87 in.)
Overall height (w/o exhaust system and suspension frame)	398 mm (15.67 in.)
Overall height with exhaust system	673 mm (26.50 in.)
Overall height with engine suspension frame	430 mm (16.93 in.)
Overall width (w/o exhaust end pipe, intercooler and hoses)	578 mm (22.76 in.)



# BRP-Rotax INSTALLATION MANUAL

## INSTALLATION NOTES

### General

The representation of components in this chapter which are not within scope of the delivery is only symbolic. The design shown in this chapter does not represent a specified execution but should support the understanding of the system.

The final design, the selection and specification of parts according to the respective applicable regulations, the consideration of the system limitations and interface description as well as the comprehension of the operating limits in every operational state is in the responsibility of the aircraft manufacturer.

The aircraft manufacturer has to make sure that the operating limits given in the Operators Manual (OM) can be supervised by the pilot. The execution of the installation must allow the operation of the engine according to the Operators Manual (OM).

### ENGINE SUSPENSION

#### NOTICE

**During engine installation take into account the total engine weight and ensure careful handling.**

The rubber mounts for neutralizing vibrations and other engine suspension components are not in the scope of delivery. Those components must be designed, selected and tested on vibration behavior during ground runs and flight testing at specified loads.

#### NOTICE

**The engine suspension must be designed to prevent excessive engine movement and to minimize noise emission and vibration on the airframe.**

The engine suspension is determined essentially by the aircraft design. Four attachment points are provided on the engine suspension frame assy.

The engine will be supplied with a well tried and certified suspension frame for attachment on the fireproof bulkhead. The exhaust system and the turbo charger are supported on this frame, too. The installation into the aircraft is as generally practised by captive rubber mounts which ensure also to reduce vibrations and sound transmission from engine to aircraft frame.

# BRP-Rotax INSTALLATION MANUAL

## ⚠ WARNING

The hex. screws M10x60 on the attachment points R2 and L2 are only used for transport securing but must never be utilized for engine suspension. See interface overview. Therefore, use the ROTAX engine suspension frame and the 4 stated attachment points R2, L2, R3, L3.

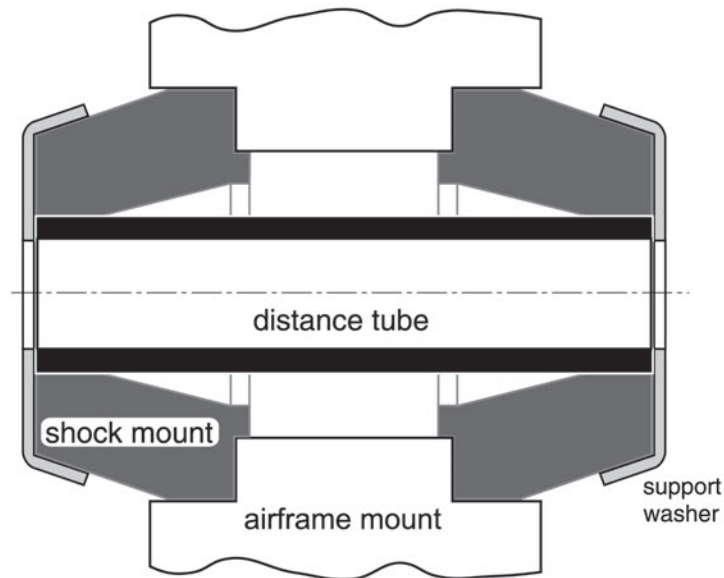

Figure 5.9: Damping element engine suspension

Standard aircraft industry damping elements (e.g. Lord) are suitable and need to be chosen according to the aircraft specific design requirements. Check with the relevant equipment manufacturer.

The vibration and acoustic insulation factor depends on the airframe.

**BRP-Rotax**  
**INSTALLATION MANUAL**

**Chapter: 72-60-00**  
**AIR INTAKE SYSTEM**

**TOPICS IN THIS CHAPTER**

**System description** ..... **3**  
    System limitations ..... 3

**Interface description** ..... **6**  
    Interface overview ..... 6  
    Mechanical interfaces ..... 7  
    Pneumatic interfaces ..... 8  
    Electrical interfaces ..... 9

**Installation notes** ..... **10**  
    Installation overview ..... 10

**BRP-Rotax**  
**INSTALLATION MANUAL**

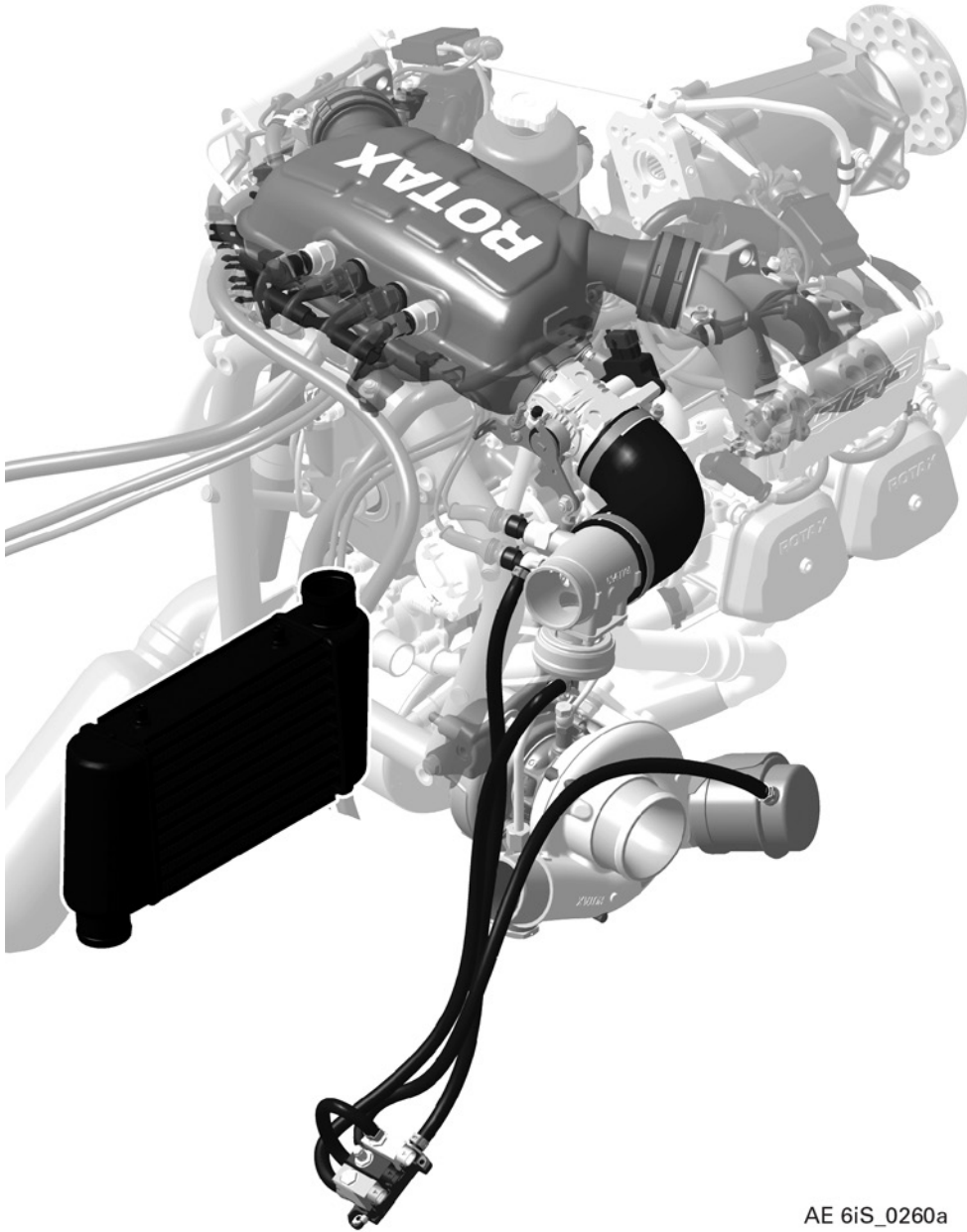

AE 6iS\_0260a

Figure 6.1: Air intake system

# BRP-Rotax INSTALLATION MANUAL

## SYSTEM DESCRIPTION

For a detailed System description refer to the latest issue of the Operators Manual (OM).

### SYSTEM LIMITATIONS

#### Induction air intake

Following requirements may be used:

System Limit	Min.	Max.
Flow rate	400 kg/h	
Pressure loss between ambient pressure and compressor in pressure, caused by the airfilter.		10 mbar (0.14 psi)

Icing in the area of the air intake needs to be avoided. The prevention of icing lies within the aircraft manufacturer's responsibility.

#### Airbox reference pressure

The reference pressure of the fuel system is the airbox pressure.

#### Induction air intake ducting

System Limit	Min.	Max.
Intake pressure loss (Engine Speed: 5500 $\pm$ 50 rpm; Airflow: 360-366 kg/min)		85 mbar (1.23 psi)
Intake pressure loss (Engine Speed: 5800 $\pm$ 50 rpm; Airflow: 384-396 kg/min)		90 mbar (1.30 psi)

#### PCV ducting

All pneumatic connections leading from and to the Pressure Control Valve (PCV) may not be changed. Changes in length and diameter of the connections will have an significant effect on the wastegate control. Depending on the installation heat protection may be required.

System Limit	Min.	Max.
Bending radius on tube centerline	60 mm (2.36 in.)	

#### Valid installation positions

The intercooler as well as the PCV must be installed vibration-decoupled from the engine.

#### Compressor housing

The turbo compression housing must not be rotated. The wastegate functionality can be affected.

# BRP-Rotax

## INSTALLATION MANUAL

### Throttle lever

Adjust Bowden cable such that throttle valve can be fully opened and closed.

Step	Procedure
1	Push to "full throttle", then adjust Bowden cable so that it has 1 mm (0.04 in.) clearance (no tensioning), thereby ensured that throttle valve is completely open.  <b>NOTE</b> <i>Spring pulls the throttle valve to full throttle position.</i>
2	Push to "idle". Set the spring-loaded screw that the throttle lever hits the stop screw with the black cap (maximum setting for lowest idle).
3	If the idling speed is too low, then open throttle lever with the spring-loaded screw until the required idling speed is reached
4	Mark adjustments with locking varnish.

### NOTE

*It is not recommended to install a throttle limiter. With the installation of a throttle limiter, the engine can not reach its nominal power.*

## BRP-Rotax INSTALLATION MANUAL

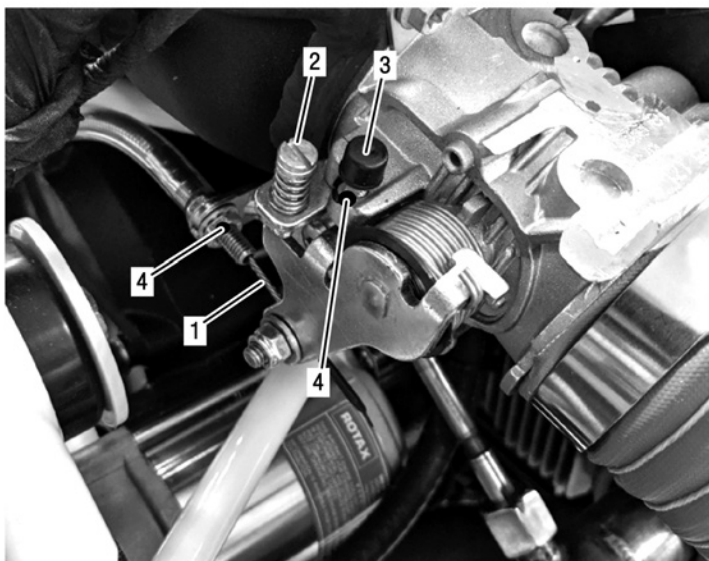

AE 516\_0773

Figure 6.2: Figure shows idle position

- |   |  |   |   |
|---|--|---|---|
| 1 | Bowden cable   | 2 | Spring-loaded screw (idle speed adjustment) |
| 3 | Screw with black cap (maximum setting for lowest idle speed) | 4 | Locking varnish                             |

### **⚠ WARNING**

#### **Non-compliance can result in serious injuries or death!**

With throttle lever not connected the throttle valve will remain fully open. The starting position of the throttle valve is therefore full throttle! Therefore never start the engine without connecting the throttle lever first.

### **⚠ WARNING**

#### **Non-compliance can result in serious injuries or death!**

The cable actuations being used must not be affected at all by vibrations emanating from the engine or the airframe.

**BRP-Rotax**  
INSTALLATION MANUAL

**INTERFACE DESCRIPTION**

**INTERFACE OVERVIEW**

Interface  
overview

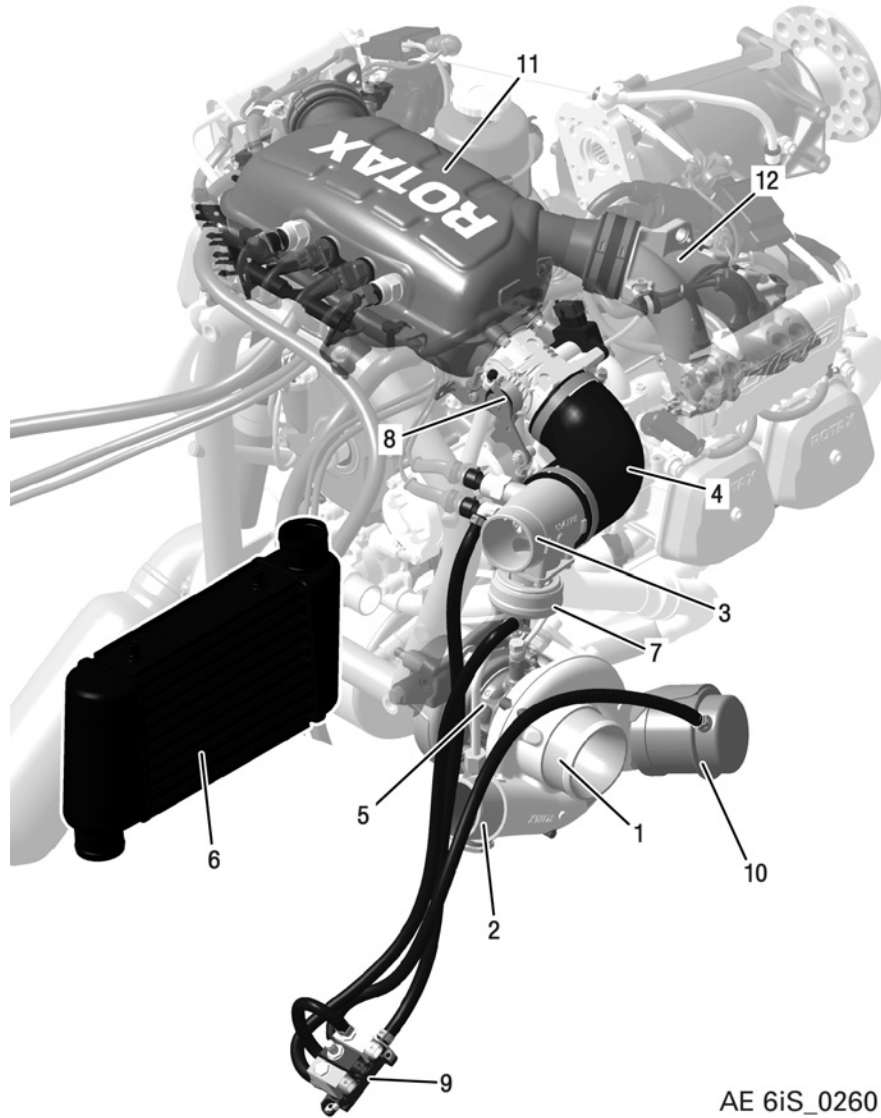

Figure 6.3: Air intake: Interface overview and components

- |   |   |   |  |
|---|---|---|--|
| 1 | Air filter connection                   | 2 | Connection turbocharger to intercooler           |
| 3 | Connection intercooler to pop off valve | 4 | Air intake hose (pop off valve to throttle body) |
| 5 | Turbocharger                            | 6 | Intercooler                                      |
| 7 | Pop off valve                           | 8 | Throttle body                                    |



# BRP-Rotax INSTALLATION MANUAL

- |                                |                               |
|--------------------------------|-------------------------------|
| 9 Pressure control valve (PCV) | 10 Actuator assy. (wastegate) |
| 11 Airbox                      | 12 Intake manifold            |

## MECHANICAL INTERFACES

### Pressure control valve (PCV)

Interface Parameter	Min.	Max.
Tightening torque	–	1 Nm (9 in. lb)

### Pressure control valve (PCV)

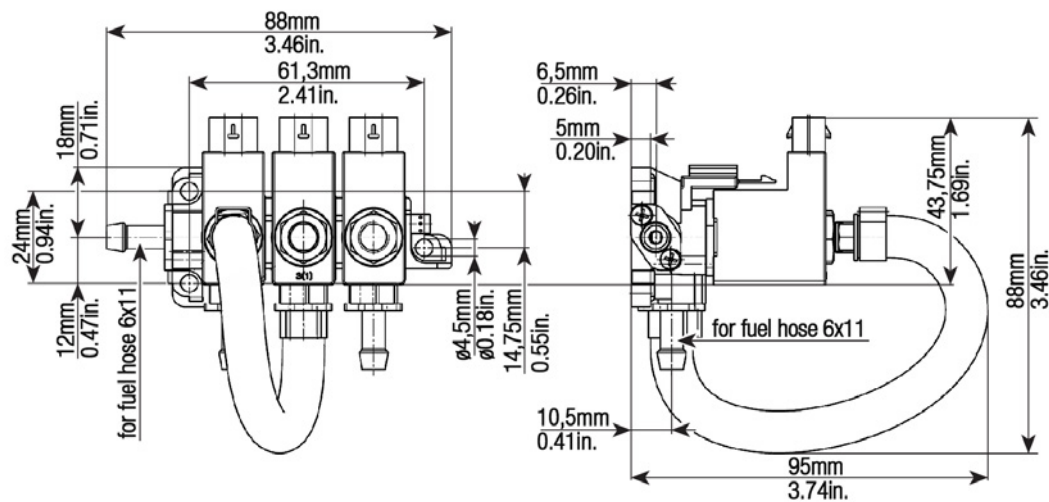

AE 6iS\_0341

Figure 6.4: Connection and dimensions

### Throttle body

Interface Parameter	Min.	Max.
Tightening torque (Bowden cable to throttle arm)	4 Nm (35 in. lb) (suitable for flexible cable), 1.5 mm (0.06 in.) steel rope or single-strand wire	—
Cable travel	65 mm (2.56 in.)	—
Actuating force	7.5 N (1.69 lbs.)	20 N (4.5 lbs)
Max. permissible actuating force	—	20 N (4.5 lbs)

**Connection:** Set screw M6x12 mm

### Intercooler



For details see SI-PAC-005.

# BRP-Rotax INSTALLATION MANUAL

## PNEUMATIC INTERFACES

### Airfilter connection

See figure Connection on turbocharger

Interface Parameter	Min.	Max.
Slip-on length	30 mm (1.18 in.)	-

### NOTE

*Use only filter elements which will not tend to restrict the flow when in contact with water.*

### Turbocharger to intercooler

Connection on turbocharger:

Interface Parameter	Min.	Max.
Slip-on length	30 mm (1.18 in.)	-

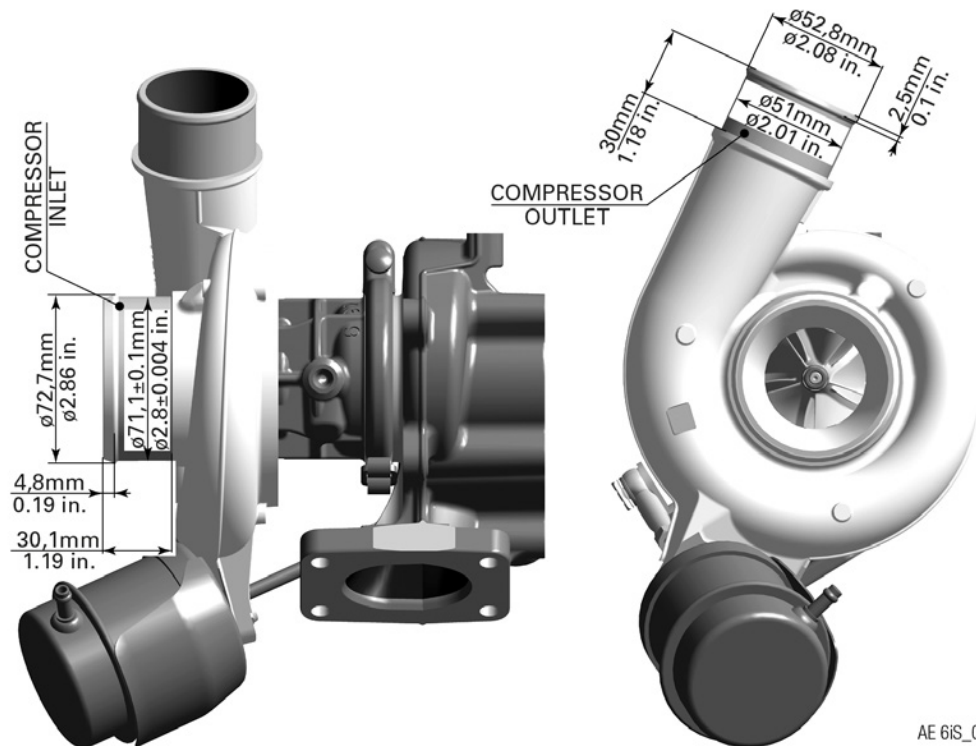

Figure 6.5: Connection on turbocharger

# BRP-Rotax INSTALLATION MANUAL

## Connection on intercooler:

Interface Parameter	Min.	Max.
Slip-on length	32 mm (1.26 in.)	-

## Intercooler to overboost valve

Interface Parameter	Min.	Max.
Slip-on length	18 mm (0.71 in.)	

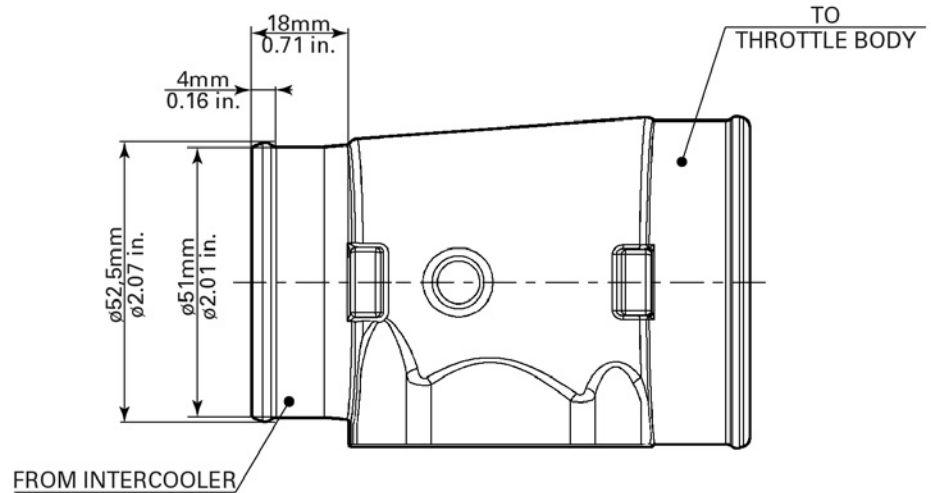

AE 5IS\_0374

Figure 6.6: Overboost valve

**Connection on throttle body:** Install the delivered hose (scope of supply) to the correct side of the overboost valve, recheck if it fits.

## ELECTRICAL INTERFACES

### PCV sockets

The appropriate connectors on the wiring harness as well as the corresponding sockets on the PCV are color coded.  
To avoid inappropriate behavior of the wastegate the correct linkage needs to be ensured.

# BRP-Rotax INSTALLATION MANUAL

## INSTALLATION NOTES

### General

The representation of components in this chapter which are not within scope of the delivery is only symbolic. The design shown in this chapter does not represent a specified execution but should support the understanding of the system.

The final design, the selection and specification of parts according to the respective applicable regulations, the consideration of the system limitations and interface description as well as the comprehension of the operating limits in every operational state is in the responsibility of the aircraft manufacturer.

The aircraft manufacturer has to make sure that the operating limits given in the Operators Manual (OM) can be supervised by the pilot. The execution of the installation must allow the operation of the engine according to the Operators Manual (OM).

## INSTALLATION OVERVIEW

### Pneumatic diagram

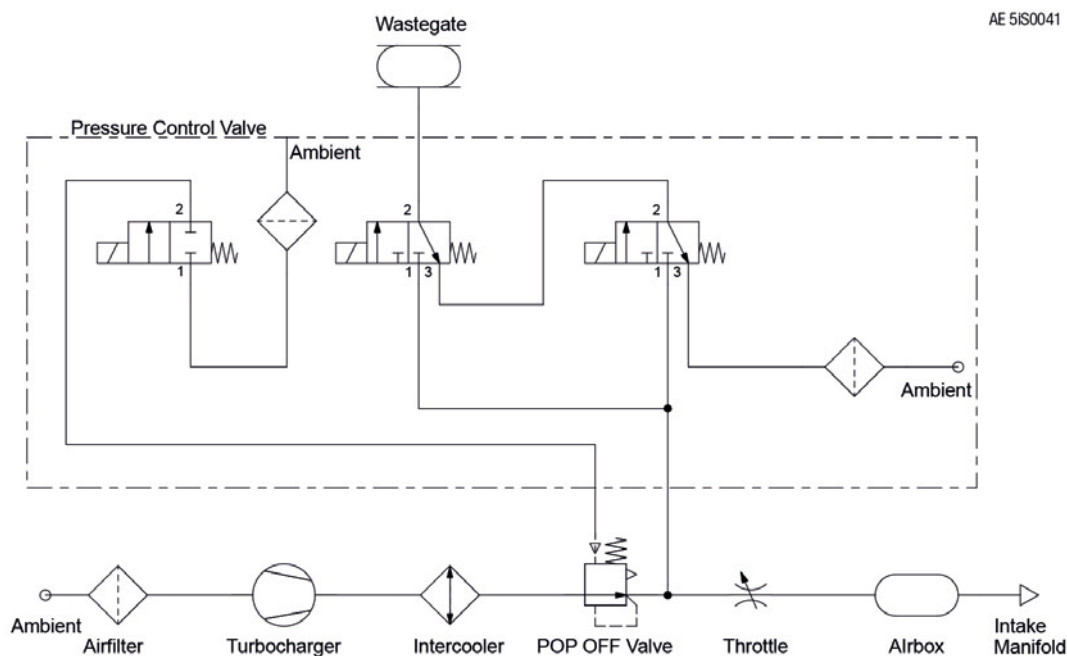

Figure 6.7: Pneumatic diagram

### Connection between compressor outlet and intercooler

Temperature-resistant hoses must be used.

**BRP-Rotax**  
**INSTALLATION MANUAL**

**Chapter: 73-00-00**  
**ENGINE – FUEL AND CONTROL**

**TOPICS IN THIS CHAPTER**

<b>System description</b> .....	<b>3</b>
System limitations .....	3
<b>Interface description</b> .....	<b>4</b>
Interface overview .....	4
Hydraulic interfaces .....	6
Electrical interfaces – 916 I Type A .....	6
Electrical interfaces – 916 I Type C24 .....	7
Mechanical interfaces .....	7
<b>Installation notes</b> .....	<b>8</b>
Installation overview .....	9
Fuel lines .....	10
Inlet line .....	10
Return line .....	10
Bypass line .....	10
Coarse filter .....	11
Water trap, gascolator .....	11
Fine filter .....	11
Fuel pump .....	12
Fuel pressure sensor .....	12
Fuel pressure regulator .....	12
Fuel tank .....	12
Fuel shut off valve .....	13

**BRP-Rotax**  
**INSTALLATION MANUAL**

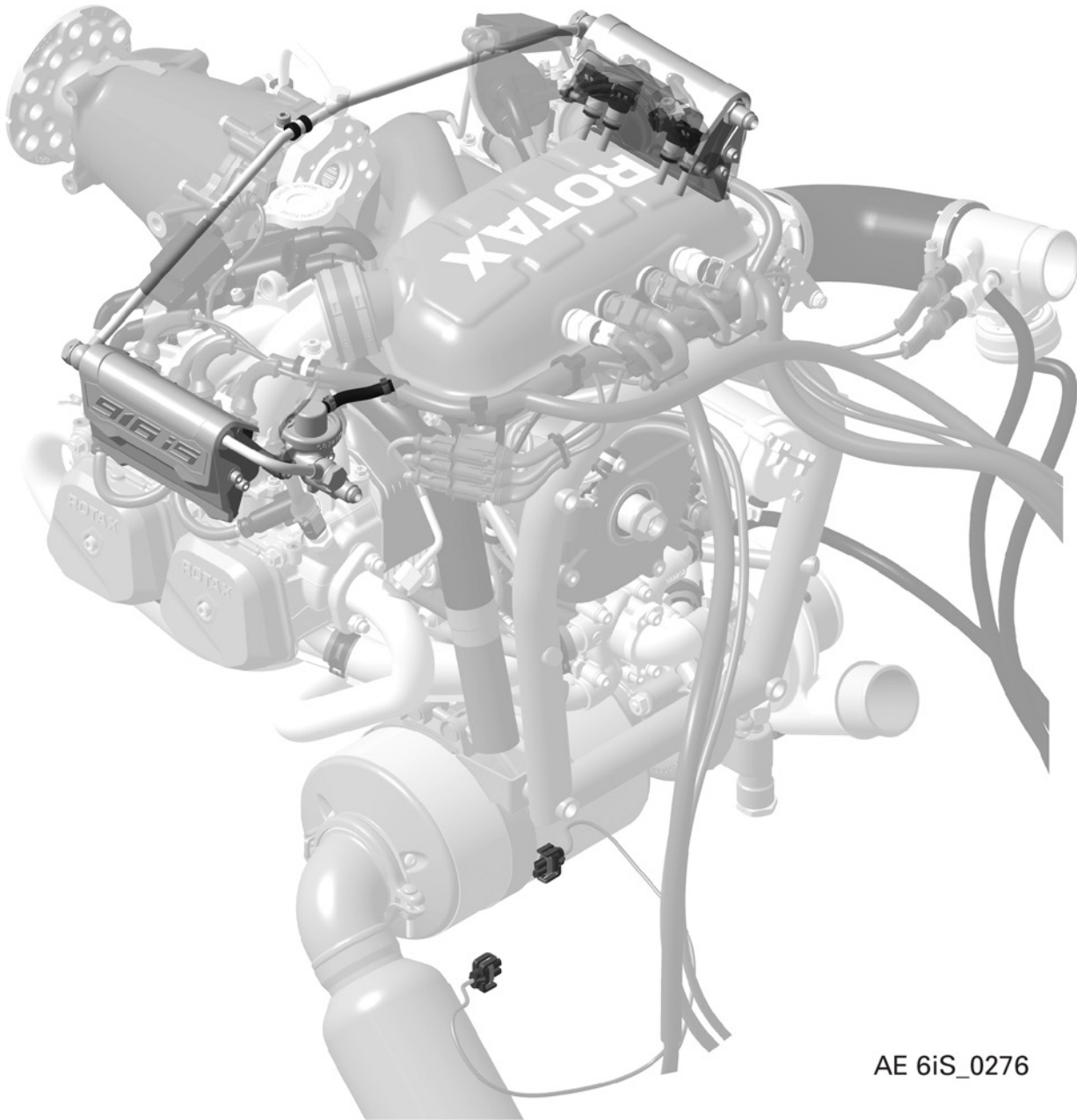

Figure 7.1: Fuel System

**BRP-Rotax**  
INSTALLATION MANUAL

**SYSTEM DESCRIPTION**

For a detailed System description refer to the latest issue of the Operators Manual (OM).

**SYSTEM LIMITATIONS**

**Operating limits** Refer to latest issue of the Operators Manual (OM).

**BRP-Rotax**  
**INSTALLATION MANUAL**

**INTERFACE DESCRIPTION**

**INTERFACE OVERVIEW**

**916 i TYPE A**

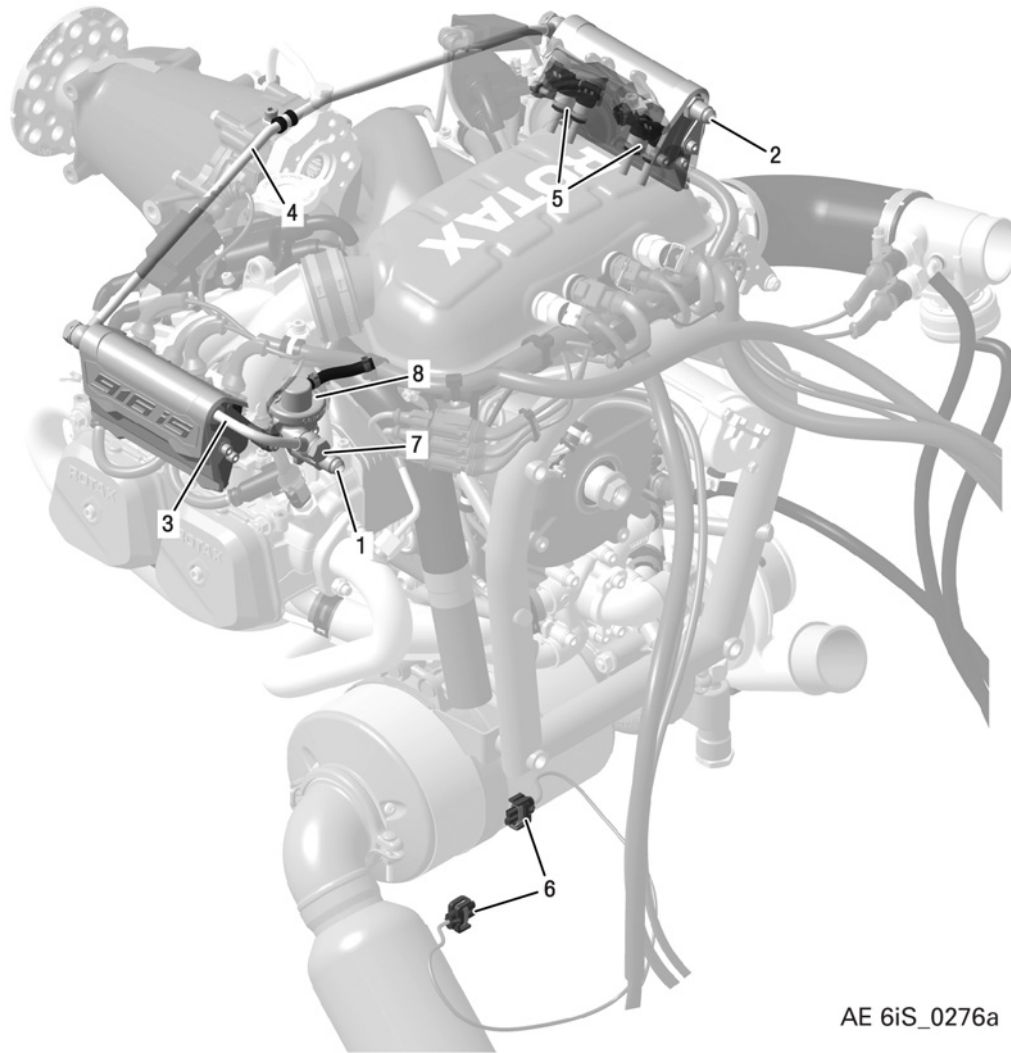

AE 6iS\_0276a

Figure 7.2: Fuel System: Interface overview and components

- |   |   |   |   |
|---|---|---|---|
| 1 | Fuel rail 2/4 outlet line (hydraulic Interface) | 2 | Fuel rail 1/3 feed line (hydraulic Interface) |
| 3 | Fuel rail                                       | 4 | Fuel line assy.                               |
| 5 | Injection valves                                | 6 | Fuel pump connectors (electrical interface)   |
| 7 | Banjo bolt adapter (mechanical interface)       | 8 | Fuel pressure regulator                       |



# BRP-Rotax INSTALLATION MANUAL

916 i TYPE C24

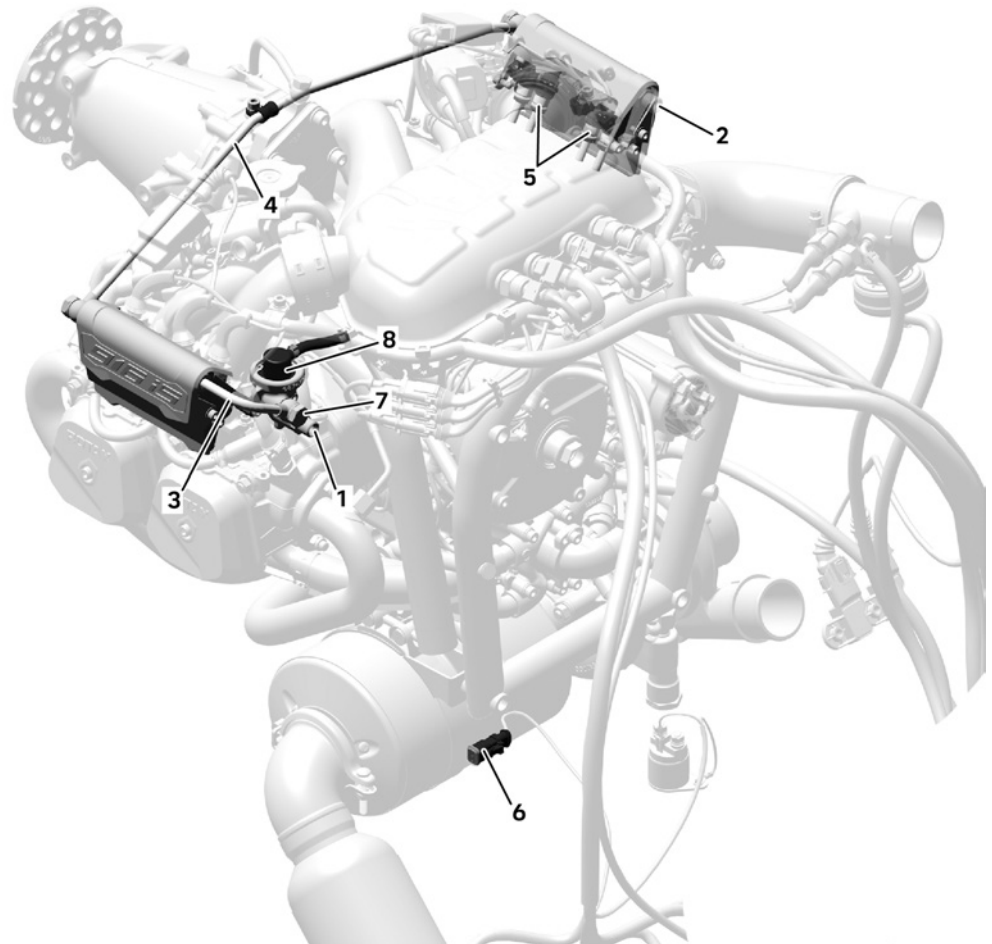

AE\_6iS\_0438

Figure 7.3: Fuel System: Interface overview and components

- |   |   |   |   |
|---|---|---|---|
| 1 | Fuel rail 2/4 outlet line (hydraulic Interface) | 2 | Fuel rail 1/3 feed line (hydraulic Interface) |
| 3 | Fuel rail                                       | 4 | Fuel line assy.                               |
| 5 | Injection valves                                | 6 | Fuel pump connectors (electrical interface)   |
| 7 | Banjo bolt adapter (mechanical interface)       | 8 | Fuel pressure regulator                       |

# BRP-Rotax

## INSTALLATION MANUAL

### HYDRAULIC INTERFACES

NOTICE
<p style="text-align: center;"><b>Independent from the ambient conditions (e.g. fuel pressure and temperature) and independent from the used fuel the design of the fuel system must prevent from vapour lock conditions. Vapour lock may result in engine stoppage.</b></p>

	Interface Parameter	Min.	Max.
<b>Fuel inlet</b>	Fuel pressure (relative to MAP)	2.9 bar (42 psi)	3.2 bar (46 psi)
	Acceptable Fuel pressure exceedance (max. 3 sec.)	2.5 bar (36 psi)	3.5 bar (51 psi)
	<p><b>NOTE</b> <i>Fuel pressure exceedance only allowed after power setting change</i></p>		
	Fuel pressure oscillation (min. sample rate 20 kHz)	-	1.0 bar (14.5 psi), peak-to-peak
	Fuel flow	56 l/h (14.8 gal/h)	150 l/h (39.6 gal/h)
	Fuel quality	EN 228	-

**Fine filter quality** **NOTE**  
*Nominal rating 8 – 12 µm, minimum 82 % capture efficiency according to ISO 19438 (edition 11/2003), dirt particles > 35 µm are not permissible.*

**Connection:** M14x1.5 or AN-6 (9/16-18 UNF).

	Interface Parameter	Min.	Max.
<b>Fuel outlet</b>	Fuel pressure (relative to Fuel Tank pressure)	-	0.5 bar (7.3 psi)

**Connection:** M14x1.5 or AN-6 (9/16-18 UNF).

### ELECTRICAL INTERFACES – 916 I TYPE A

	Interface Parameter	Min.	Max.	Nominal
<b>Fuel pump connectors</b>	Output Voltage (V)	12 V	14.5 V	13.8 V
	Output Current (A)	Fuel pump assy. (both pumps):		
		7 A	10.5 A	–
	Output Current (A)	Single pump:		
		4.5 A	7.5 A	–

# BRP-Rotax INSTALLATION MANUAL

## ELECTRICAL INTERFACES – 916 I TYPE C24

Fuel pump  
connectors

916 i TYPE C 24

Interface Parameter	Min.	Max.	Nominal
Output Voltage (V)	12 V	14.5 V	13.8 V
Output Current (A)	Fuel pump assy. (both pumps): @ 12 V = 9.1 A [+/- 2 A]		
	Single pump: @ 12 V = 5 A [+ 2.5 A / - 0.5 A]		

Cockpit Air-  
frame side

Connector	PIN	Function	Type
X4	A	14 V (for EMS, Battery Backup)	Output
	B	14 V GND (for EMS, Battery Backup)	Output
	C	14 V (for Fuel Pump 2 / Aux.)	Output
	D	14 V GND (for Fuel Pump 2 / Aux)	Output

## MECHANICAL INTERFACES

Adapter for fuel  
pressure

Standard banjo bolt can be replaced by an optional Sensor adapter for connectivity directly on the fuel inlet of the fuel pressure regulator. See SI-PAC-024.

Interface Parameter	Min.	Max.
Tightening torque	23 Nm (17 ft. lb)	27 Nm (20 ft.lb)
Component mass (adapter with sensor)	-	80 g

**Connection:** M12 x 1.5

**BRP-Rotax**  
INSTALLATION MANUAL

**INSTALLATION NOTES**

**General**

The representation of components in this chapter which are not within scope of the delivery is only symbolic. The design shown in this chapter does not represent a specified execution but should support the understanding of the system.

The final design, the selection and specification of parts according to the respective applicable regulations, the consideration of the system limitations and interface description as well as the comprehension of the operating limits in every operational state is in the responsibility of the aircraft manufacturer.

The aircraft manufacturer has to make sure that the operating limits given in the Operators Manual (OM) can be supervised by the pilot. The execution of the installation must allow the operation of the engine according to the Operators Manual (OM).

# BRP-Rotax INSTALLATION MANUAL

## INSTALLATION OVERVIEW

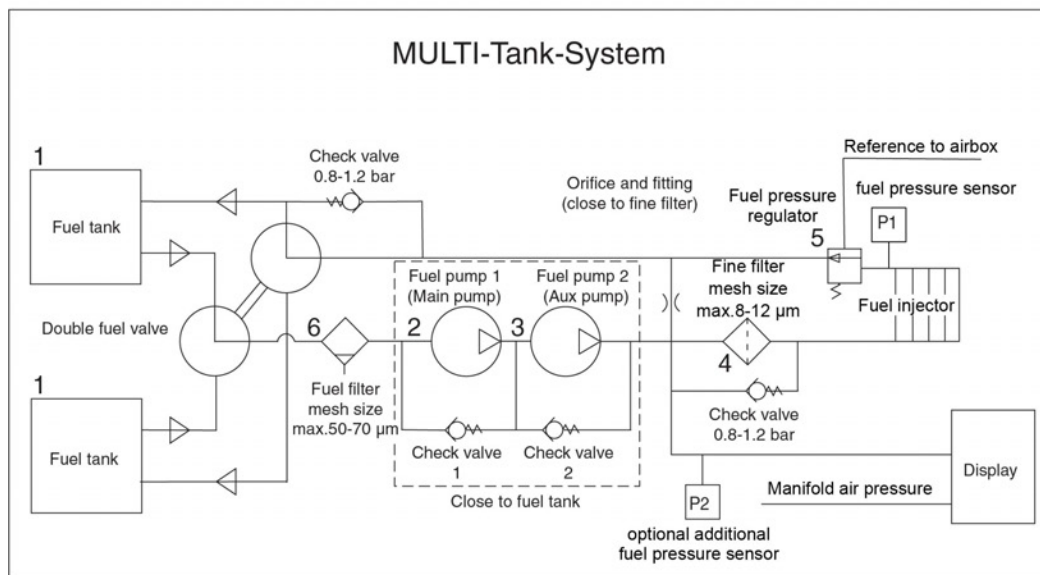
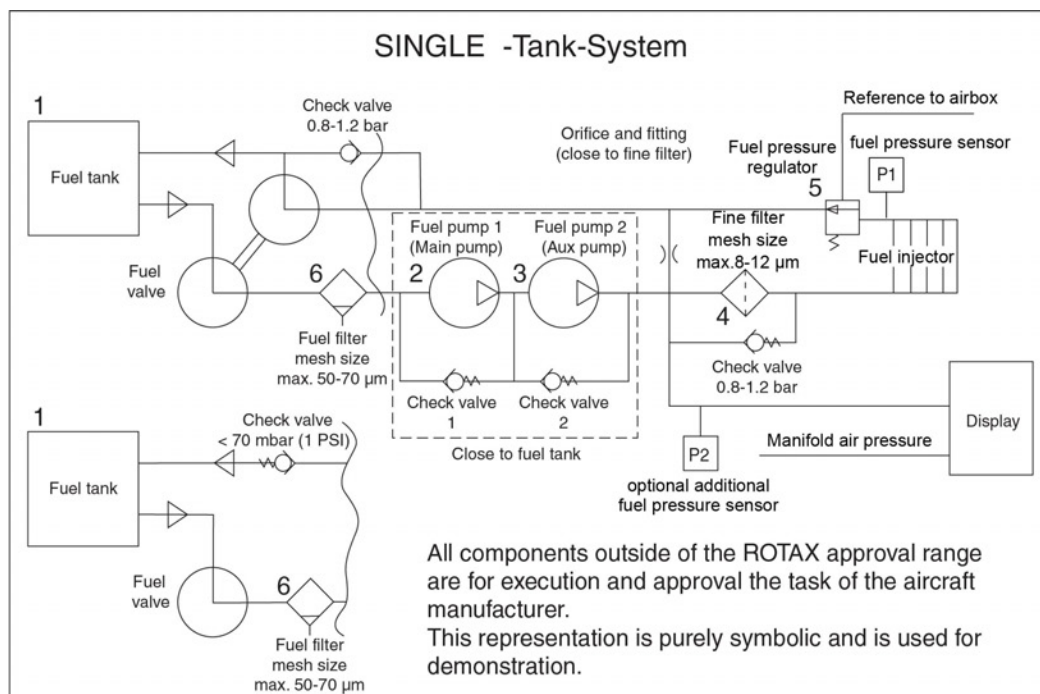

AE5IS\_0783\_a

Figure 7.4: Fuel system

- |                           |                            |
|---------------------------|----------------------------|
| 1 Fuel tank               | 2 Fuel pump 1              |
| 3 Fuel pump 2             | 4 Fine filter              |
| 5 Fuel pressure regulator | 6 Coarse filter/water trap |

# BRP-Rotax INSTALLATION MANUAL

## FUEL LINES

To prevent problems with vapour lock, all the fuel lines should be insulated against heat in the engine compartment. It is recommended to route the fuel lines in an appropriate distance from hot engine components and avoid sharp bends.

For a better heat dissipation it is recommended to use fuel lines made of metal whenever practicable (except for flex hoses to/ from engine).

Fuel lines should be installed by using suitable screw clamps or by ferrules.

Non drainable low points in feed, return and vent lines should be avoided. Any low points should allow for drainage of water and other contaminants.

### ⚠ WARNING

**Non-compliance can result in serious injuries or death!**

At the low points, accumulations of water can freeze and cut of the fuel flow.

## INLET LINE

The inlet line should have an inner diameter of at least 7.5 mm (0.3 in). (AN-6 or 3/8").

### NOTICE

Fuel lines smaller than this diameter may have a significant impact on the proper functionality of this engine.

## RETURN LINE

The return line should have a inner diameter of at least 7.5 mm (0.3 in). (AN-6 or 3/8").

### NOTICE

Fuel lines smaller than this diameter may have a significant impact on the proper functionality of this engine.

Vapour locks in the return line should be efficiently vented out of the fuel system to the atmosphere. Adequate fuel tank venting system design is imperative. Large vent lines with (most) direct routing avoiding low points are desired.

## BYPASS LINE

To allow venting of the fuel system and better fuel pump engagement after a potential inclusion of air, there could be installed a restricted bypass line between the inlet (pressure side of the fuel pump module) and the return line. In this bypass line a restricted jet should be installed so that there is an ideal balance between short venting time and minimum fuel flow rate. The positioning and dimensioning of the jet is up to the aircraft manufacturer.

If no bypass line is installed, the pressure release in the fuel lines is very slow. This should be noted accordingly in the manuals of the aircraft manufacturer (fuel lines are possibly under full operating pressure even after engine stop).

# BRP-Rotax INSTALLATION MANUAL

## NOTE

*The switching between several fuel tanks at power loss due to fuel shortage should be given within a defined period of time and without falling below the minimum performance limit and must be ensured by the aircraft manufacturer. Refer to the latest requirements such as FAR or EASA.*

## COARSE FILTER

The coarse filter should be installed at an easy accessible position to allow a periodic inspection.

Following fuel filter could be used to ensure that the engine is supplied with fuel of an adequate quality:

Interface Parameter	Min.	Max.
Filter mesh size	50 micron (0.0019 in.)	70 micron (0.0028 in.)
Filter surface (total)	64.4 cm <sup>2</sup> (10 in <sup>2</sup> )	-
Passing area	18.4 cm <sup>2</sup> (2.85 in <sup>2</sup> )	-

The filter should be installed in the supply line between the tank and the fuel pumps and should be of sufficient capacity to prevent complete blockage between maintenance intervals.

### NOTICE

An installation without coarse filter may have a significant impact on the proper functionality of this engine.

## WATER TRAP, GASCOLATOR

A suitable water trap must be installed. Certification according to the latest regulations, such as FAR or EASA, must be conducted by the aircraft or fuselage manufacturer.

## FINE FILTER

The fine filter should be installed at an easy accessible position to allow a periodic inspection. To ensure that the engine is supplied with fuel of an adequate quality, a fine filter with following specifications should be installed between the fuel pumps (module) and the injection rail (Cylinder 1/3):

Interface Parameter	Min.	Max.
Filter mesh size	8 micron	12 micron
Fuel flow rate	90 l/h (23.8 gal/h)	-
Differential pressure		0.02 bar (0.29 psi)

# BRP-Rotax INSTALLATION MANUAL

## NOTICE

An installation without fine filter may have a significant impact on the proper functionality of this engine.

## FUEL PUMP

For reducing the risk of vapor lock, the fuel pump should be placed in a well-ventilated area. A recommended installation position would be near the fuel tank in order to ensure a safe fuel supply.

## FUEL PRESSURE SENSOR

The operating limit of the fuel pressure should be observed at the inlet of the fuel pressure regulator.

An additional fuel pressure sensor could be placed before the fine filter, so the filter load can be checked. An increase of fuel pressure over the allowed limit could mean that the fine filter is becoming contaminated. The fine filter should be checked and replaced if necessary.

## FUEL PRESSURE REGULATOR

Fuel pressure regulators have very precise tolerances and are generally reliable. Mostly pressure fluctuations are not caused by the pressure regulator, they might be found in other sections (filter clogged, pulsation of lines, kinks in the hoses etc.) of the fuel system.

## FUEL TANK

In case of supply problems of the fuel pump, the fuel tank should be emptied and filled with AVGAS. If the problem does not occur at the next test (with AVGAS), then this is a sign of formation of vapour locks when using MOGAS (or auto fuel).

Following points may have a positive impact on the proper functionality of this engine:

- Single tank (large volume of fuel in the tank, just a few fuel lines)
- Catch tanks in the wing tanks. This provides the fuel supply in every flight situation/ position
- Header tank (the following reference values should be considered):

Interface Parameter	Specification
Venting line	The venting line from header tank to wing tank should generally be on an incline to avoid trapping bubbles. The venting line must have an inner diameter of at least 12 mm (0.50 in).
Feed lines	Fuel feed lines from the wing tanks to the header tank should be on a steady decline.



# **BRP-Rotax**

## **INSTALLATION MANUAL**

Following points may have a negative impact on the proper functionality of the engine:

- A header tank design that enables the re-entry of vapour locks in the suction line
- Multi tank system without catch-, header tank

### **FUEL SHUT OFF VALVE**

The fuel shut off valve position on the pressure side of the fuel system (after the fuel pump module) can have an unfavorable impact on the installation of the engine.

**BRP-Rotax**  
INSTALLATION MANUAL

INTENTIONALLY LEFT  
BLANK

**BRP-Rotax**  
**INSTALLATION MANUAL**

**Chapter: 75-00-00**  
**COOLING SYSTEM**

**TOPICS IN THIS CHAPTER**

**System Description .....3**  
    System limitations .....3

**Interface description .....4**  
    Interface overview .....4  
    Hydraulic interfaces .....5  
    Air Cooling interfaces .....7

**Installation notes .....10**  
    Installation overview .....10  
    Water inlet elbow .....12  
    Expansion tank .....12  
    Coolant hoses .....13  
    Coolant .....13

**Validation of installation .....14**

**BRP-Rotax**  
**INSTALLATION MANUAL**

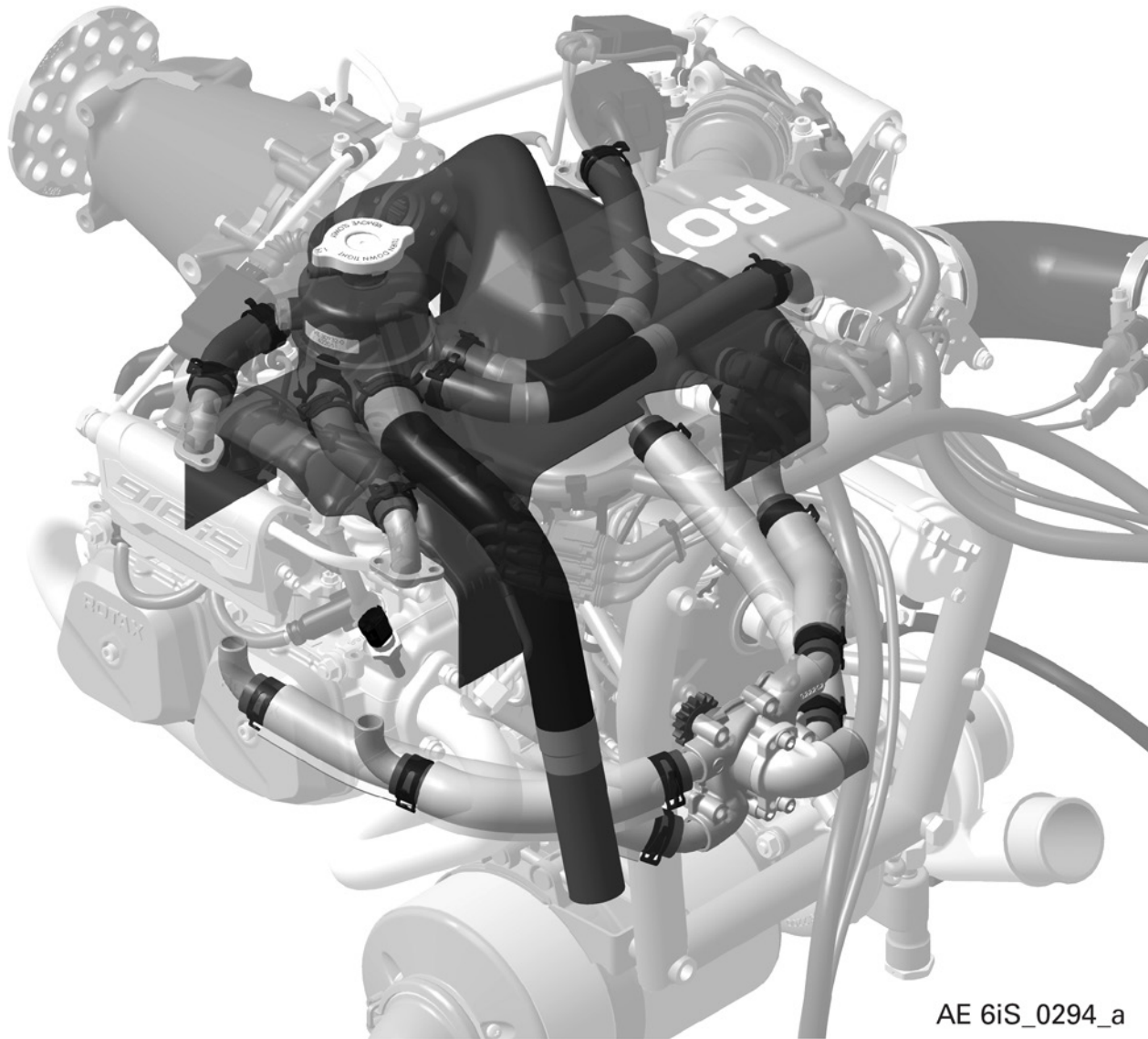

Figure 8.1: Cooling System

# BRP-Rotax INSTALLATION MANUAL

## **SYSTEM DESCRIPTION**

For a detailed System description refer to the latest issue of the Operators Manual (OM).

### **SYSTEM LIMITATIONS**

**Operating limits** Refer to latest issue of the Operators Manual (OM).

#### **⚠ WARNING**

##### **Non-compliance can result in serious injuries or death!**

The cooling system must be designed so that operating temperatures will not exceed the maximum values.

**Coolant types** It is important that the coolant circuit is designed so that the coolant does not reach boiling point under any conditions. If the temperature exceeds the boiling point, the engine can quickly overheat due loss of coolant.

The boiling point of the coolant is mainly influenced by:

- the type of coolant
- mixture ratio (percentage water rate)
- the system pressure (opening pressure of radiator cap)

For permissible coolant types see SI-916i-001, latest issue.

**System pressure**

<b>System Limit</b>	<b>Min.</b>	<b>Max.</b>
Coolant system pressure	–	1.2 bar (18 psi)

**Hose connecting expansion tank to overflow bottle**

<b>System Limit</b>	<b>Min.</b>	<b>Max.</b>
Able to withstand heat and vacuum without collapsing-able	125 °C (257 °F)	–

A soft walled hose is not suitable as it can collapse and cause cooling system failure.

**Expansion tank**

To ensure proper operation of the cooling system, the expansion tank with pressure cap in the main operating systems must be installed on the highest point of the cooling circuit.

**BRP-Rotax**  
**INSTALLATION MANUAL**

**INTERFACE DESCRIPTION**

**INTERFACE OVERVIEW**

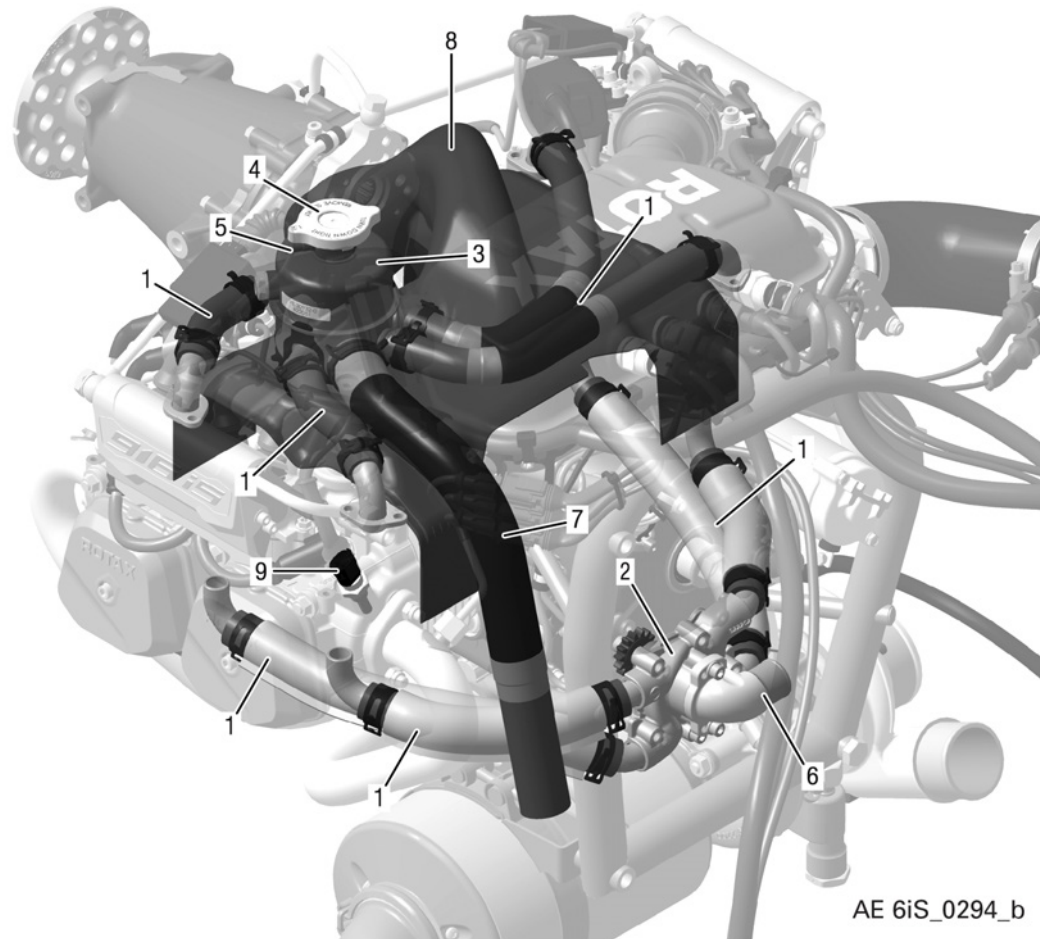

Figure 8.2: Cooling System – Interfaces

- |   |   |   |   |
|---|---|---|---|
| 1 | Coolant hose                                    | 2 | Water pump housing                      |
| 3 | Expansion tank assy.                            | 4 | Radiator cap                            |
| 5 | Expansion tank connection (hydraulic Interface) | 6 | Water inlet elbow (hydraulic Interface) |
| 7 | Water outlet (hydraulic Interface)              | 8 | Coolant Temperature Sensor (CTS)        |
| 9 | Cooling air baffle                              |   |   |

# BRP-Rotax INSTALLATION MANUAL

## HYDRAULIC INTERFACES

### Water inlet elbow

Interface Parameter	Min.	Max.
Cooling system pressure (relative)	1.6 bar (232 psi)	-
Cooling water temperature	- 20 °C (- 4 °F)	125 °C (257 °F)
Cooling water flow (at 5800 rpm)	70 l/h (18.49 USgal/ min)	-
Slip on length	19 mm (0.75 in)	

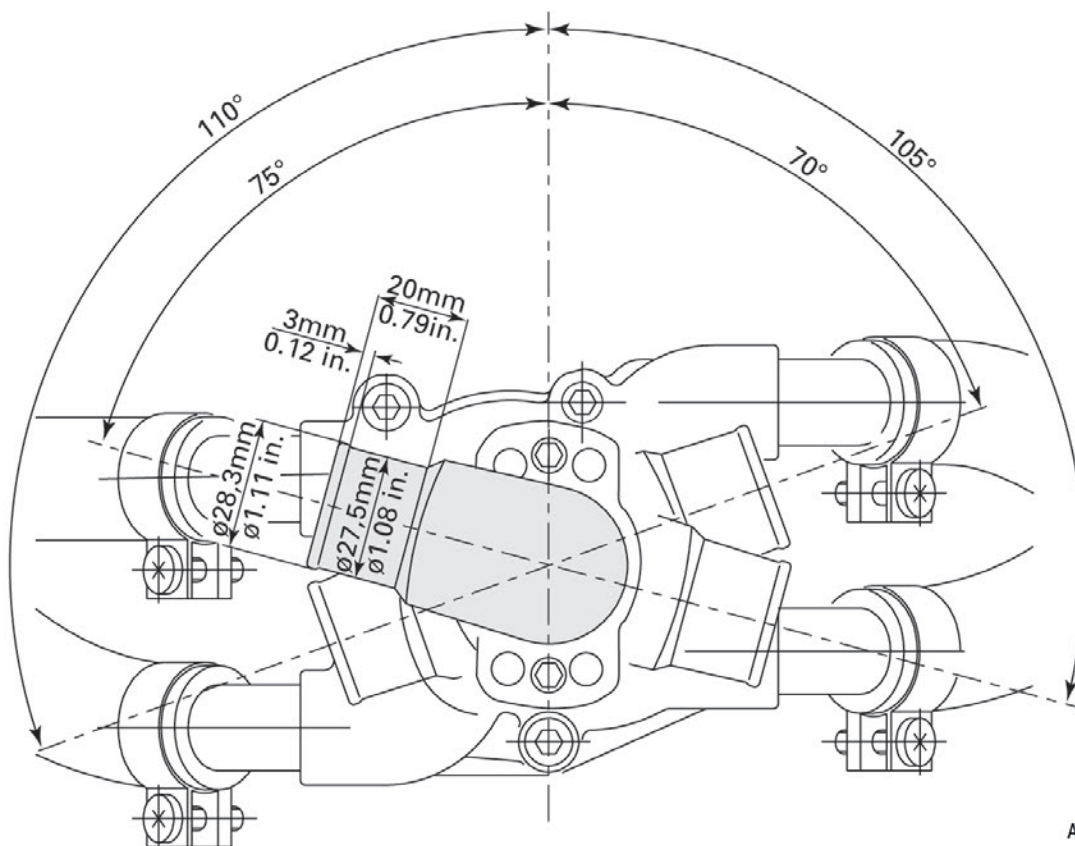

AE 5IS\_0375

Figure 8.3: Water inlet elbow

**Connection:** Outer diameter 27 mm (1.07 in).

### Water outlet

Interface Parameter	Min.	Max.
Cooling system pressure (relative)	1.6 bar (232 psi)	-
Cooling water temperature	- 20 °C (- 4 °F)	130 °C (266 °F)
Cooling water flow (at 5800 rpm)	70 l/h (18.49 USgal/ min)	-

# BRP-Rotax INSTALLATION MANUAL

**Connection:** Inner diameter 25 mm (0.98 in).

## Expansion tank connection

Interface Parameter	Min.	Max.
Slip on length	18 mm (0.71 in.)	

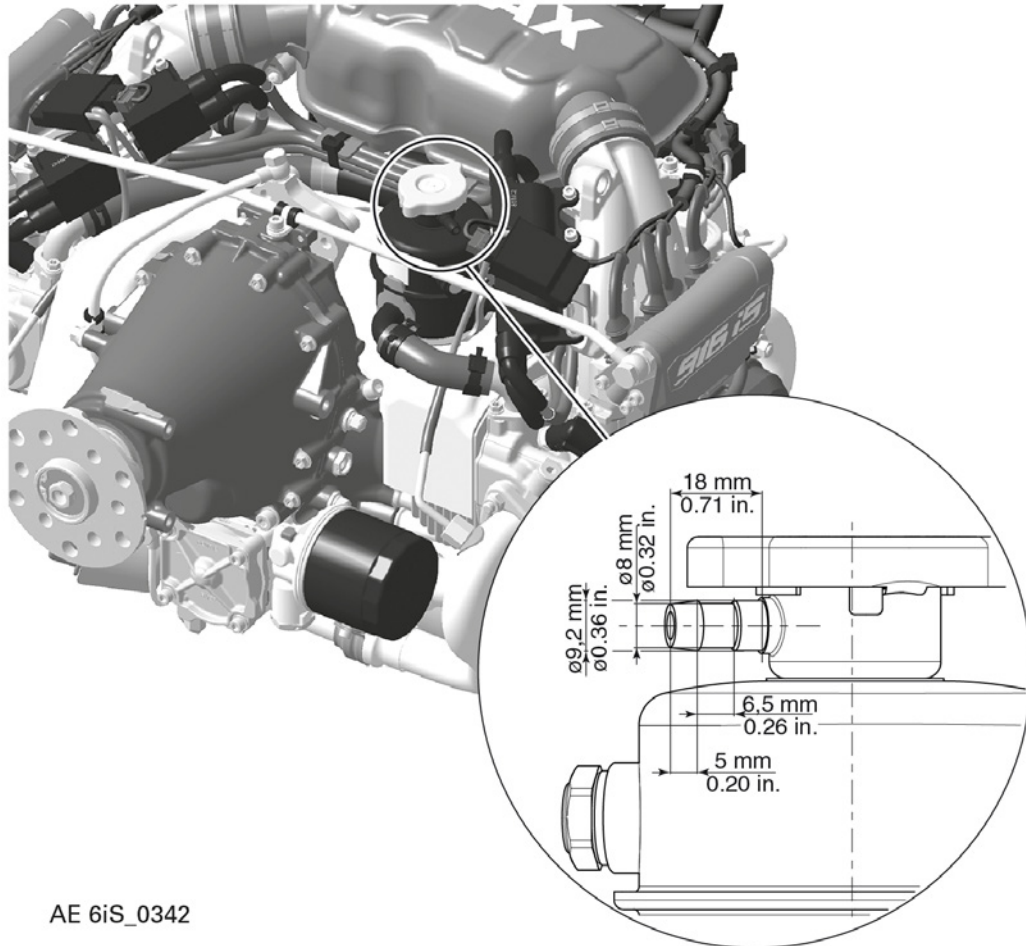

Figure 8.4: Expansion tank connection



# BRP-Rotax INSTALLATION MANUAL

## AIR COOLING INTERFACES

### Cooling air baffle

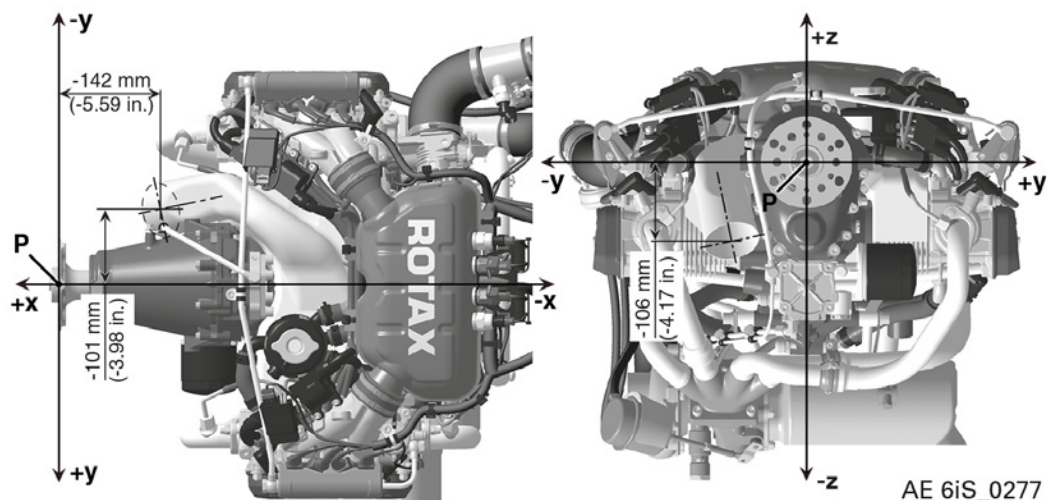

Figure 8.5: Cooling air baffle position, TYPICAL

Position	x-axis	y-axis	z-axis
P1	- 142 mm (- 5.59 in.)	- 101 mm (- 3.98 in.)	- 106 mm (- 4.17 in.)

### General information

#### NOTE

*In some special cases a separate cold air supply to the air baffle should be provided.*

### Cylinder wall temperature

Max. permitted cylinder wall temperature on hottest cylinder is 200 °C (392 °F). See the following figure. The cylinder wall temperature can be measured using a thermocouple.

#### NOTE

*If this temperature is exceeded, appropriate measures (e.g. cooling air ducts, modifications to cowling, etc.) must be taken to bring it within limits again.*

# BRP-Rotax INSTALLATION MANUAL

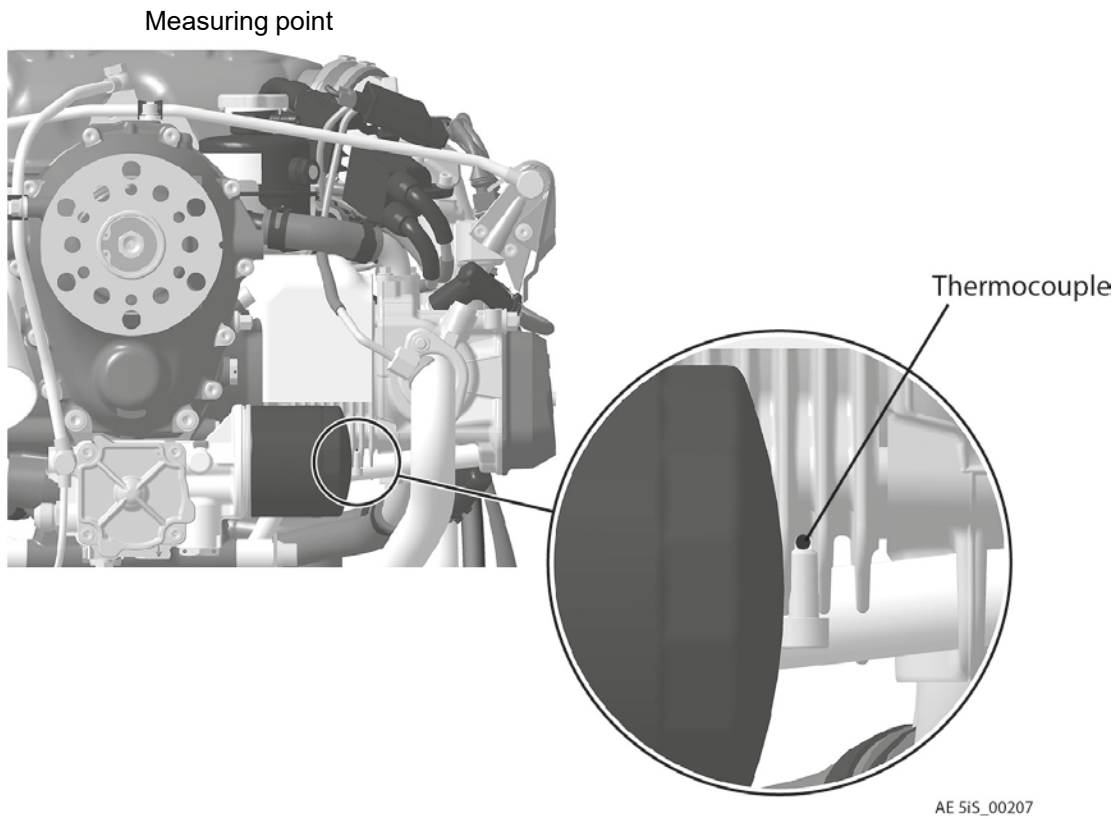
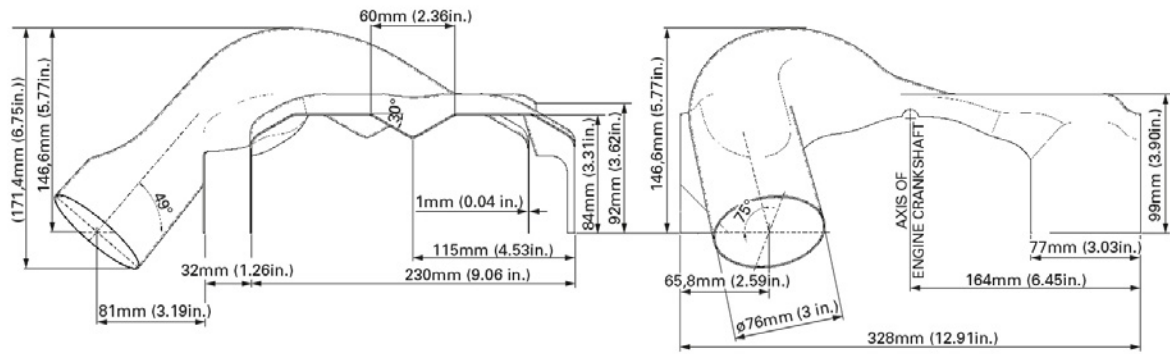

Figure 8.6: Measuring point TYPICAL

Following recommendations should assist the aircraft or fuselage manufacturer in selecting suitable cooling air ducts:

Specification	Description
Cooling capacity	The cooling air baffle must be designed so, that it transfers thermal energy of approx. 6 kW (5.7 BTU/s) at take-off performance.
Cross section of air baffle	Cross section of the air baffle min. 100 cm <sup>2</sup> (15.50 in <sup>2</sup> ).
Material	Glass fibre reinforced plastic or heat and fire resistant material.
Attachment options	Formlocking on engine block and mounting above the cylinder and the crankcase.

# BRP-Rotax INSTALLATION MANUAL



AE 6iS\_0348

Figure 8.7: Dimensions of cooling air baffle

# BRP-Rotax INSTALLATION MANUAL

## INSTALLATION NOTES

The representation of components in this chapter which are not within scope of the delivery is only symbolic. The design shown in this chapter does not represent a specified execution but should support the understanding of the system.

The final design, the selection and specification of parts according to the respective applicable regulations, the consideration of the system limitations and interface description as well as the comprehension of the operating limits in every operational state is in the responsibility of the aircraft manufacturer.

**The aircraft manufacturer has to make sure that the operating limits given in the Operators Manual (OM) can be supervised by the pilot. The execution of the installation must allow the operation of the engine according to the Operators Manual (OM).**

## INSTALLATION OVERVIEW

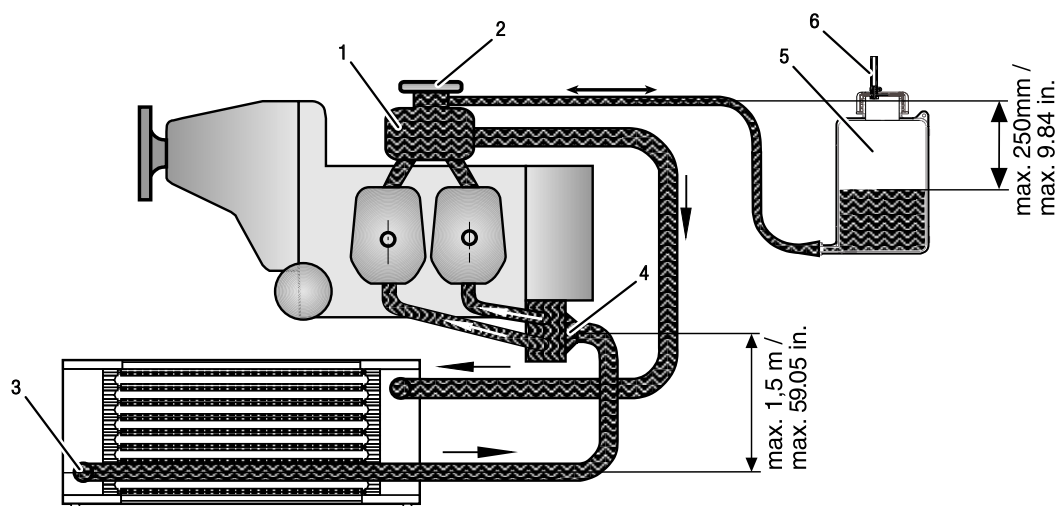

Figure 8.8: Cooling system schematic

- |                   |                |
|-------------------|----------------|
| 1 Expansion tank  | 2 Pressure cap |
| 3 Radiator        | 4 Water pump   |
| 5 Overflow bottle | 6 Vent         |

### Radiator

In an installation as depicted with the radiator in a higher position than the standard supplied expansion tank, a water accumulator has to be fitted instead of the expansion tank. Additionally a suitable expansion tank has to be installed at the highest point of the cooling circuit

In order to support the deployment of the radiator's full capacity, the radiator should be connected with the upper connection to the suction side in direction to the water pump. Otherwise, air bubbles may accumulate, resulting in reduced cooling capacity (see setup depicted in [Cooling system schematic](#)).

# BRP-Rotax INSTALLATION MANUAL

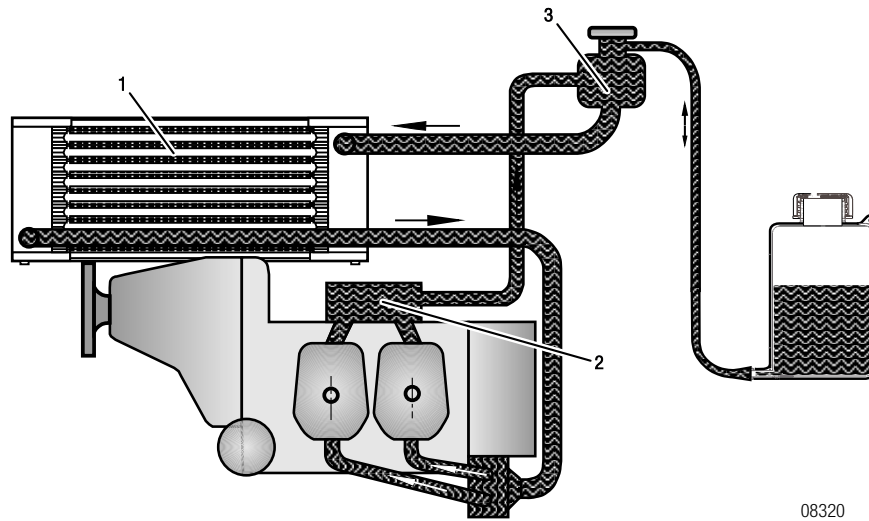

Figure 8.9: Radiator

- |   |                            |
|---|----------------------------|
| <p>1 Radiator</p> <p>3 Expansion tank</p> | <p>2 Water distributor</p> |
|---|----------------------------|

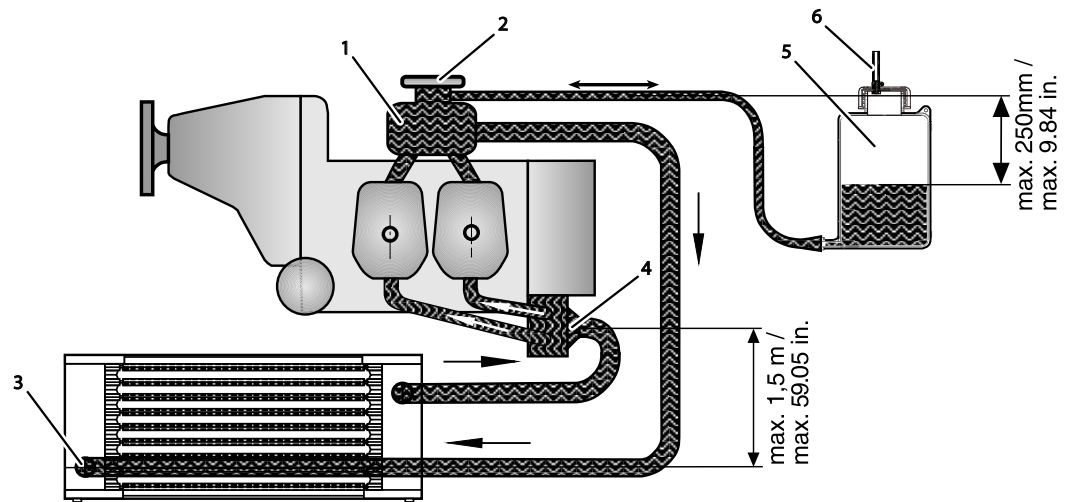

Figure 8.10: Cooling system schematic

- |  |   |
|--|---|
| <p>1 Expansion tank</p> <p>3 Radiator</p> <p>5 Overflow bottle</p> | <p>2 Pressure cap</p> <p>4 Water pump</p> <p>6 Vent</p> |
|--|---|

# BRP-Rotax INSTALLATION MANUAL

## WATER INLET ELBOW

### NOTICE

The hoses should be fixed with appropriate clips to prevent loss e.g. with spring type hose clips, such as those used for the coolant hoses between the water pump and cylinder.

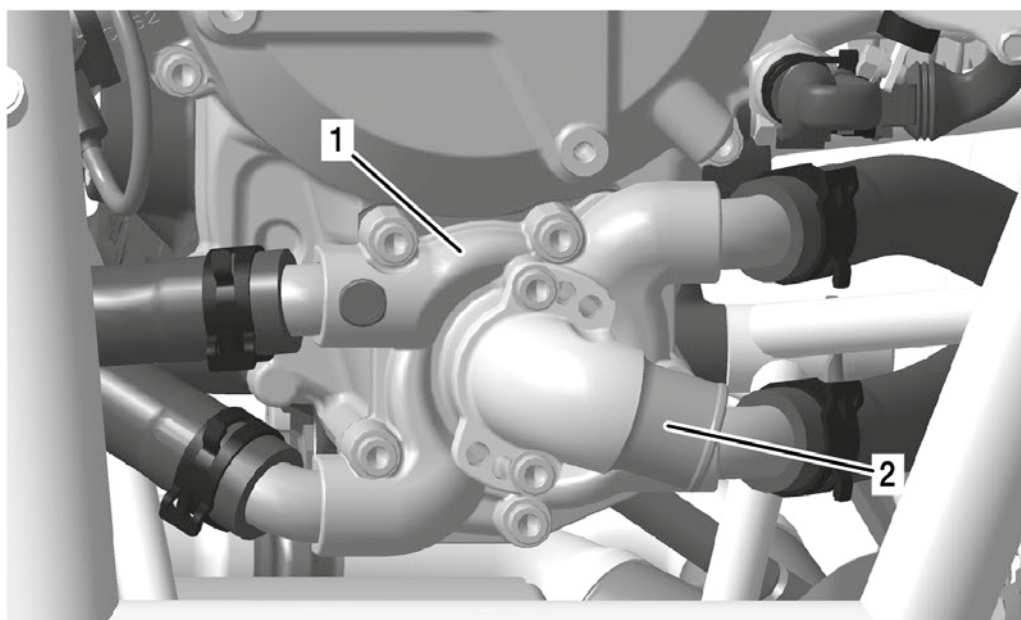

AE 51S\_0377

Figure 8.11: Water inlet elbow

1 Water pump housing

2 Water inlet elbow

Use two M6x20 Allen screws lock washers to attach the water inlet elbow. Tighten screws to 10 Nm (89 in lb.)

### NOTICE

The total slip-on length of the water inlet elbow and expansion tank should be used.

## EXPANSION TANK

The aircraft manufacturer should give the possibility to the pilots to check the coolant level in the expansion tank. It is also necessary to inform the pilots about the daily inspection of the coolant level in the aircraft manufacturers Operators Manual (OM).

To allow this inspection, e.g. a flap or panel on the cowling or a warning instrument in the cockpit for low coolant level should be installed.

# BRP-Rotax INSTALLATION MANUAL

## COOLANT HOSES

### NOTE

*For proper operation short hoses should be used.*

Aluminium tubes with an inner diameter of 25 mm (0.98 in) can be used instead of longer hoses. These should have a bulge (1) in order to prevent coolant hoses working loose.

Note as well that this will double the number of hose clips required.

The material of the hoses must be resistant against glycol, coolant and ozone.

Interface Parameter	Min.	Max.
Temperature resistance	125 °C (257 °F)	
Pressure durability	5 bar (72 psi)	
Inner diameter	25 mm (1")	
Bending radius	175 mm (6.89 in)	

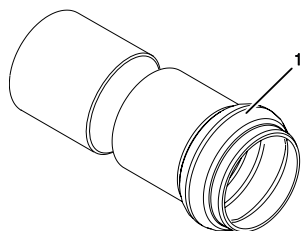

09158

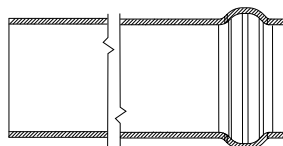

Figure 8.12: Aluminium tube

### Hoses

Hoses exposed to direct heat radiation from exhaust system must be suitably protected with e.g. heat resistant protection tubes.

The hose between the overflow bottle and the expansion tank should be as short as possible.

## COOLANT

### NOTICE

**Use only coolant as recommended in the current Operators Manual (OM) and SI-916 i-001 "Selection of suitable operation fluids", current issue.**

# BRP-Rotax INSTALLATION MANUAL

## VALIDATION OF INSTALLATION

### General

The validation procedures described in this chapter do not claim to be complete. The correct execution and compliance with all given system limitations and interface descriptions as well as with standards and norms given by authorities must be proven by the aircraft manufacturer.

### Coolant temperature

The maximum coolant temperature must be determined in order to check the efficiency of the cooling system.

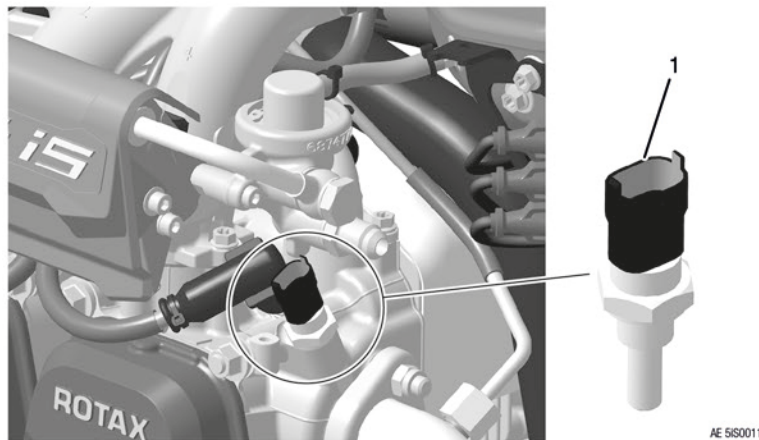

Figure 8.13: Coolant Temperature Sensor (CTS), TYPICAL

1 Coolant temperature sensor

The coolant temperature is measured using a temperature sensor (1), which is installed on cylinder 4.

### NOTICE

**It is possible to record a false measurement when measuring fluid temperatures. If fluid volume is lost and sensor is not fully submerged in the liquid, the indicating instrument could incorrectly display a lower temperature, by measuring the air temperature instead of the coolant temperature.**

### Pressure test

To ensure the System has no leakage, remove the pressure cap from the expansion tank. Then attach the pressure tester and pump the system until the pressure manometer shows 1.2 bar (18 psi). After min. 1 minute, there should be still 1.2 bar (18 psi) pressure in the system.

- Check the efficiency of the coolant radiator and its proper sealing between cowling and radiator.
- Check the proper flow between expansion tank and overflow bottle.
- Ensure that no ram-air is induced onto the overflow bottle vent line.
- Check efficiency of air duct and proper air flow through the duct and around cylinders.



## **BRP-Rotax**

### **INSTALLATION MANUAL**

- Consider cold (winter) and hot (summer) conditions in ground and flight testing.
- Check proper dampening of the water radiator and stressfree installation and proper sealing.

**BRP-Rotax**  
INSTALLATION MANUAL

INTENTIONALLY LEFT  
BLANK

**BRP-Rotax**  
**INSTALLATION MANUAL**

**Chapter: 76-00-00**  
**ENGINE CONTROLS**

**TOPICS IN THIS CHAPTER**

<b>Special tools</b> .....	<b>4</b>
<b>System description</b> .....	<b>5</b>
System limitations .....	5
<b>Interface description</b> .....	<b>6</b>
Interface overview .....	6
Electrical interfaces .....	7
Interface overview — 916 I Type C24 .....	10
Electrical interfaces – 916 I Type C24 .....	11
Mechanical interfaces .....	14
<b>Installation notes</b> .....	<b>16</b>
Installation overview .....	16
Installation overview – 916 I Type C24 .....	18
LANE Select Switches .....	20
Start Switch .....	20

# BRP-Rotax INSTALLATION MANUAL

916 i TYPE A

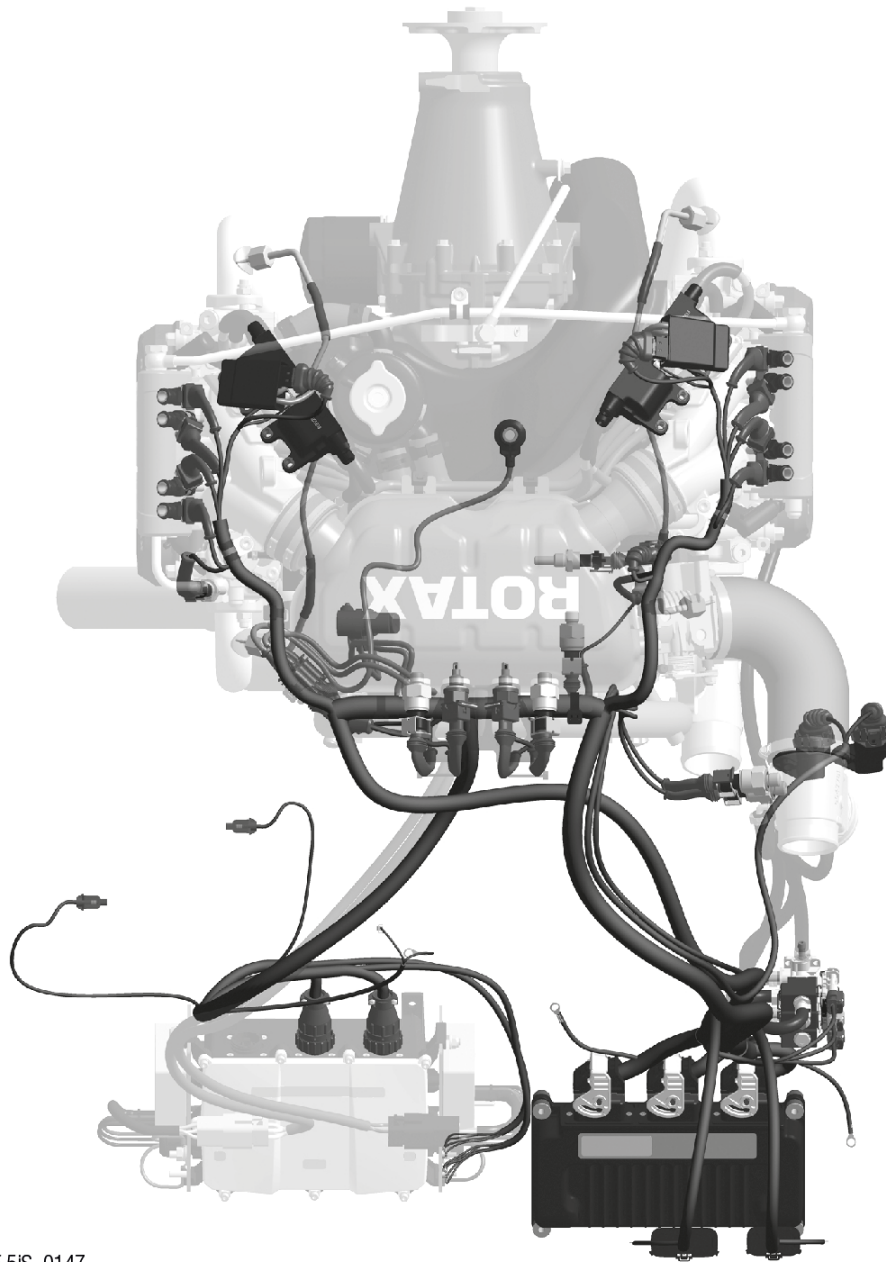

AE 5iS\_0147

Figure 9.1: Engine management system (EMS), TYPICAL

# BRP-Rotax INSTALLATION MANUAL

916 i TYPE C24

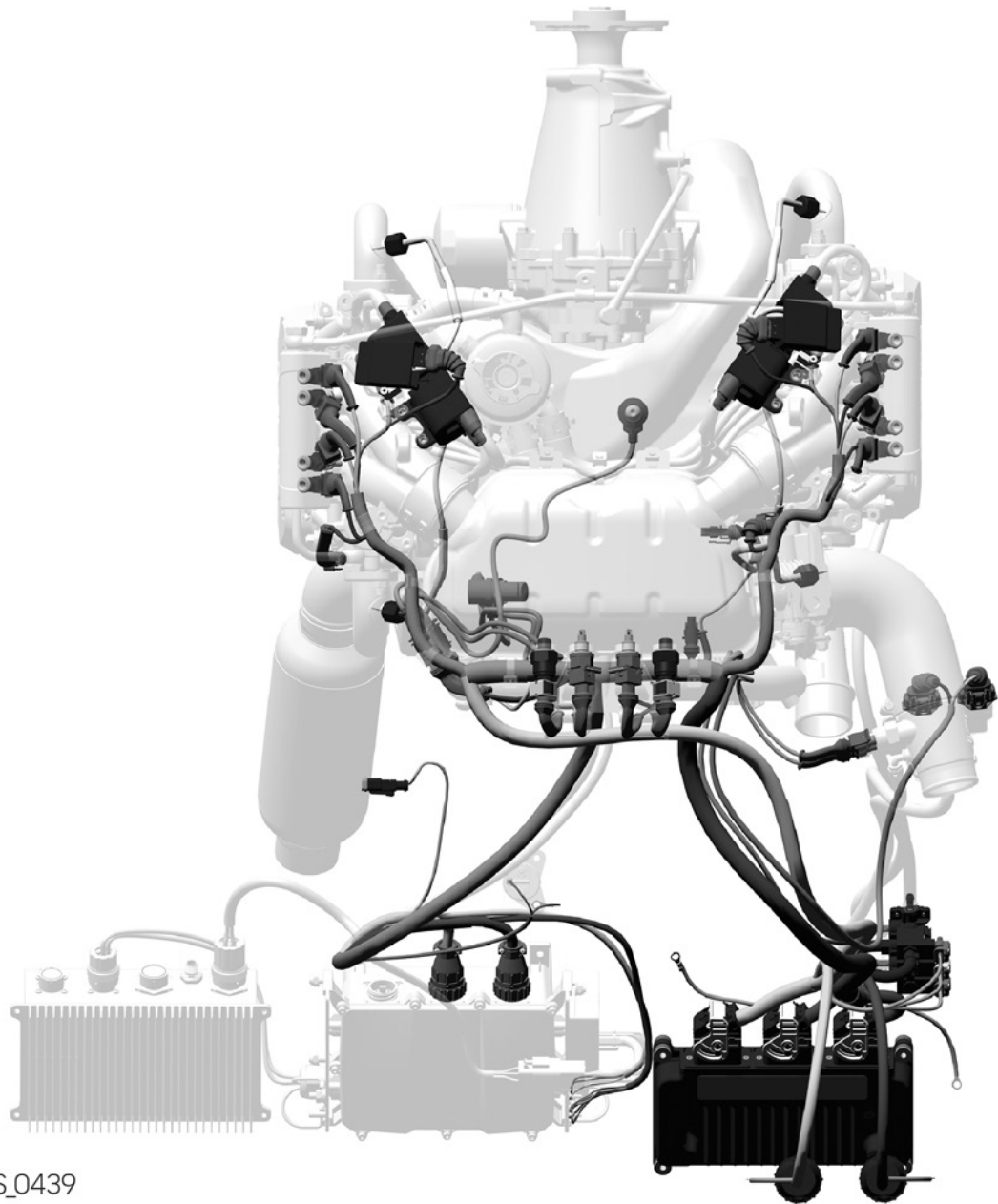

AE\_6iS\_0439

Figure 9.2: Engine management system (EMS), TYPICAL

**BRP-Rotax**  
**INSTALLATION MANUAL**

**SPECIAL TOOLS**

Description	Part number
Crimping pliers MOLEX 64016-0035/63811-4400	n.a.
Disassembly tool MOLEX 63813-1500	n.a.
Crimp tool ROTAX® ACDC 28 V X1/X2 and 14 V X1 - SKU: 10-306 <sup>3</sup>	n.a.
Crimp tool ROTAX® ACDC 28 V X3/X4 - SKU: 10-309 <sup>3</sup>	n.a.
Crimp tool ROTAX® ACDC 28 V X5 and 14 V X3 - SKU: 10-311 <sup>3</sup>	n.a.

3. can be ordered under [www.rs-flight systems.com](http://www.rs-flight systems.com)

# BRP-Rotax INSTALLATION MANUAL

## **SYSTEM DESCRIPTION**

For a detailed System description refer to the latest issue of the Operators Manual (OM).

### **SYSTEM LIMITATIONS**

- Operating limits** Refer to latest issue of the Operators Manual (OM).
- Valid installation positions** The ECU may be installed either in the engine compartment or in the cockpit. To prevent the ingress of liquids (moisture), the ECU must be mounted in a way that the plugs are facing downward.
- The two Ambient Air Pressure and Temperature Sensors (AAPTS) are all-in-one sensors for engine ambient temperature and engine ambient pressure. In cowled engine installations they have to be mounted in the engine compartment in a ram air free area and close to the air inlet. The sensors must measure the correct air inlet temperature and the air pressure right before the air filter. The AAPTS sensors must not be mounted in the air intake system between the air filter and turbocharger inlet. The AAPTS must be mounted isolated from vibrations (e.g. caused by the engine).
- The casing of the ECU must not be connected to the airframe ground. The rubber vibration damping (insulation material) must not be removed. If the rubber dampers were removed, the engine ground and the aircraft ground would be short-circuited..
- Component temperatures limitation** Limitation see Chapter 00-00-00 Approval of electric and electronic components.
- Connections** When connecting the wiring harness with the ECU take into account the labeling on the wiring harness and the ECU. Although the connectors are mechanically coded (i.e. wiring harness connector A1 can only be connected to ECU A1 socket), excessive force or incorrect positioning can result in bent pins and the ECU would then need to be replaced. Unplug the ECU connector from the wiring harness only if absolutely necessary. Connector plugs (ECU) are suitable for up to 20 plug-in operations. The number of plugging operations must be entered into the logbook. If this limit has been exceeded the ECU needs to be replaced.
- Wiring harness** In no case the wiring harness must be shortened or modified. Do not bend, kink, pinch or otherwise improperly stress the wiring harness. The bending radius of the wiring harness must not be less than 50 mm (1.97 in). To avoid excessive tension on the ECU connectors, a strain relief must be installed in a distance of ~ 100 mm (3.94 in) from the ECU.

#### **NOTICE**

**Do not bend, kink, pinch or otherwise improperly stress the wiring harness. Use proper routing, clamping and strain relief on wiring harnesses.**

**BRP-Rotax**  
**INSTALLATION MANUAL**

**INTERFACE DESCRIPTION**

**INTERFACE OVERVIEW**

916 i TYPE A

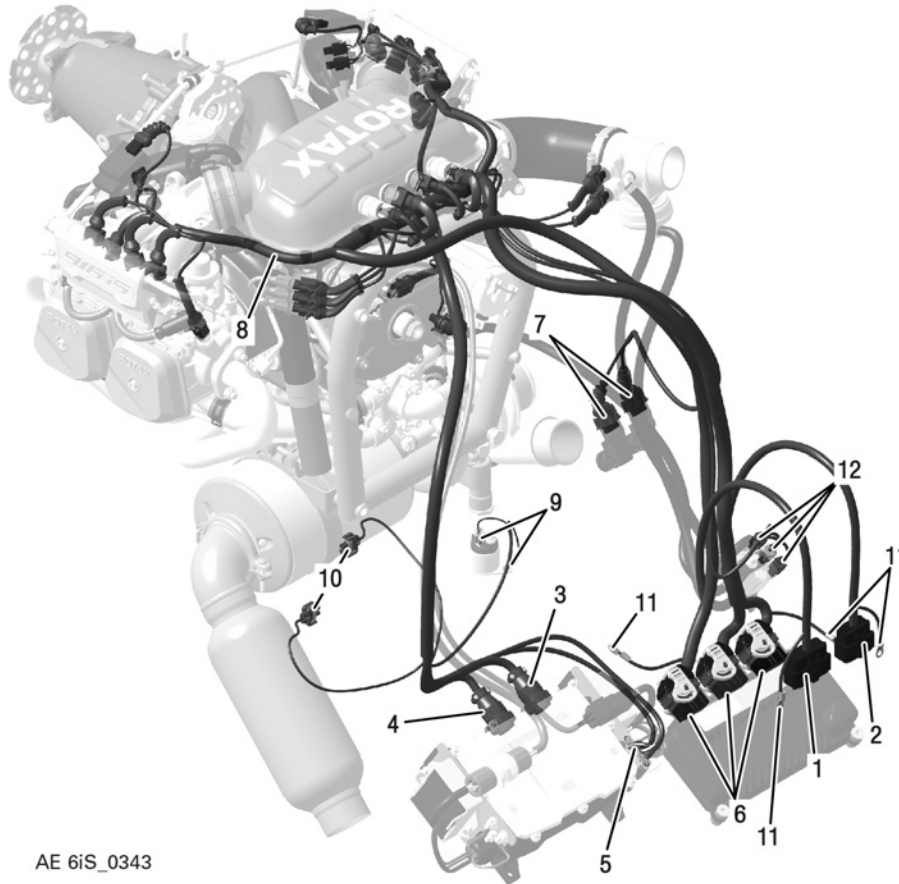

AE 6iS\_0343

Figure 9.3: Engine Management System (EMS) – Interfaces

- |    |   |    |   |
|----|---|----|---|
| 1  | <i>Harness Interface Connector A (HIC A)<br/>(electrical interface)</i> | 2  | <i>Harness Interface Connector B (HIC B)<br/>(electrical interface)</i> |
| 3  | <i>X1 Connector (electrical interface)</i>                              | 4  | <i>X2 Connector (electrical interface)</i>                              |
| 5  | <i>Regulator A (electrical interface)</i>                               | 6  | <i>ECU (electrical, mechanical interface)</i>                           |
| 7  | <i>AAPTS (electrical, mechanical<br/>interface)</i>                     | 8  | <i>Wiring harness</i>   |
| 9  | <i>Starter relay connectors (electrical<br/>interface)</i>              | 10 | <i>Fuel pump connectors (electrical<br/>interface)</i>                  |
| 11 | <i>Wiring harness grounding</i>   | 12 | <i>PCV Connector</i>  |



# BRP-Rotax INSTALLATION MANUAL

## ELECTRICAL INTERFACES

**Harness interface connector A** The HIC A connector allows powering ECU Lane A and Fuel Pump A. interfaces to Indication elements are described in Chapter 77-00-00.

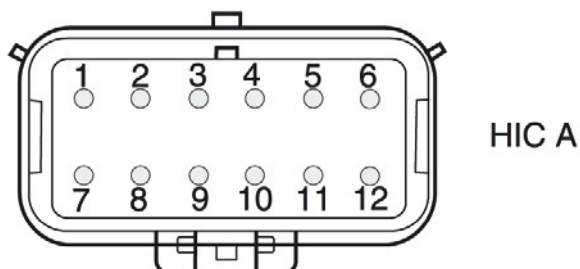

AE 5iS\_0186

Figure 9.4: HIC A Connector

In case the EMS is powered by an external power source or by one of the internal generators:

- A connection between Terminal 1 and Terminal 7 will power ECU Lane A
- A connection between Terminal 3 and Terminal 9 will power Fuel pump 1

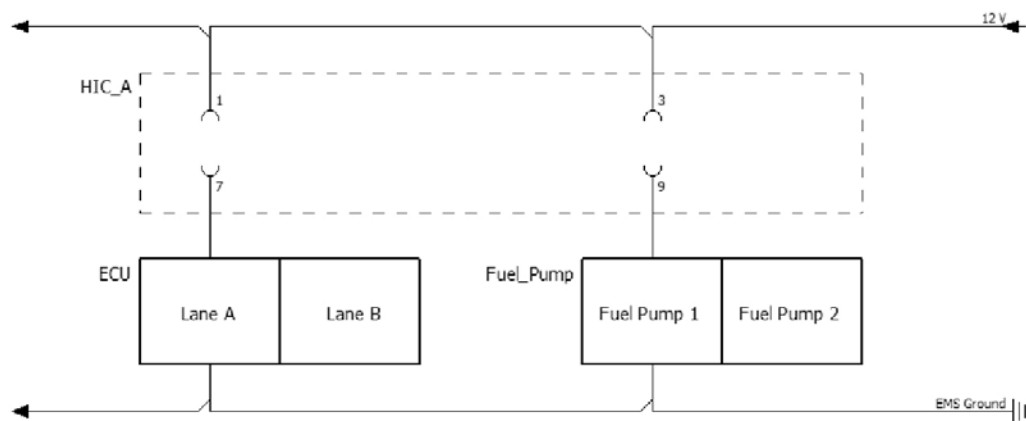

AE 5iS\_0188

Figure 9.5: HIC A connector –Engine controls

# BRP-Rotax INSTALLATION MANUAL

Terminal (Supply)		Terminal (Ground)		Interface Parameter	Min.	Max.	Nominal
1	LANE_SEL_SW_A_1	7	LANE_SEL_SW_A_2	Nominal Voltage			12 V
				Nominal Current		7.5 A	
3	SIG_FUEL_PUMP_1	9	GND_FUEL_PUMP_1	Nominal Voltage			12 V
				Nominal Current		10 A	

## Harness Interface Connector B

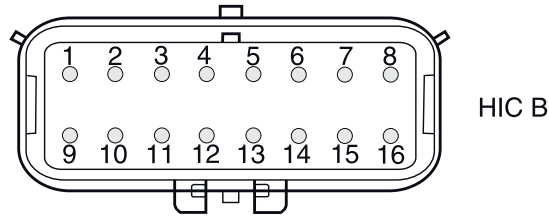

AE 5IS\_0187

Figure 9.6: HIC B connector

In case the EMS is powered by an external power source or by one of the internal generators:

- A connection between Terminal 1 and Terminal 9 will power ECU Lane B
- A connection between Terminal 3 and Terminal 11 will power Fuel Pump 2
- A connection between Terminal 4 and Terminal 12 will actuate the Starter Relay

# BRP-Rotax INSTALLATION MANUAL

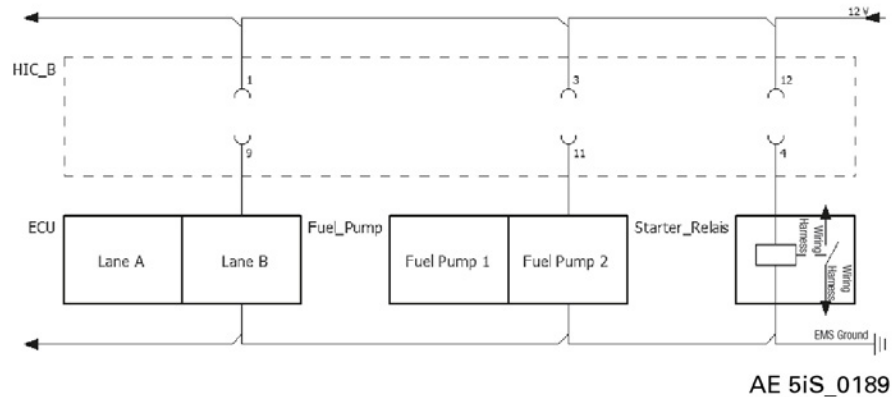

Figure 9.7: HIC B Connector – Engine controls

Terminal (Supply)		Terminal (Ground)		Interface Parameter	Min.	Max.	Nominal
1	LANE_SEL_SW_B_1	9	LANE_SEL_SW_B_2	Nominal Voltage			12 V
				Nominal Current		7.5 A	
3	SIG_FUEL_PUMP_2	11	GND_FUEL_PUMP_2	Nominal Voltage			12 V
				Nominal Current		10 A	
12	SUPP_START_SWITCH	4	CONN_STARTER_REL_SW	Nominal Voltage			12 V
				Nominal Current		5 A	

The HIC B connector allows powering ECU Lane B. Interfaces to indication elements are described in Chapter 77-00-00.

**X1, X2 Connector** [See Chapter 24-00-00 section Interface Description.](#)

**Regulator A** [See Chapter 24-00-00 section 24-00-00 section Interface Description.](#)

**Starter Relay** [See Chapter 80-00-00 section Interface Description](#)

**Wiring harness grounding** The grounding cable must be attached to Fusebox Regulator A. [See Chapter 24-00-00 section Fusebox Regulator A](#)

**Fuel pump** [See Chapter 73-00-00 section Interface Description](#)

# BRP-Rotax INSTALLATION MANUAL

## INTERFACE OVERVIEW — 916 I TYPE C24

916 i TYPE C24

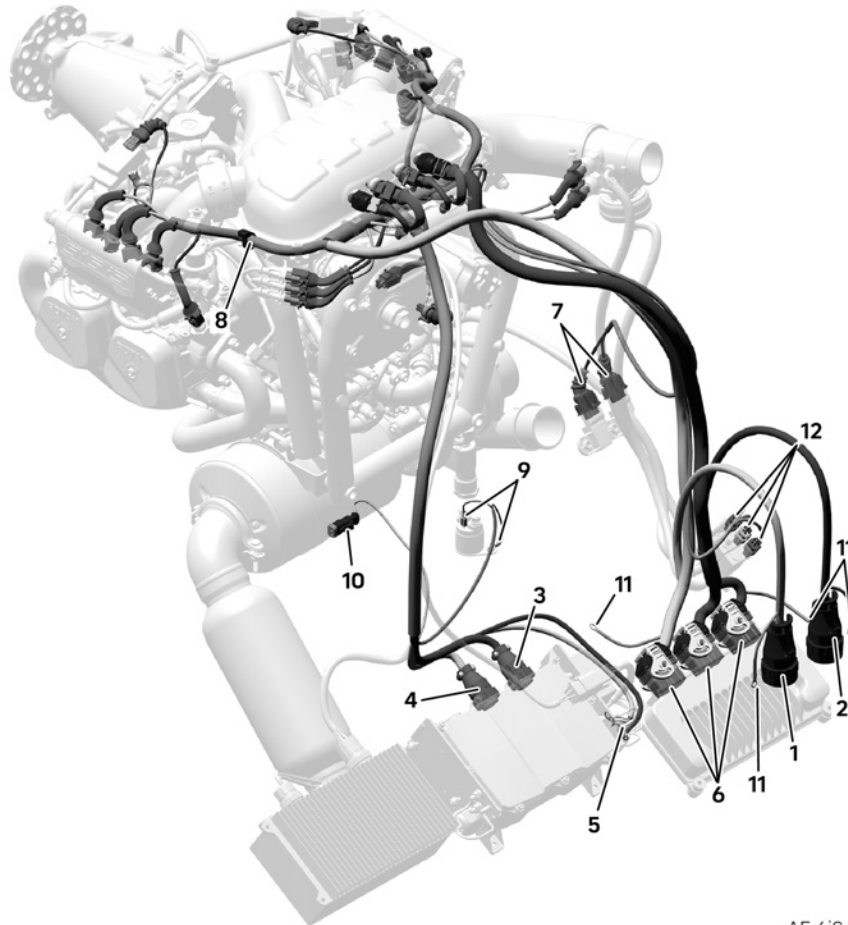

AE\_6iS\_0440

Figure 9.8: Engine Management System (EMS)– Interfaces

- |    |   |    |   |
|----|---|----|---|
| 1  | <i>Harness Interface Connector A (HIC A)<br/>(electrical Interface)</i> | 2  | <i>Harness Interface Connector B (HIC B)<br/>(electrical Interface)</i> |
| 3  | <i>X1 Connector (electrical Interface)</i>                              | 4  | <i>X2 Connector (electrical Interface)</i>                              |
| 5  | <i>Regulator A (electrical Interface)</i>                               | 6  | <i>ECU (electrical, mechanical Interface)</i>                           |
| 7  | <i>AAPTTS (electrical, mechanical<br/>Interface)</i>                    | 8  | <i>Wiring harness</i>   |
| 9  | <i>Starter relay connectors (electrical<br/>Interface)</i>              | 10 | <i>Fuel pump connectors (electrical<br/>Interfaces)</i>                 |
| 11 | <i>Ring terminal Ground cables</i>                                      | 12 | <i>PCV Connector</i>  |

# BRP-Rotax INSTALLATION MANUAL

## ELECTRICAL INTERFACES – 916 i TYPE C24

### Harness interface connector A 916 i TYPE C24

The HIC A connector allows powering ECU Lane A and Fuel Pump A. interfaces to Indication elements are described in Chapter 77-00-00.

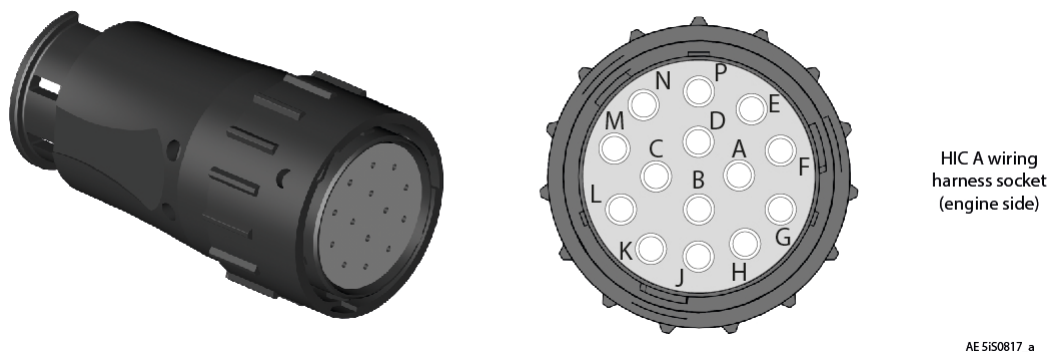
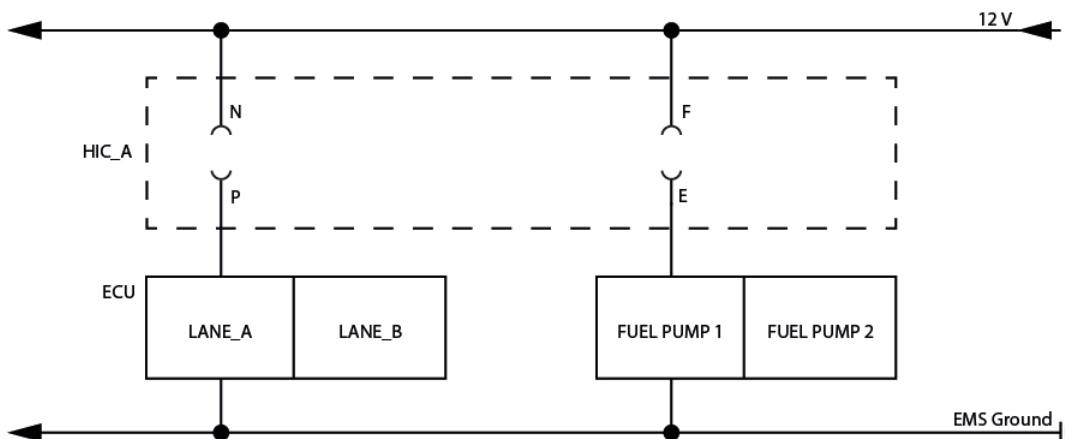

Figure 9.9: HIC A Connector

In case the EMS is powered by an external power source or by one of the internal generators:

- A connection between Terminal N and Terminal P will power ECU Lane A



AE 51S0023\_a

Figure 9.10: HIC A connector –Engine controls

# BRP-Rotax INSTALLATION MANUAL

Terminal (Supply)		Terminal (Ground)		Interface Parameter	Min.	Max.	Nominal
N	LANE_SEL_SW_A_1	P	LANE_SEL_SW_A_2	Nominal Voltage			12 V
				Nominal Current		7.5 A	
F	SIG_FUEL_PUMP_1	E	GND_FUEL_PUMP_1	Nominal Voltage			12 V
				Nominal Current		10 A	

## Harness Interface Connector B

916 i TYPE C24

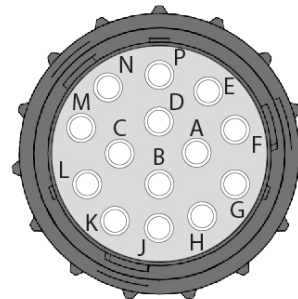

HIC B wiring harness socket (engine side)

AE5IS0818\_a

Figure 9.11: HIC B connector

In case the EMS is powered by an external power source or by one of the internal generators:

- A connection between Terminal N and Terminal P will power ECU Lane B

# BRP-Rotax INSTALLATION MANUAL

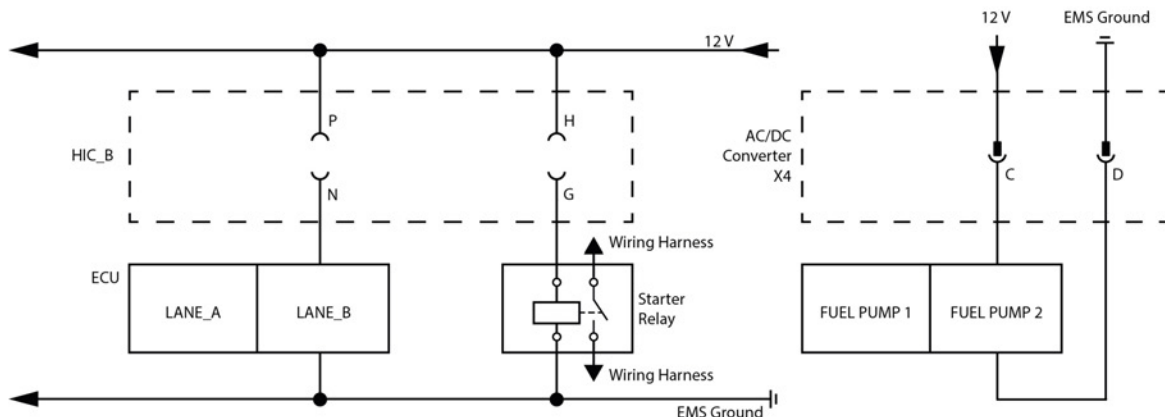

AE 5150022\_a

Figure 9.12: HIC B Connector – Engine controls

Terminal (Supply)		Terminal (Ground)		Interface Parameter	Min.	Max.	Nominal
P	LANE_SEL_SW_B_1	N	LANE_SEL_SW_B_2	Nominal Voltage			12 V
				Nominal Current		7.5 A	
F	SUPP_START_SWITCH	E	CONN_STARTER_REL_SW	Nominal Voltage			12 V
				Nominal Current		5 A	
C	SIG_FUEL_PUMP_2	D	GND_FUEL_PUMP_2	Nominal Voltage			12 V
				Nominal Current		10 A	

The HIC B connector allows powering ECU Lane B. Interfaces to indication elements are described in Chapter 77-00-00.

**X1, X2 Connector** [See Chapter 24-00-00 section Interface Description.](#)

**Regulator A** [See Chapter 24-00-00 section 24-00-00 section Interface Description.](#)

**Wiring harness grounding** The grounding cable must be attached to Fusebox Regulator A. [See Chapter 24-00-00 section Fusebox Regulator A](#)

# BRP-Rotax INSTALLATION MANUAL

## MECHANICAL INTERFACES

Engine Control  
Unit (ECU)

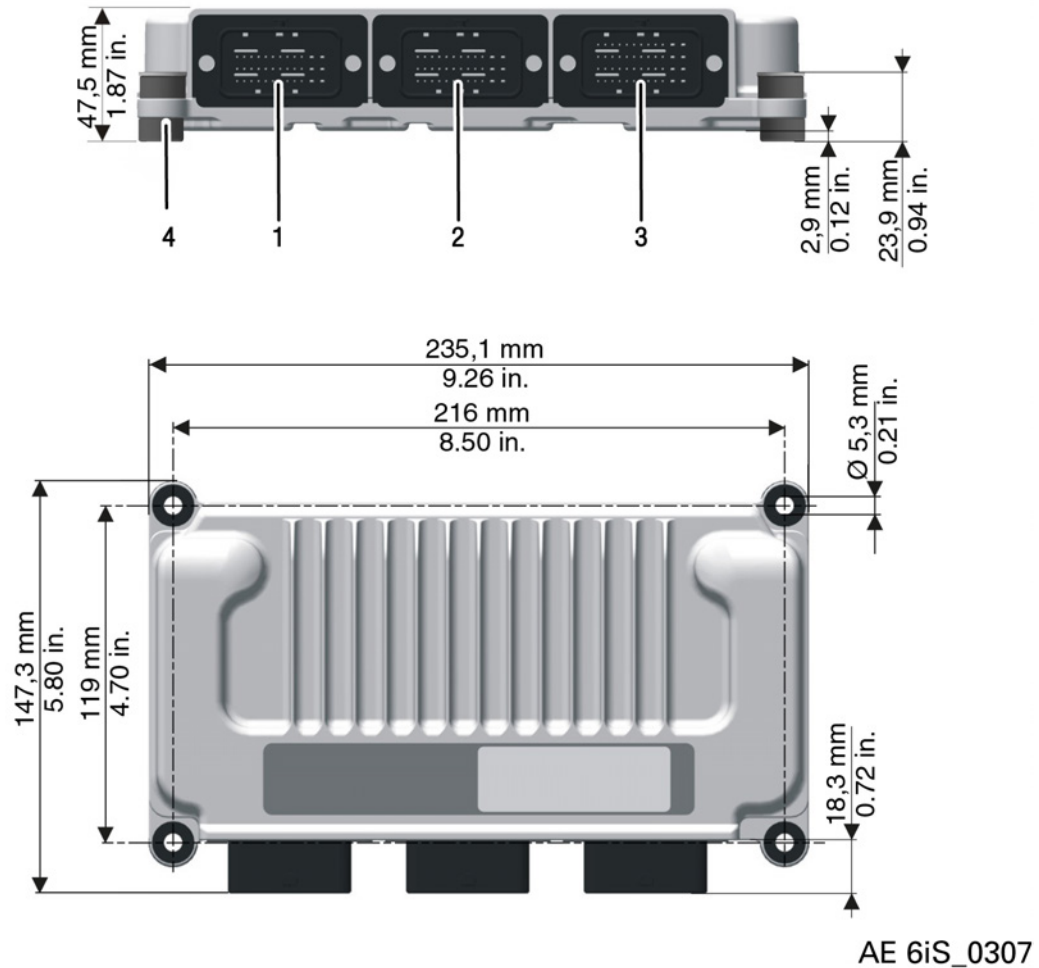

AE 6iS\_0307

Figure 9.13: ECU –mounting points

- |                       |                       |
|-----------------------|-----------------------|
| 1 Connector socket A1 | 2 Connector socket A2 |
| 3 Connector socket B  | 4 Rubber sleeve       |



# BRP-Rotax INSTALLATION MANUAL

## Sensors

### Ambient Air Pressure and Temperature Sensors (AAPT 1, 2)

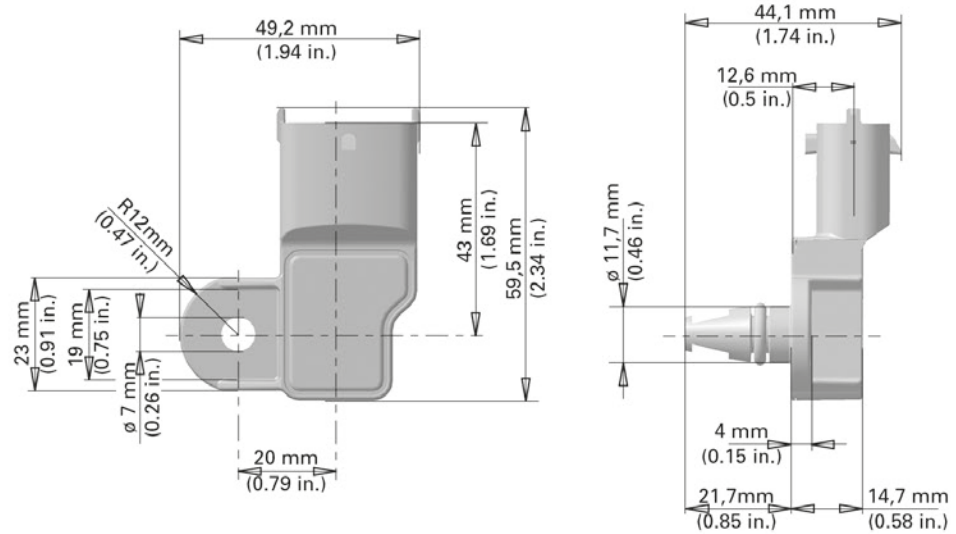

AE 5IS\_0017

Figure 9.14: AAPT 1, 2 – mounting points

Maximum diameter of fastener in the interior of the mounting hole: 6 mm (0.24 in.). Only mount sensor with a washer ( $\varnothing$  10 mm (0.39 in.) or with an adequate fastener head diameter. The maximum permissible pressure at the mounting flange may not exceed 20 N/mm<sup>2</sup> (0.0029 psi).

# BRP-Rotax INSTALLATION MANUAL

## INSTALLATION NOTES

### General

The representation of components in this chapter which are not within scope of the delivery is only symbolic. The design shown in this chapter does not represent a specified execution but should support the understanding of the system.

The final design, the selection and specification of parts according to the respective applicable regulations, the consideration of the system limitations and interface description as well as the comprehension of the operating limits in every operational state is in the responsibility of the aircraft manufacturer.

The aircraft manufacturer has to make sure that the operating limits given in the Operators Manual (OM) can be supervised by the pilot. The execution of the installation must allow the operation of the engine according to the Operators Manual (OM).

### INSTALLATION OVERVIEW

916 i TYPE A

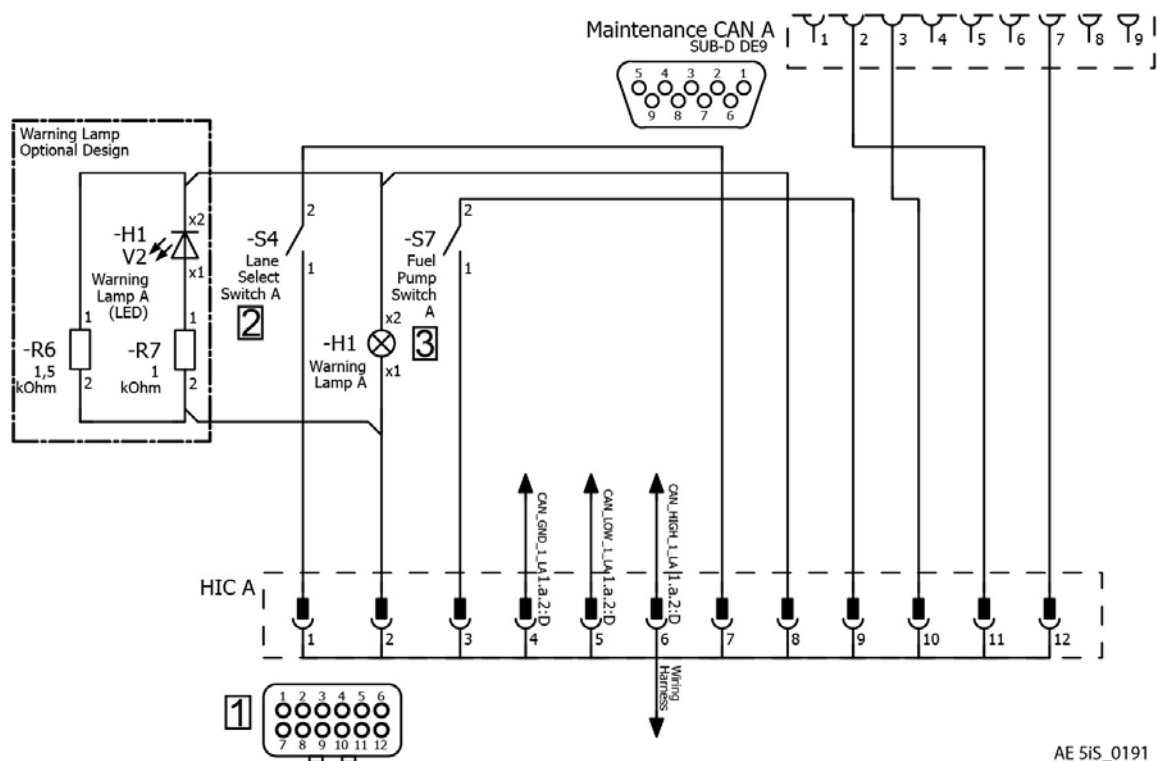

Figure 9.15: Harness Interface Connector A-Schematic

Part	Function
1	Harness Interface Connector A
2	Lane Select Switch A (-S4)
3	Fuel Pump Switch A (-S7)

# BRP-Rotax INSTALLATION MANUAL

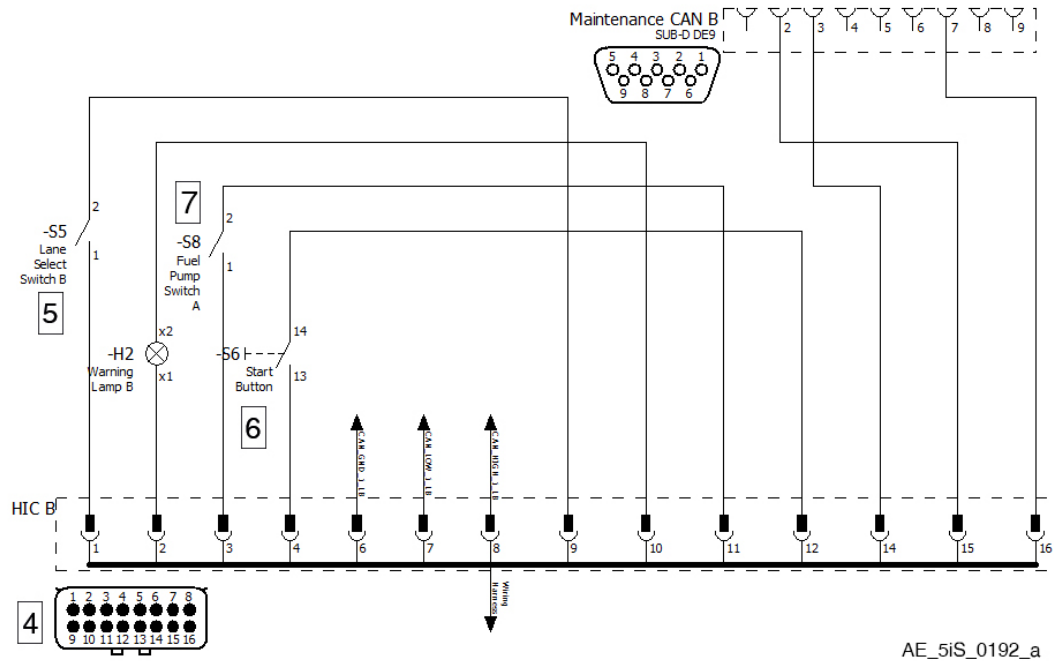

Figure 9.16: Harness Interface Connector B-Schematic

Part	Function
4	Harness Interface Connector B
5	Lane Select Switch B (-S5)
6	Start Switch (-S6)
7	Fuel Pump Switch A (-S8)

# BRP-Rotax INSTALLATION MANUAL

## INSTALLATION OVERVIEW – 916 I TYPE C24

916 i TYPE C24

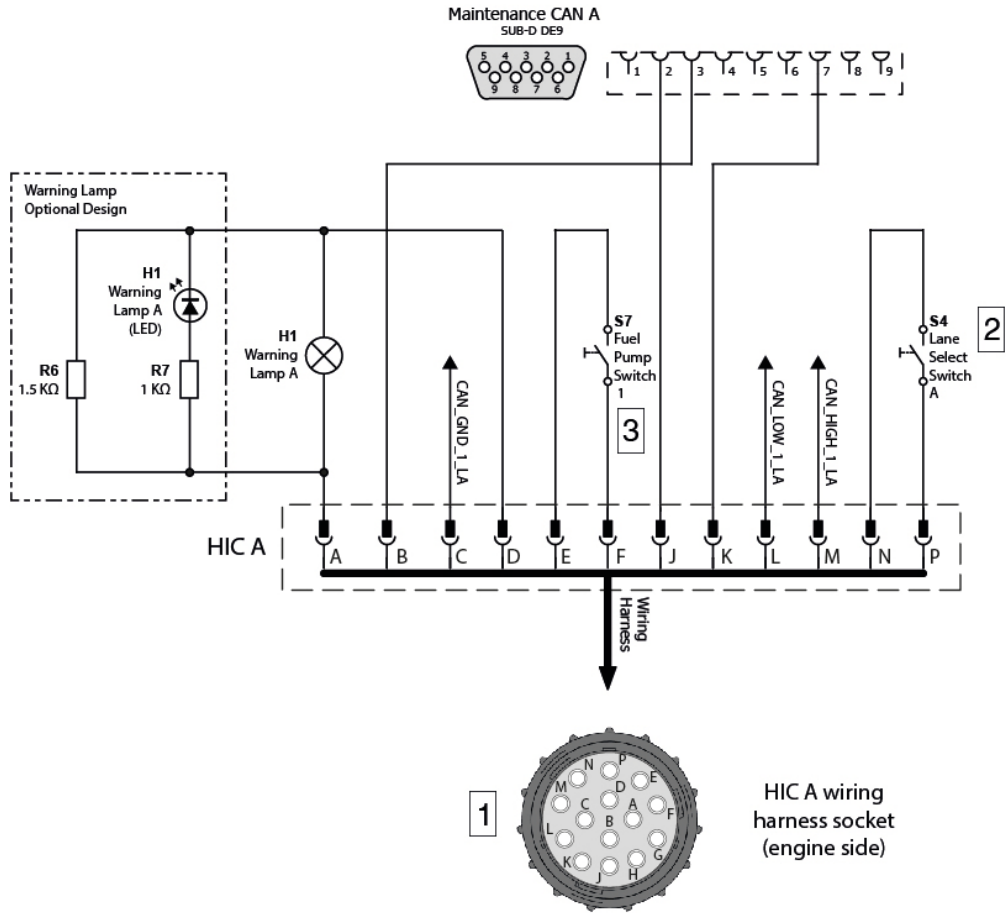

AE 515\_0021\_b

Figure 9.17: Harness Interface Connector A-Schematic

Part	Function
1	Harness Interface Connector A
2	Lane Select Switch A (-S4)
3	Fuel Pump Switch 1 (-S7)

# BRP-Rotax INSTALLATION MANUAL

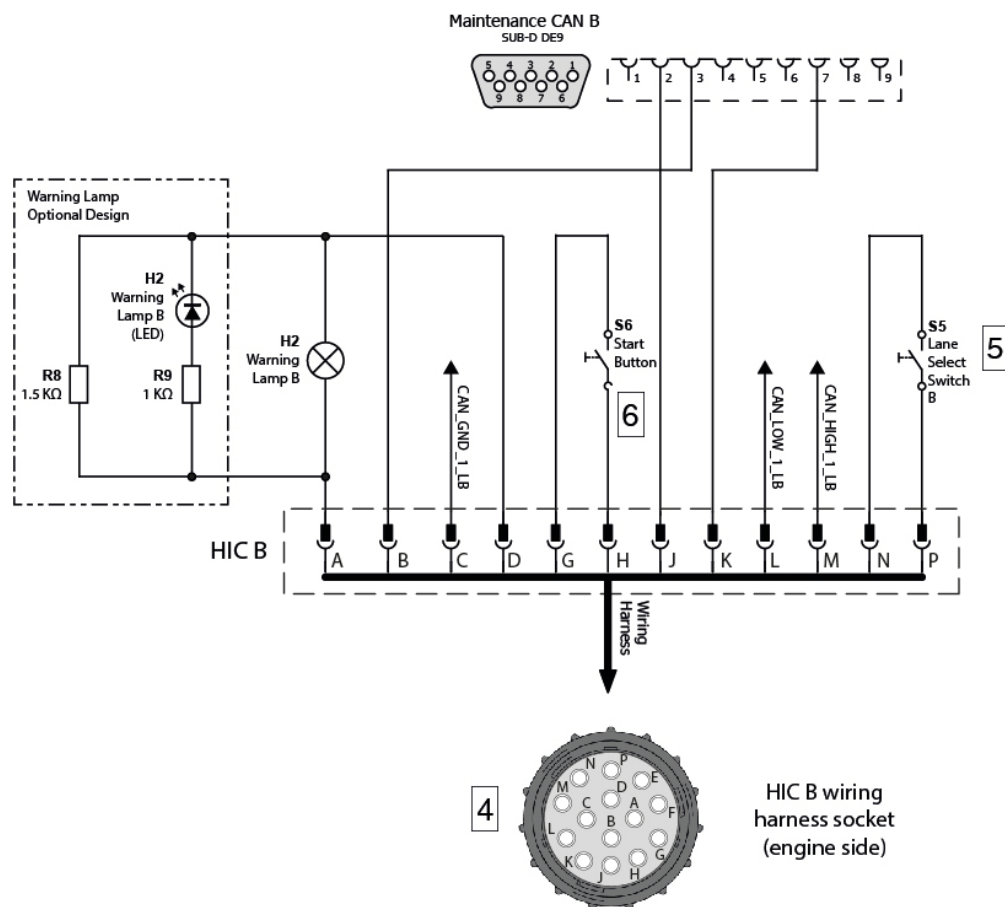

AE 5iS\_0020\_b

Figure 9.18: Harness Interface Connector B-Schematic

Part	Function
4	Harness Interface Connector B
5	Lane Select Switch B (-S5)
6	Start Switch (-S6)

# BRP-Rotax INSTALLATION MANUAL

## LANE SELECT SWITCHES

### Lane Select Switch A (-S4)

Interface Parameter	Value
Switch type	Toggle (normally open)
Nominal voltage	28 V
Nominal current	7.5 A
Number of poles	1-pole

### Lane Select Switch B (-S5)

Interface Parameter	Value
Switch type	Toggle (normally open)
Nominal voltage	28 V
Nominal current	7.5 A
Number of poles	1-pole

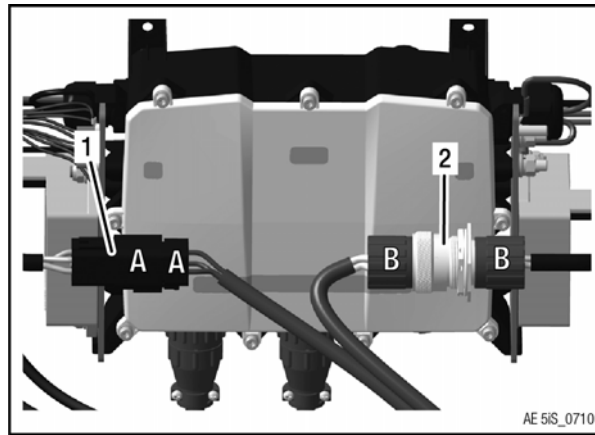

Figure 9.19: Fusebox

1 Connector Regulator A

2 Amphenol connector Regulator B

## START SWITCH

### Start Switch (-S6)

Interface Parameter	Value
Switch type	Button (normally open, non-locking)
Nominal voltage	28 V
Nominal current	5 A
Number of poles	1-pole

**BRP-Rotax**  
INSTALLATION MANUAL

**Chapter: 77-00-00**  
**ENGINE INDICATING**

**TOPICS IN THIS CHAPTER**

<b>System description</b> .....	<b>4</b>
System limitations .....	4
<b>Interface description</b> .....	<b>5</b>
Interface overview .....	5
Electrical interfaces .....	6
Interface overview – 916 I Type C24 .....	9
Electrical interfaces – 916 I Type C24 .....	10
<b>Installation notes</b> .....	<b>13</b>
Installation overview .....	13
Warning lamps .....	15
CAN interfaces .....	15
Installation overview – 916 I Type C24 .....	16
Warning lamps – 916 I Type C24 .....	19
CAN interfaces – 916 I Type C24 .....	19

# BRP-Rotax INSTALLATION MANUAL

916 i TYPE A

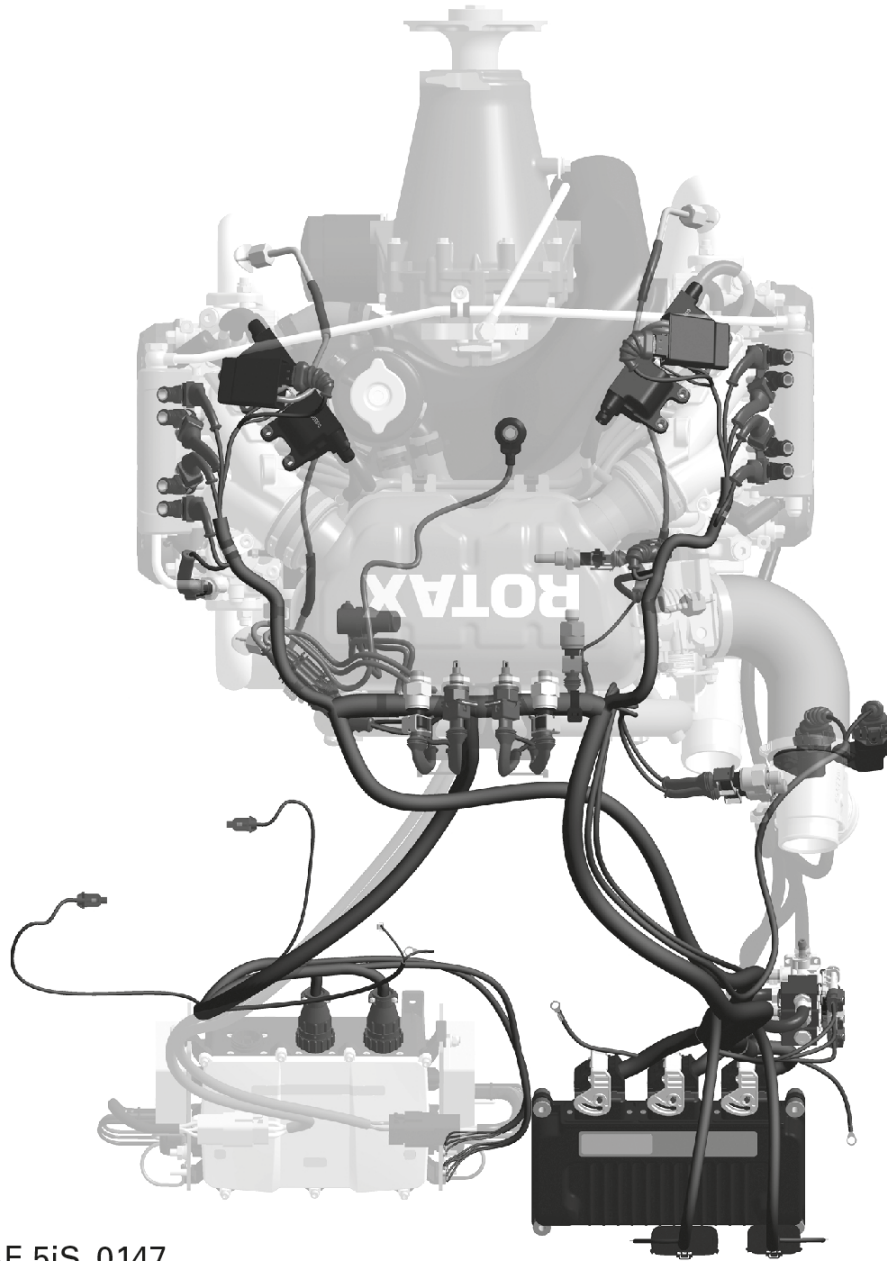

AE 5iS\_0147

Figure 10.1: Engine indication, TYPICAL



# BRP-Rotax INSTALLATION MANUAL

916 i TYPE C 24

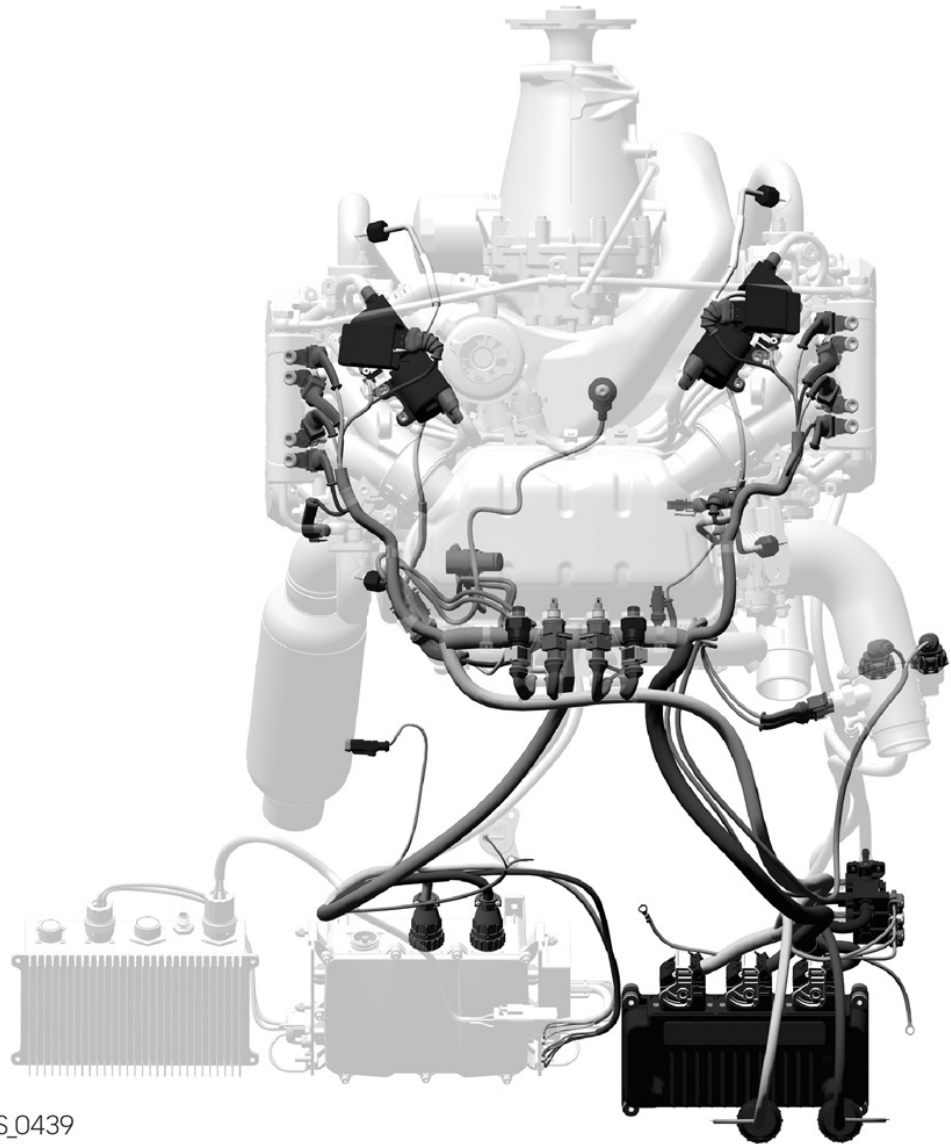

AE\_6iS\_0439

Figure 10.2: Engine indication

# BRP-Rotax INSTALLATION MANUAL

## SYSTEM DESCRIPTION

The complete system is volume of supply and is certified together with the engine. For a detailed system description refer to latest issue of the Operators Manual (OM).

## SYSTEM LIMITATIONS

**Maintenance CAN** The Maintenance CAN must only be used in combination with a B.U.D.S. Aircraft USB-to-CAN converter and *B.U.D.S. Aircraft Software*. It is not possible to use the Maintenance CAN for other displaying or data logging purposes.

**CAN wiring** For the Display- and the Maintenance CAN twisted and shielded cables (3 pins: CAN\_H, CAN\_L, CAN\_GND) must be used for the CAN-connections to ensure a high electromagnetic compatibility in data transmission.

**BRP-Rotax**  
INSTALLATION MANUAL

**INTERFACE DESCRIPTION**

**INTERFACE OVERVIEW**

916 i TYPE A

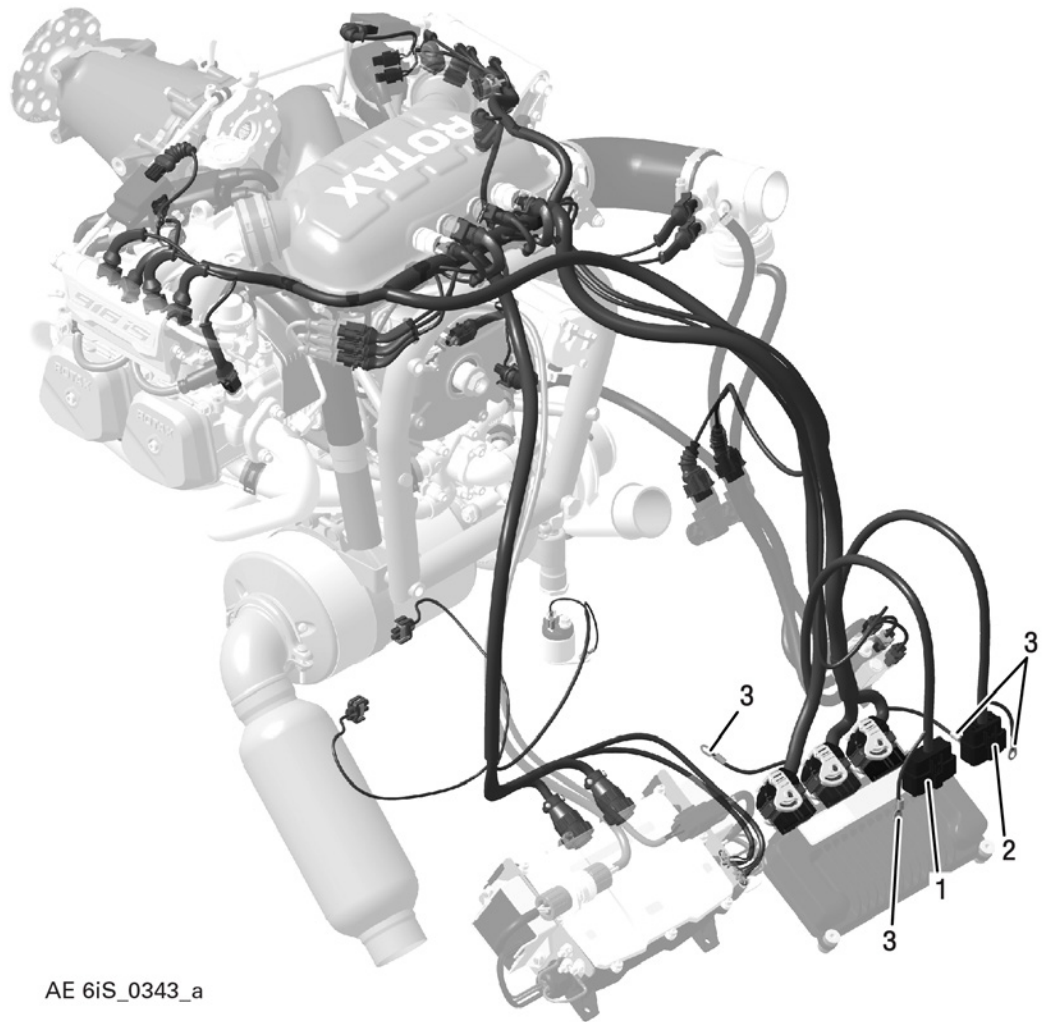

AE 6iS\_0343\_a

Figure 10.3: Engine Management System (EMS) – Interfaces

- 1 *Harness Interface Connector A (HIC A)*
- 2 *Harness Interface Connector B (HIC B)*
- 3 *Electromagnetic shielding of CAN Bus*

# BRP-Rotax INSTALLATION MANUAL

## ELECTRICAL INTERFACES

**Harness Interface Connector A** The HIC Connector A is equipped with a Maintenance CAN interface, a Display CAN interface and terminals which can be used to actuate a warning lamp indicating the current status of the ECU Lane A. Interfaces to control elements are described in Chapter 76-00-00.

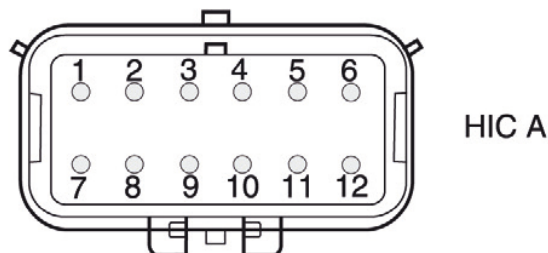

AE 5IS\_0186

Figure 10.4: HIC A Connector

### Warning Lamp

Terminal (Supply)	Terminal (Ground)	Interface Parameter	Min.	Max.	Nominal
2	8	WARN_LAMP_A	Nominal voltage		12 V
			Nominal current		120 mA

### CAN Interfaces

Terminal	Specification
4	Display CAN Lane A
5	
6	
10	Maintenance CAN Lane A
11	
12	

**Connector:** HIC Connector A (included in the engines scope of delivery).

The HIC Connectors must be mounted according to the procedure prescribed in Chapter 76-00-00.

The Display CAN is based on the CAN Aerospace protocol. For detailed interface description contact an authorized ROTAX® Distributor or its independent Service Center.

# BRP-Rotax INSTALLATION MANUAL

**Harness Interface Connector B** The HIC Connector B is equipped with a Maintenance CAN interface, a Display CAN interface and terminals which can be used to actuate a warning lamp indicating the current status of the ECU Lane B. Interfaces to control elements are described in Chapter 76-00-00.

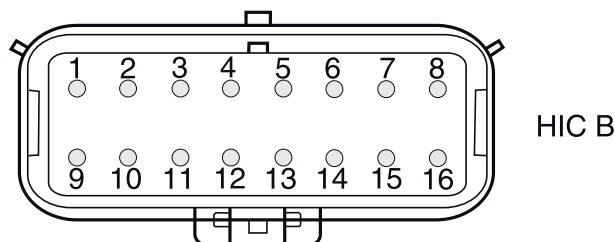

AE 5iS\_0187

Figure 10.5: HIC B connector

### Warning Lamp

Terminal (Supply)	Terminal (Ground)	Interface Parameter	Min.	Max.	Nominal
2	SUPP_WARN_LAMP_B	10	WARN_LAMP_B	Nominal voltage	12 V
				Nominal current	120 mA

### CAN Interfaces

Terminal	Specification
6	Display CAN Lane B
7	
8	
14	Maintenance CAN Lane B
15	
16	

Terminal (Supply)	Terminal (Ground)	Interface Parameter	Min.	Max.	Nominal
2	SUPP_WARN_LAMP_B	10	WARN_LAMP_B	Nominal voltage	12 V
				Nominal current	120 mA

# BRP-Rotax INSTALLATION MANUAL

**Connector:** HIC Connector B (included in the engine's scope of delivery).

The HIC Connectors must be mounted according to the procedure prescribed in Chapter 76-00-00.

The Display CAN is based on the CAN Aerospace protocol. For detailed interface description contact an authorized ROTAX® Distributor or its independent Service Center.

## **Electromagnetic shielding of CAN Bus**

The electromagnetic CAN Bus shielding ring terminals need to be connected with the Airframe Ground.

**Connector:** Ring Terminal M6

# BRP-Rotax INSTALLATION MANUAL

## INTERFACE OVERVIEW – 916 I TYPE C24

916 i TYPE C 24

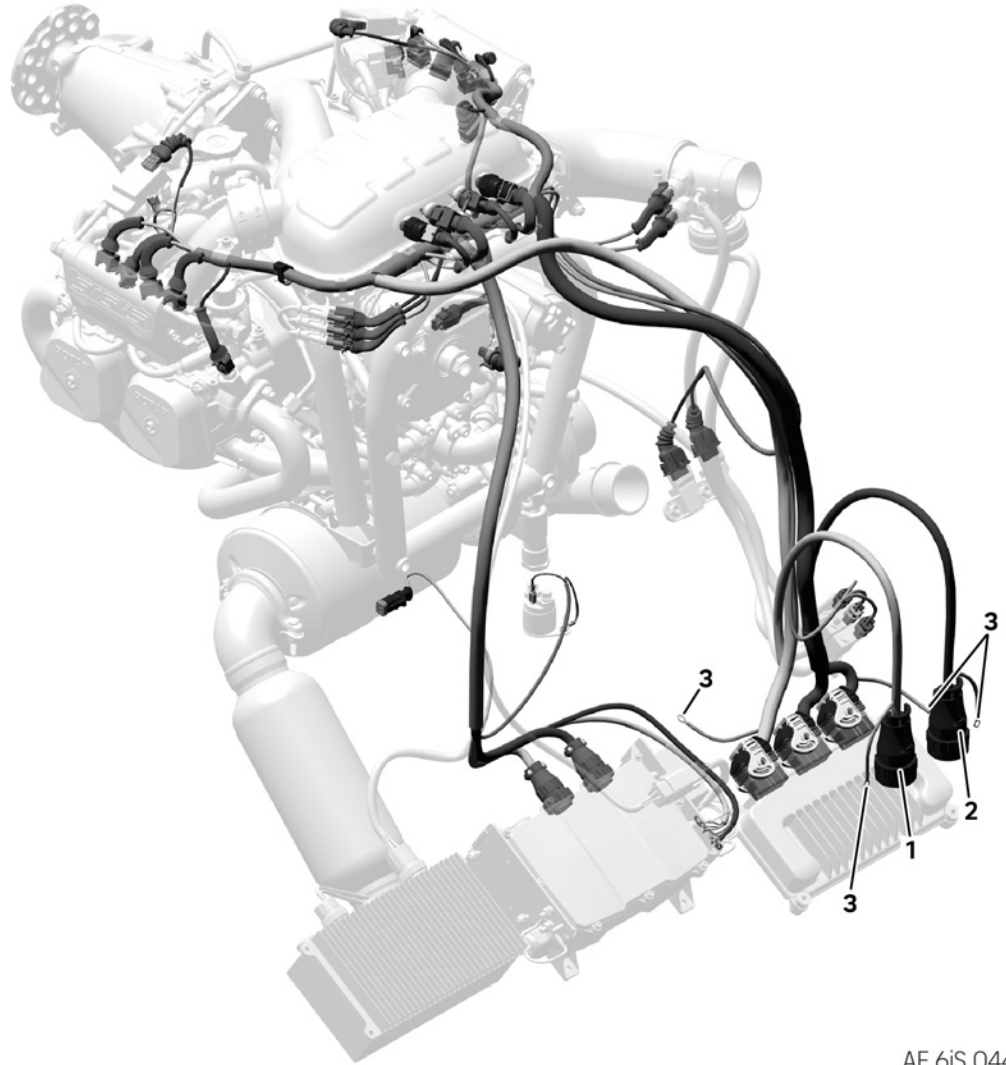

AE\_6iS\_0441

Figure 10.6: Engine Management System (EMS) – Interfaces

- 1 *Harness Interface Connector A (HIC A)*
- 2 *Harness Interface Connector B (HIC B)*
- 3 *Electromagnetic shielding of CAN Bus*

# BRP-Rotax INSTALLATION MANUAL

## ELECTRICAL INTERFACES – 916 i TYPE C24

**Harness Interface Connector A** The HIC Connector A is equipped with a Maintenance CAN interface, a Display CAN interface and terminals which can be used to actuate a warning lamp indicating the current status of the ECU Lane A. Interfaces to control elements are described in Chapter 76-00-00.

916 i TYPE C 24

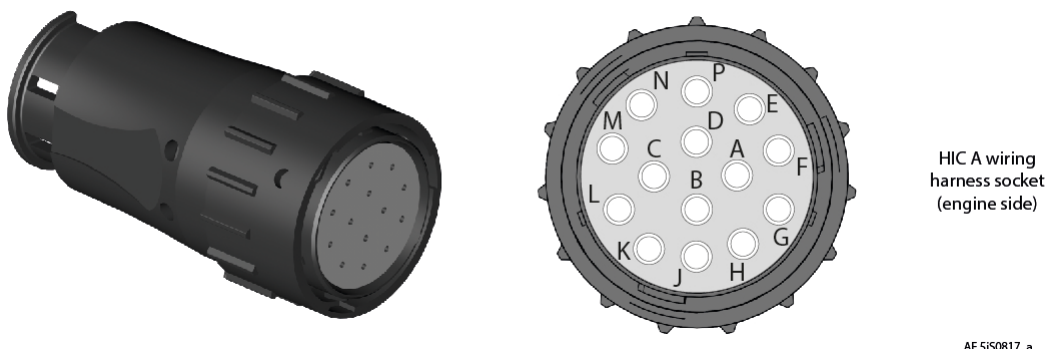

Figure 10.7: HIC A connector

### Warning lamp

Terminal (Supply)	Terminal (Ground)	Interface Parameter	Min.	Max.	Nominal
A	D	WARN_LAMP_A			12 V
		SUPP_WARN_LAMP_A		120 mA	

### CAN Interfaces:

Terminal	Specification
C	Display CAN Lane A
L	
M	
B	Maintenance CAN Lane A
J	
K	

**Connector:** HIC Connector A (included in the engines scope of delivery).  
The HIC Connectors must be mounted according to the procedure prescribed in Chapter 76-00-00.



## BRP-Rotax INSTALLATION MANUAL

The Display CAN is based on the CAN Aerospace protocol. For detailed interface description contact an authorized ROTAX® Distributor or its independent Service Center.

### Harness Interface Connector B

The HIC Connector B is equipped with a Maintenance CAN interface, a Display CAN interface and terminals which can be used to actuate a warning lamp indicating the current status of the ECU Lane B. Interfaces to control elements are described in Chapter 76-00-00.

916 i TYPE C 24

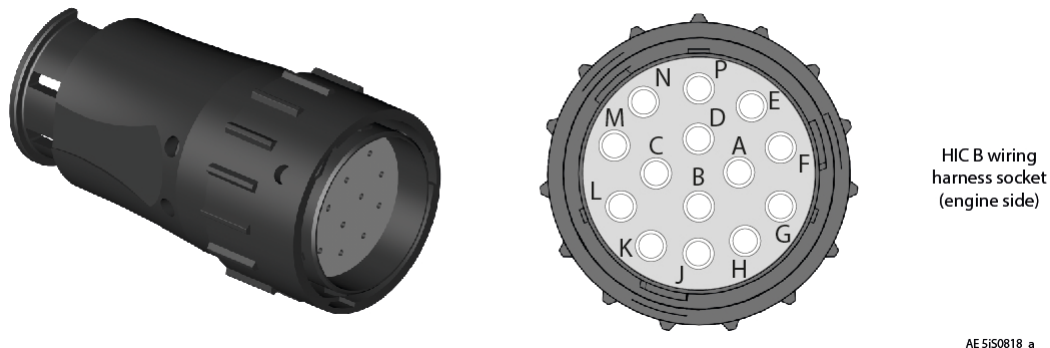

Figure 10.8: HIC B Connector

### Warning lamp

Terminal (Supply)		Terminal (Ground)		Interface Parameter	Min.	Max.	Nominal
A	SUPP_WARN_LAMPE_B	D	WARN_LAMP_B	Nominal voltage			12 V
				Nominal current		120 mA	

### CAN Interfaces

Terminal		Specification
C	CAN_GND_1_B	Display CAN Lane B
L	CAN_LOW_1_B	
M	CAN_HIGH_1_B	
B	CAN_GND_2_B	Maintenance CAN Lane B
J	CAN_LOW_2_B	
K	CAN_HIGH_2_B	

**Connector:** HIC Connector B (included in the engine's scope of delivery).  
The HIC Connectors must be mounted according to the procedure prescribed in Chapter 76-00-00.

# BRP-Rotax INSTALLATION MANUAL

The Display CAN is based on the CAN Aerospace protocol. For detailed interface description contact an authorized ROTAX® Distributor or its independent Service Center.

## **Electromagnetic shielding of CAN Bus**

The electromagnetic CAN Bus shielding ring terminals need to be connected with the Airframe Ground.

**Connector:** Ring Terminal M6

# BRP-Rotax INSTALLATION MANUAL

## INSTALLATION NOTES

### General

The representation of components in this chapter which are not within scope of the delivery is only symbolic. The design shown in this chapter does not represent a specified execution but should support the understanding of the system.

The final design, the selection and specification of parts according to the respective applicable regulations, the consideration of the system limitations and interface description as well as the comprehension of the operating limits in every operational state is in the responsibility of the aircraft manufacturer.

The aircraft manufacturer has to make sure that the operating limits given in the Operators Manual (OM) can be supervised by the pilot. The execution of the installation must allow the operation of the engine according to the Operators Manual (OM).

### INSTALLATION OVERVIEW

**916 i TYPE A**

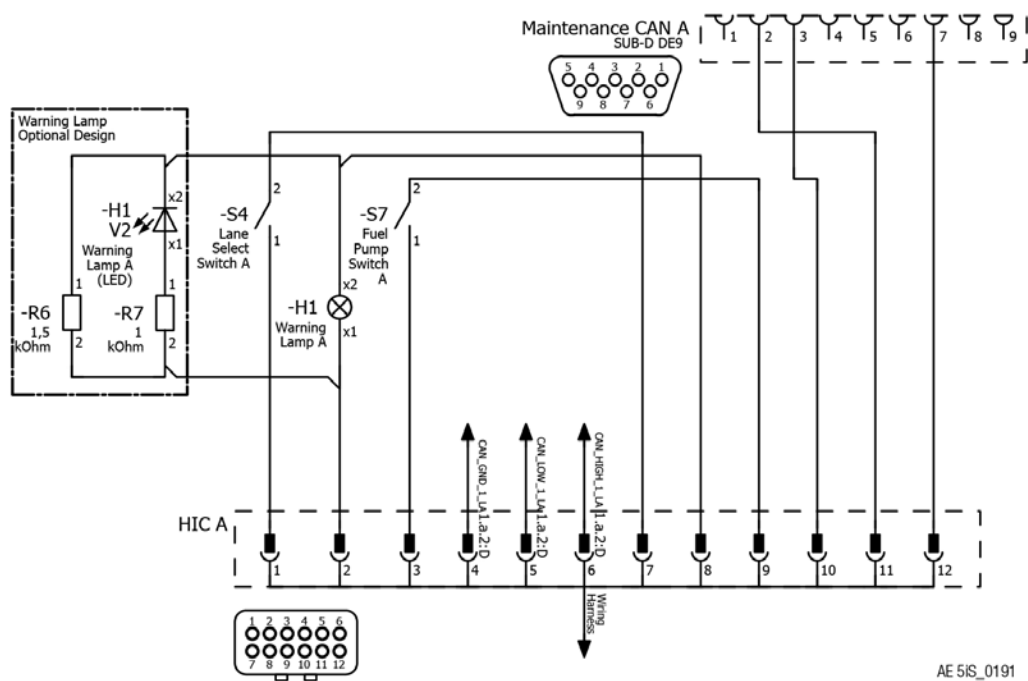

AE 5IS\_0191

Figure 10.9: Harness Interface Connector A-Schematic

Part	Function
1	Harness Interface Connector A
2	Warning Lamp A (-H1)
3	Warning Lamp A (LED) (-H1 V2)
4	Resistor 1.5 kΩ (-F6)
5	Resistor 1 kΩ (-F7)

# BRP-Rotax INSTALLATION MANUAL

6	Display CAN A
7	Maintenance CAN A

**916 i TYPE A**

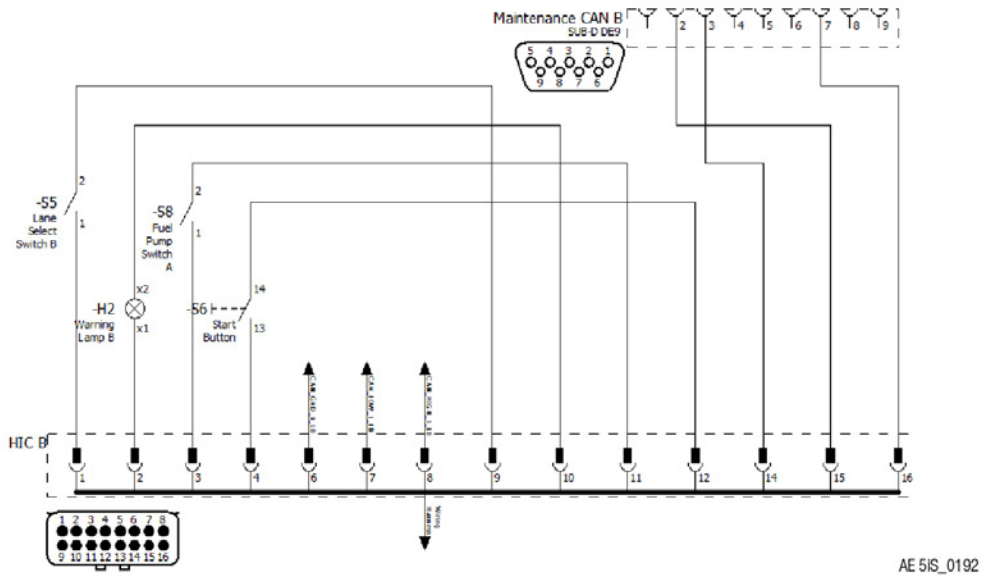

AE 5IS\_0192

Figure 10.10: Harness Interface Connector B – Schematic

Part	Function
8	Harness Interface Connector B
9	Warning Lamp B (-H2)
10	Warning Lamp B (LED) (-H2 V2)
11	Resistor 1.5 kΩ (-F8)
12	Resistor 1 kΩ (-F9)
13	Display CAN B
14	Maintenance CAN B

# BRP-Rotax

## INSTALLATION MANUAL

### WARNING LAMPS

Warning Lamp A, B (-H1, -H2)	Interface Parameter	Value
	Nominal voltage	12
	Nominal current	max. 120 mA

Instead of common lamps also LED lamps (-H1 V2, -H2 V2) can be used. In this case a appropriate pre-resistor must be conducted serial to the LED. An additional resistor parallel to the LED avoids that the ECU detects an open circuit at this warning lamp.

### CAN INTERFACES

**Display CAN** Two independent Display CAN interfaces are provided for displaying or recording engine data. When displaying engine data, it must be ensured that data of both CAN interfaces is used, providing truly redundant data indication or data indication of suitable reliability, consistent with the safety objective of the final application. The proof of consistency with the safety objective of the final application is the responsibility of the installer.

**Maintenance CAN** To be able to connect the Maintenance CAN A and B with the B.U.D.S Aircraft USB-to-CAN converter the Maintenance CAN A and B should be connected with two separate Sub-D DE9 (9-pin) sockets. It is highly recommended to conduct those connectors due to the fact that the B.U.D.S. Aircraft is a central element when it comes to diagnosis and maintenance of this engine.

CAN Type	Description	HIC Pin	Sub-D DE9 Pin
Maintenance CAN A	CAN_LOW_2_A	11 (HIC A)	2
	CAN_GND_2_A	10 (HIC A)	3
	CAN_HIGH_2_A	12 (HIC A)	7
Maintenance CAN B	CAN_LOW_2_B	15 (HIC B)	2
	CAN_GND_2_B	14 (HIC B)	3
	CAN_HIGH_2_B	16 (HIC B)	7

It is recommended not to connect maintenance and diagnostic interfaces Lane A and Lane B together.

# BRP-Rotax INSTALLATION MANUAL

## INSTALLATION OVERVIEW – 916 I TYPE C24

916 i TYPE C 24

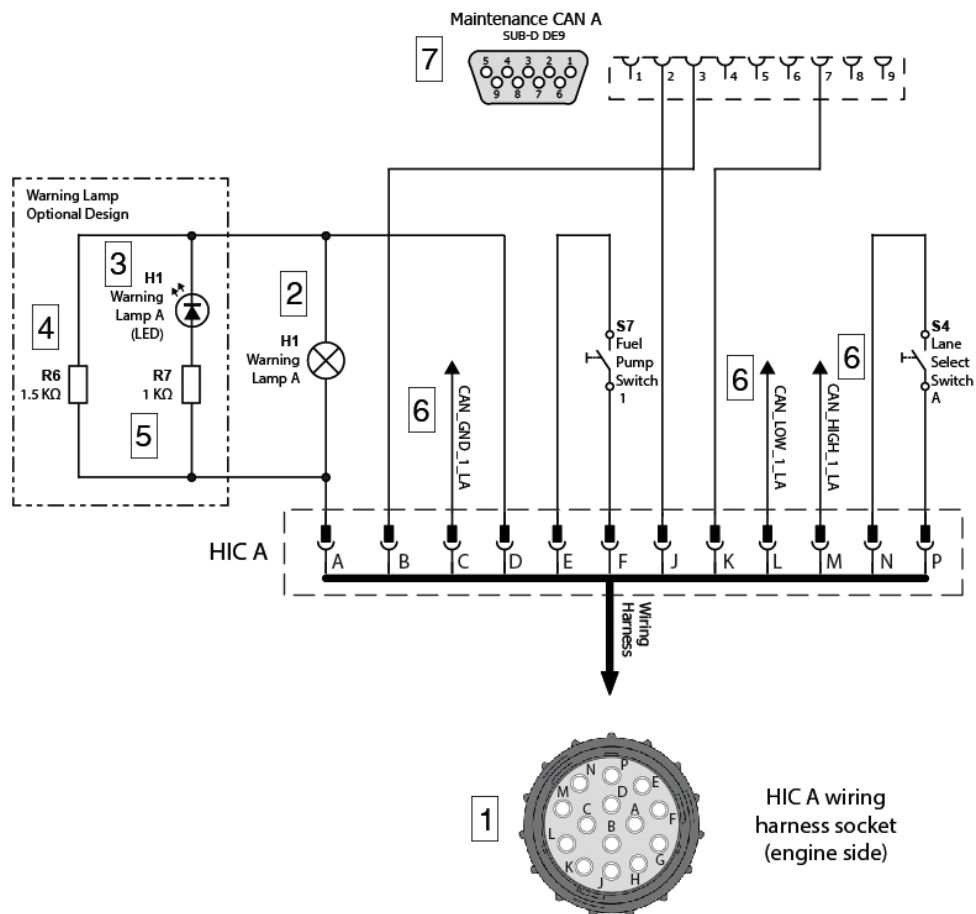

AE 515\_0021\_a

Figure 10.11: Harness Interface Connector A-Schematic

Part	Function
1	Harness Interface Connector A
2	Warning Lamp A (-H1)
3	Warning Lamp A (LED) (-H1 V2)
4	Resistor 1.5 kΩ (-R6)
5	Resistor 1 kΩ (-R7)
6	Display CAN A
7	Maintenance CAN A

# BRP-Rotax INSTALLATION MANUAL

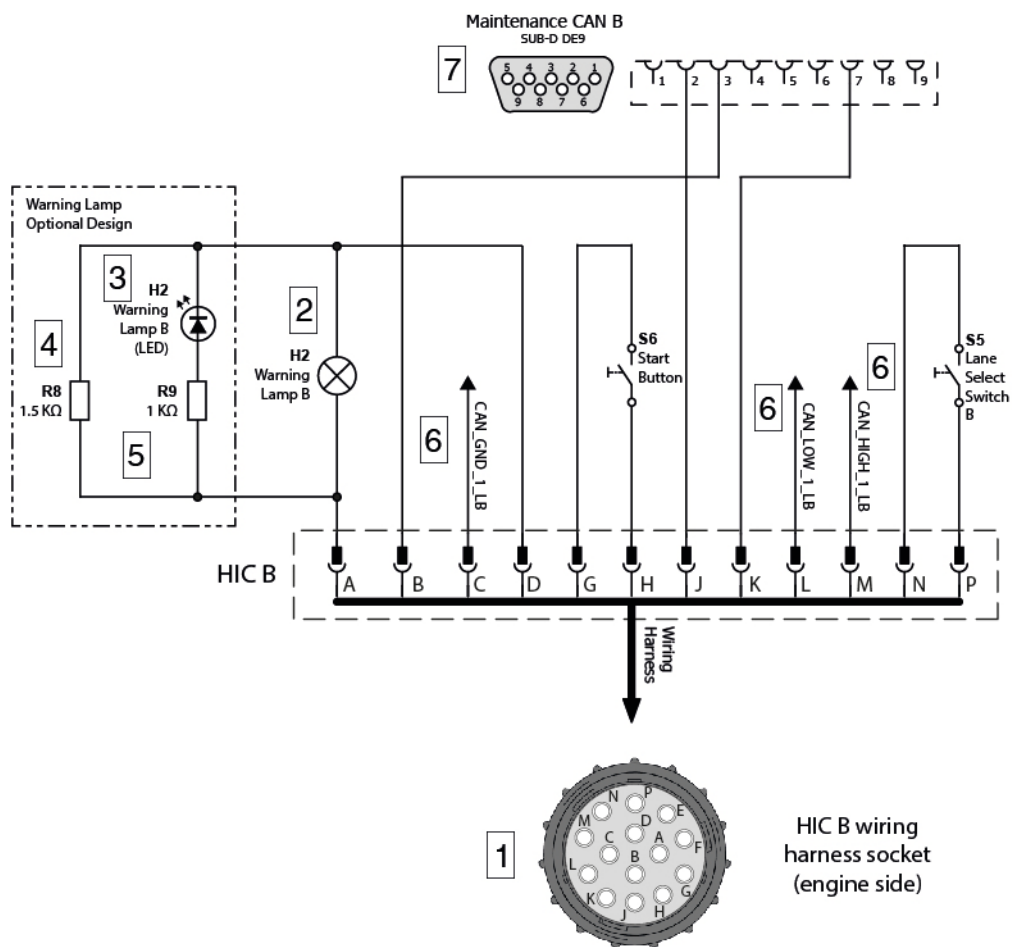

AE 5iS\_0020\_a

Figure 10.12: Harness Interface Connector B-Schematic

Part	Function
1	Harness Interface Connector B
2	Warning Lamp B (-H2)
3	Warning Lamp B (LED) (-H2 V2)
4	Resistor 1.5 kΩ (-R8)
5	Resistor 1 kΩ (-R9)
6	Display CAN B
7	Maintenance CAN B

# BRP-Rotax INSTALLATION MANUAL

Cockpit Airframe  
side

Connector	PIN	Function	Type
X5	X5.1	Aircraft GND for Warning Lamps	Ground
	X5.2	Warning Lamp 14 V output EMS/Fuel pump	Signal
	X5.3	Warning Lamp Command Input (Start Power / Battery Backup)	Signal
	X5.4	Warning Lamp 28 V output Aircraft	Signal

## NOTE

*For improved clarity, see diagrams in Chapter 92-00-00 "Wiring diagrams".*



# BRP-Rotax INSTALLATION MANUAL

## WARNING LAMPS – 916 I TYPE C24

Warning Lamp A,  
B (-H1, -H2)

916 i TYPE C 24

Interface Parameter	Value
Nominal voltage	12 V
Nominal current	max. 120 mA

Instead of common incandescent lamps also LED lamps (-H1 V2, -H2 V2) can be used. In this case a appropriate pre-resistor must be conducted serial to the LED. An additional resistor parallel to the LED prevents the ECU from detecting an open circuit at this warning lamp.

## CAN INTERFACES – 916 I TYPE C24

Display CAN

916 i TYPE C 24

Two independent Display CAN interfaces are provided for displaying or recording engine data. When displaying engine data, it must be ensured that data of both CAN interfaces is used, providing truly redundant data indication or data indication of suitable reliability, consistent with the safety objective of the final application. The proof of consistency with the safety objective of the final application is the responsibility of the installer.

Maintenance  
CAN

To be able to connect the Maintenance CAN A and B with the B.U.D.S Aircraft USB-to-CAN converter the Maintenance CAN A and B should be connected with two separate Sub-D DE9 (9-pin) sockets. It is highly recommended to conduct those connectors due to the fact that the B.U.D.S. Aircraft is a central element when it comes to diagnosis and maintenance of this engine.

CAN Type	Description	HIC Pin	Sub-D DE9 Pin
Maintenance CAN A	CAN_LOW_2_A	J (HIC A)	2
	CAN_GND_2_A	B (HIC A)	3
	CAN_HIGH_2_A	K (HIC A)	7
Maintenance CAN B	CAN_LOW_2_B	J (HIC B)	2
	CAN_GND_2_B	B (HIC B)	3
	CAN_HIGH_2_B	K (HIC B)	7

It is recommended not to connect maintenance and diagnostic interfaces Lane A and Lane B together.

**BRP-Rotax**  
INSTALLATION MANUAL

INTENTIONALLY LEFT  
BLANK

**BRP-Rotax**  
INSTALLATION MANUAL

**Chapter: 78-00-00**  
**EXHAUST SYSTEM**

**TOPICS IN THIS CHAPTER**

**System description** .....3  
    System limitations .....3  
**Interface description** .....4  
    Interface overview .....4  
    Mechanical interfaces .....5

**BRP-Rotax**  
INSTALLATION MANUAL

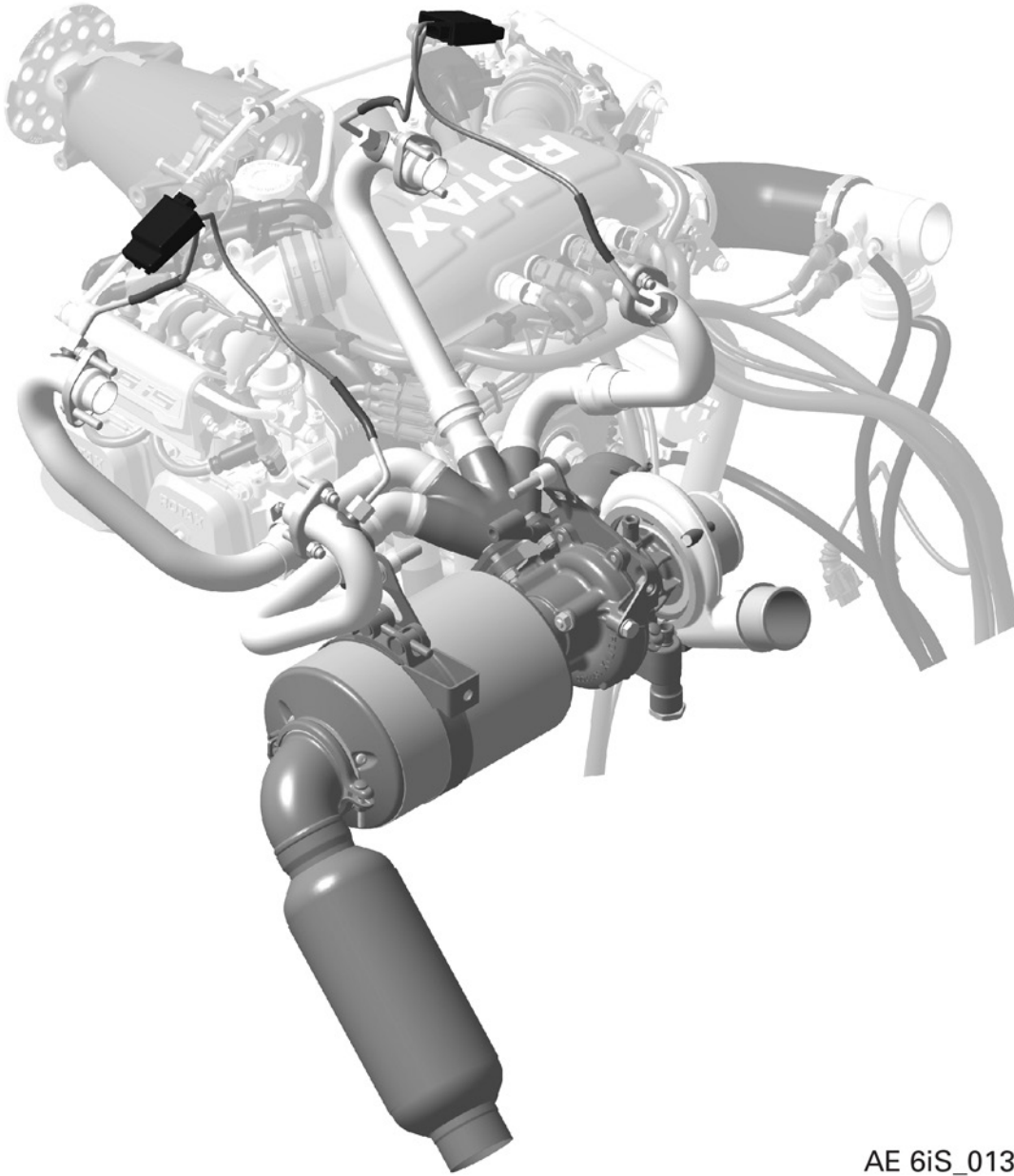

AE 6iS\_0139

Figure 11.1: Exhaust system, TYPICAL

**BRP-Rotax**  
**INSTALLATION MANUAL**

**SYSTEM DESCRIPTION**

The complete system is volume of supply and is certified together with the engine. For a detailed system description refer to latest issue of the Operators Manual (OM).

**SYSTEM LIMITATIONS**

**Operating limits** Refer to latest issue of the Operators Manual (OM).

**Modifications** Modifications of the system by the OEM (e.g. cut the exhaust) may be done, if following requirements are met:

- All exhaust parts added by the OEMs are decoupled (weight and vibration) from the exhaust provided
- Exhaust back pressure must not exceed following limits:

<b>System Limit</b>	<b>Min.</b>	<b>Max.</b>
Exhaust back pressure (ambient pressure: 1000 mbar (14.50 psi))	90 mbar (1.30 psi)	115 mbar (1.66 psi)
Exhaust back pressure (ambient pressure: 900 mbar (13.05 psi))	115 mbar (1.66 psi)	135 mbar (1.95 psi)
Exhaust back pressure (ambient pressure: 800 mbar (11.60 psi))	135 mbar (1.95 psi)	155 mbar (2.24 psi)
Exhaust back pressure (ambient pressure: 700 mbar (10.15 psi))	155 mbar (2.24 psi)	175 mbar (2.53 psi)

**BRP-Rotax**  
INSTALLATION MANUAL

**INTERFACE DESCRIPTION**

**INTERFACE OVERVIEW**

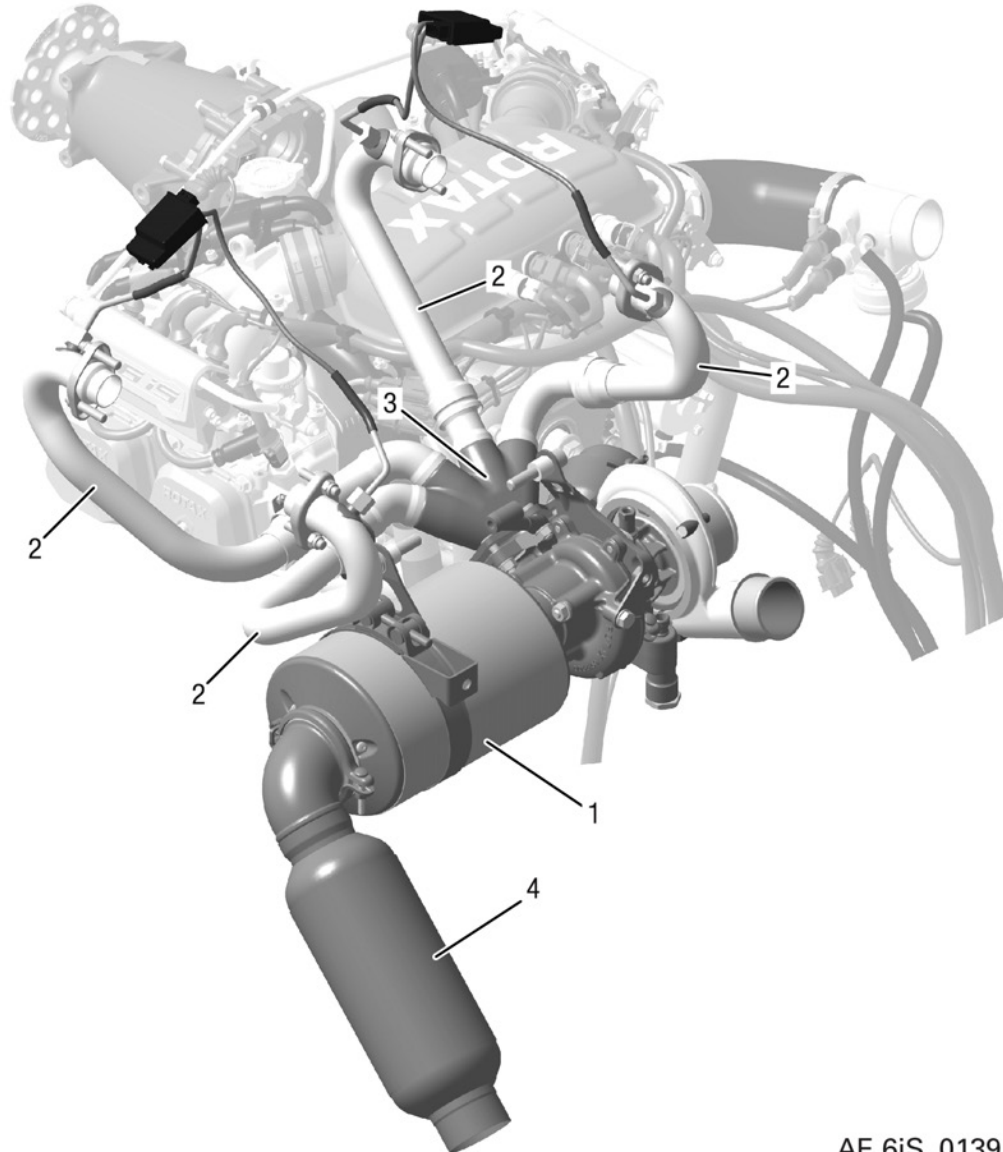

AE 6iS\_0139\_b

Figure 11.2: Exhaust interfaces

- |   |                        |   |                 |
|---|------------------------|---|-----------------|
| 1 | Muffler assy.          | 2 | Exhaust pipe    |
| 3 | Exhaust manifold assy. | 4 | Resonator assy. |

# BRP-Rotax INSTALLATION MANUAL

## MECHANICAL INTERFACES

### Exhaust tail pipe

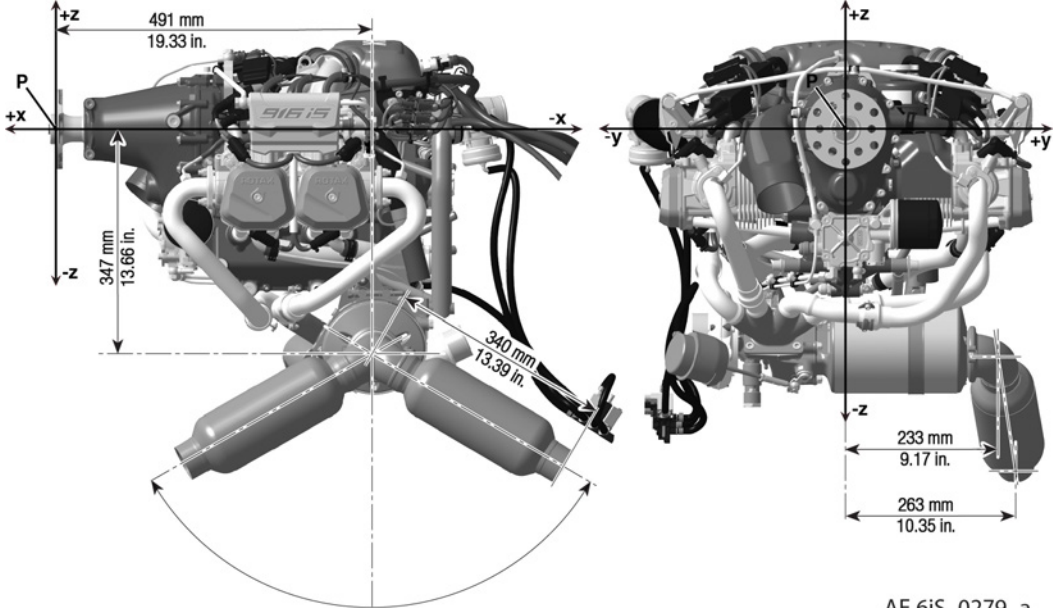

AE 6iS\_0279\_a

Figure 11.3: Exhaust position

Interface Parameter	Value
Exhaust elbow material	X15CrNiSi20-12

**NOTE**

*The resonator can be rotated as desired, but the orientation can only be changed before initial operation. Afterwards M5x12 screws must not be removed.*

**BRP-Rotax**  
INSTALLATION MANUAL

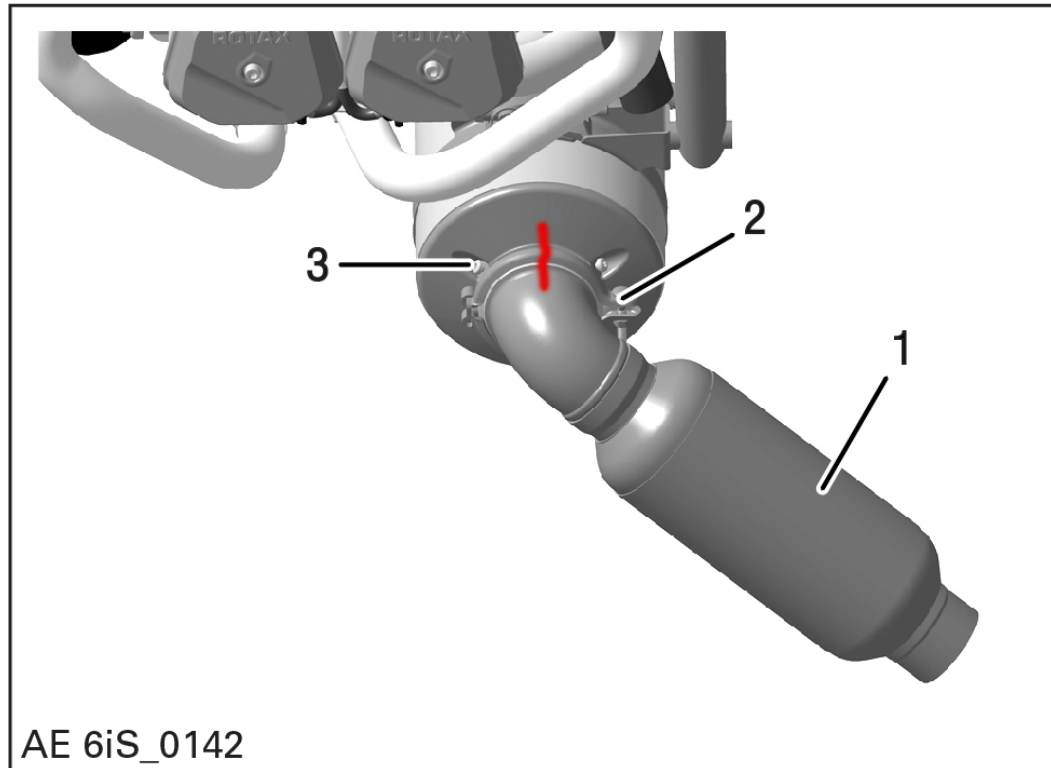

Figure 11.4: Position of the M5x12 screws

1 Muffler

2 V-band clamp assy.

3 M5x12 screws



**BRP-Rotax**  
INSTALLATION MANUAL

**Chapter: 79-00-00**  
**LUBRICATION SYSTEM**

**TOPICS IN THIS CHAPTER**

<b>System description</b> .....	<b>3</b>
System limitations .....	3
Crankcase pressure measurement .....	3
Measuring of the vacuum .....	5
Oil hose requirements .....	7
<b>Interface description</b> .....	<b>8</b>
Interface overview .....	8
Oil tank dimensions .....	8
Oil tank interfaces .....	10
Oil pump .....	11
<b>Installation notes</b> .....	<b>14</b>
Installation overview .....	15
Oil thermostat .....	15
Oil lines .....	16
Oil radiator (optional) .....	16
<b>Filling and purging the oil system</b> .....	<b>18</b>
<b>Validation of installation</b> .....	<b>20</b>
Crankcase pressure measurement .....	20

**BRP-Rotax**  
INSTALLATION MANUAL

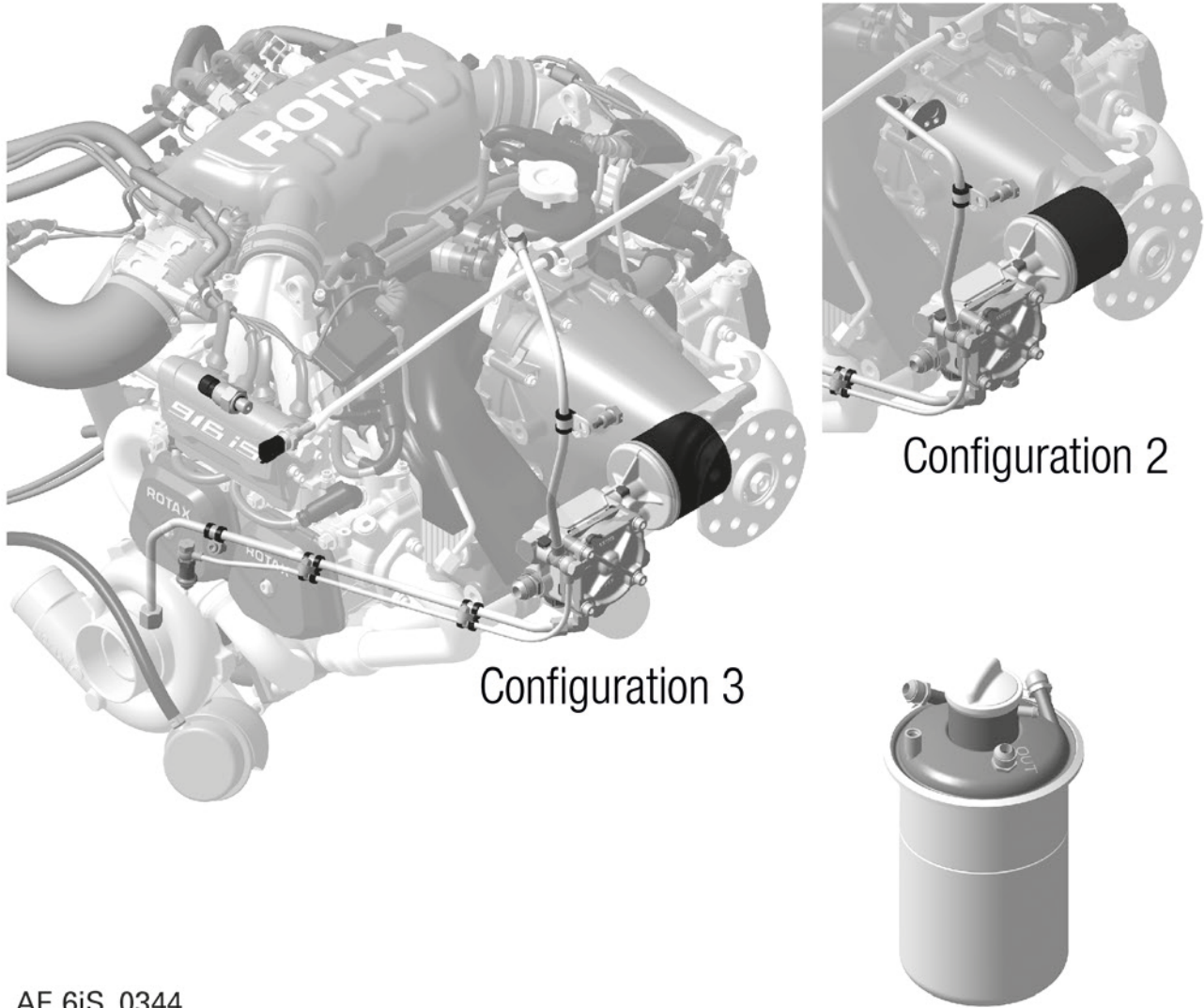

AE 6iS\_0344

Figure 12.1: Lubrication system, TYPICAL

# BRP-Rotax INSTALLATION MANUAL

## SYSTEM DESCRIPTION

For a detailed System description refer to the latest issue of the Operators Manual (OM).

### SYSTEM LIMITATIONS

**Operating limits** Refer to latest issue of the Operators Manual (OM).

#### **⚠ WARNING**

##### **Non-compliance can result in serious injuries or death!**

The lubrication system must be designed such that the permissible operating temperatures and maximum values are not exceeded.

### CRANKCASE PRESSURE MEASUREMENT

Measurement of the mean crankcase pressure at full throttle, this ensures correct oil return from crankcase (blow-by gas).

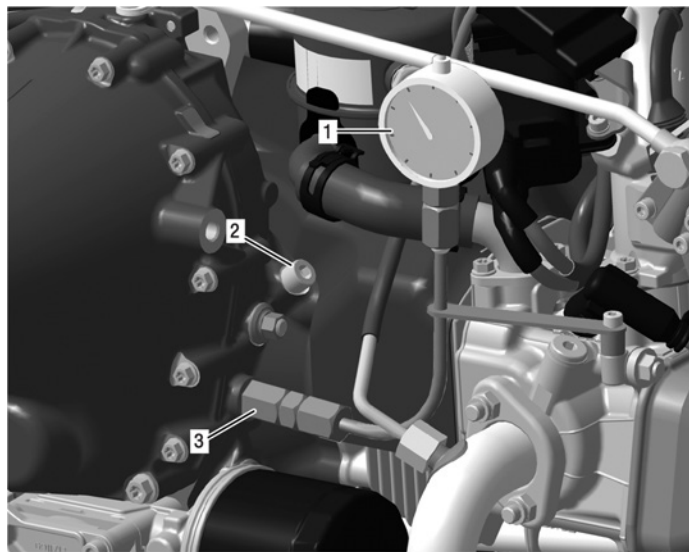

Figure 12.2: Measurement of crankcase pressure

1 *Pressure indicator*

2 *Allen screw M8x20 (position for crankshaft locking screw)*

3 *Magnetic plug (position for adapter)*

#### **NOTICE**

##### **Leakage may occur!**

Always use a new sealing ring with Allen screw M8 (position for crankshaft locking screw).

# BRP-Rotax INSTALLATION MANUAL

## NOTICE

**Do not remove the magnetic plug for prolonged periods and do not use the measurement equipment during flight operations.**

A pressure sensor (pressure gauge with liquid damping) can be fitted instead of the magnetic plug or the crankshaft locking screw. The magnetic plug or the crankshaft locking screw is removed and the pressure sensor is fitted.

### Magnetic plug

The thread for the magnetic plug must be M12x1.5 (metric).

### Pressure values

The pressure in the crankcase at (full throttle) must not exceed the prevailing ambient pressure by more than 0.3 bar (4.35 psi) at 50 °C (122 °F) oil temperature.

## ⚠ WARNING

### **Non-compliance can result in serious injuries or death!**

If the readings exceed the pressure limits, then the flow resistance in the oil return line from oil sump to oil tank is too high in the current engine installation (contamination, restrictions of cross-section, etc.). This condition is unsafe and must be rectified immediately.

# BRP-Rotax INSTALLATION MANUAL

## MEASURING OF THE VACUUM

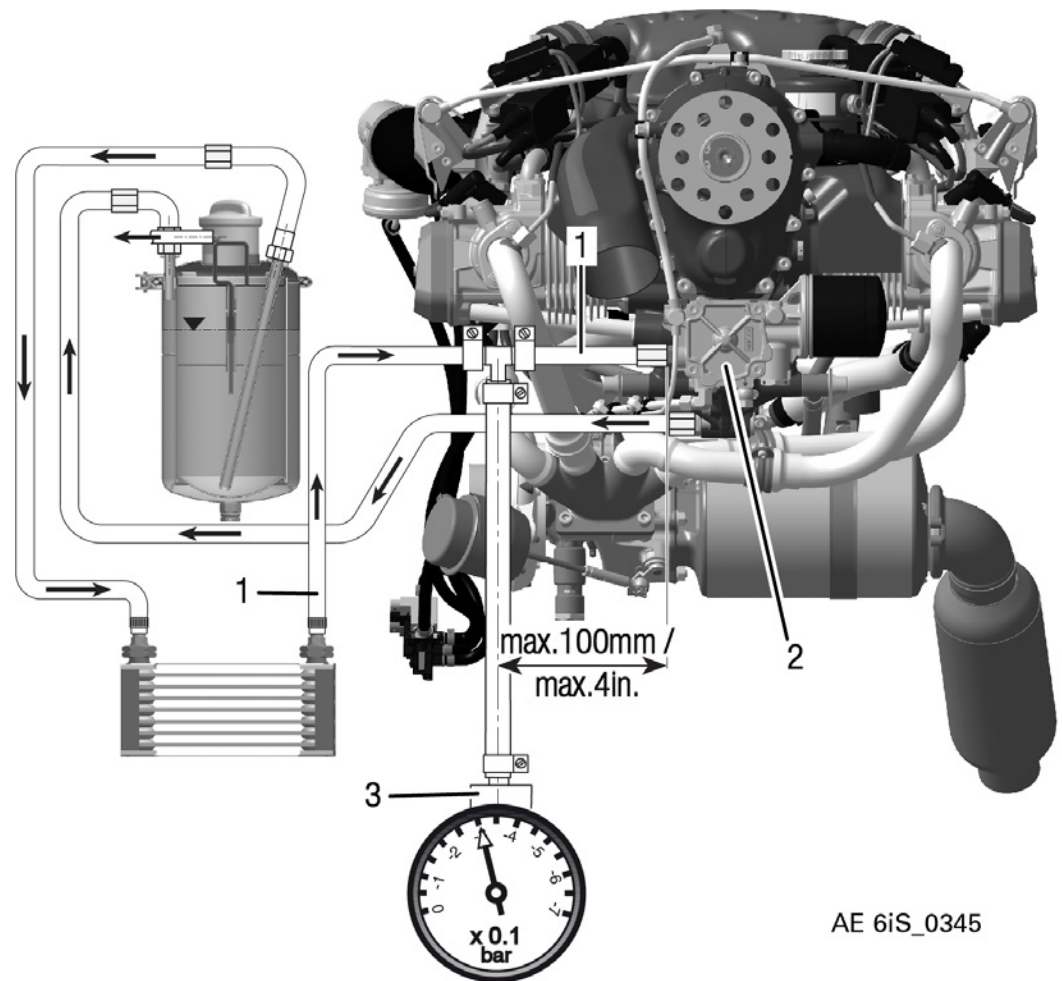

Figure 12.3: Measuring of the vacuum

- 1 Suction oil hose
- 2 Oil pump housing
- 3 Pressure gauge with liquid damping for vacuum

Measure the vacuum in the suction oil hose- from the oil tank via the oil cooler to the engine oil pump - at a distance of max. 100 mm (4 in.) from the oil pump suction connector.

If crankcase pressure and measuring pressure of the vacuum readings and all operational data (flight attitude, temperatures, etc.) are within the specified limits, then it can be assumed that the oil circuit is working correctly.

### Pressure loss

Pressure loss in suction line ( $p_{\text{ambient}} - p_{\text{oil pump inlet}}$ ) must not exceed 350 mbar (5 psi) between 70 °C – 90 °C (158 °F – 194 °F) oil temperature.

# BRP-Rotax INSTALLATION MANUAL

## ⚠ WARNING

### Non-compliance can result in serious injuries or death!

The vacuum must be verified over the complete engine operation range. If the oil is cold, the flow resistance increases, which means that not enough oil will flow on the suction side.

## Oil tank installation positions

### Oil tank

System Limit	Min.	Max.
Angular deviation	- 10°	+ 10°
Tank position in relation to engine	+40 mm (+1.57 in.)	-360 mm (-14.17 in.)

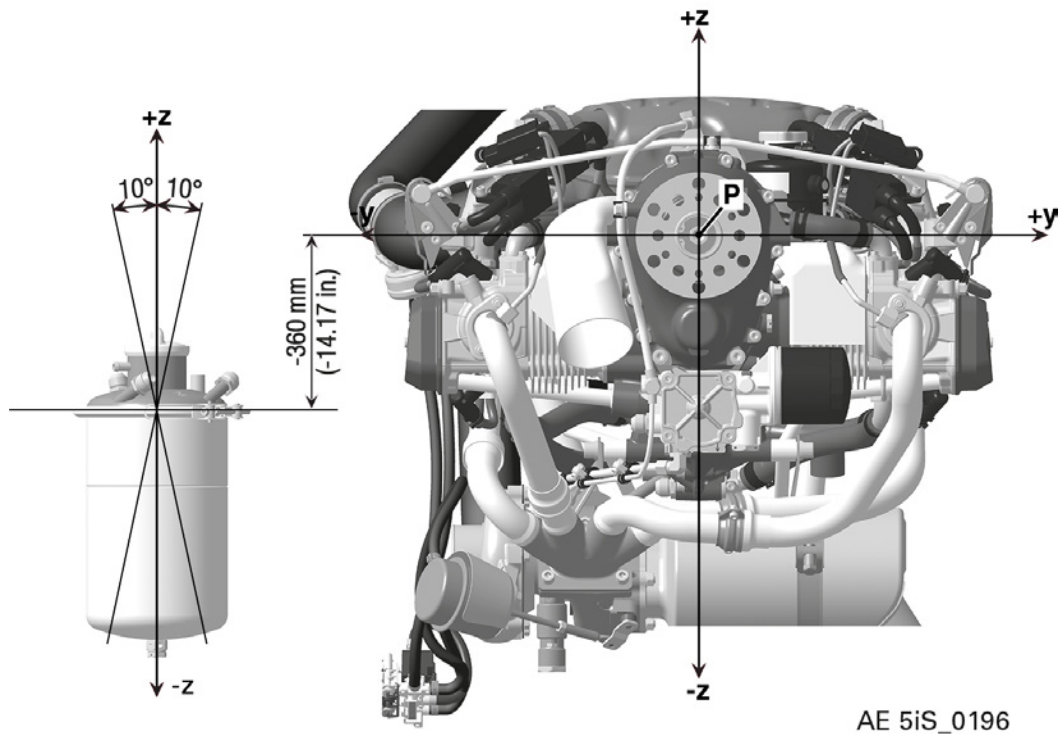

AE 5iS\_0196

Figure 12.4: Oil tank installation position, TYPICAL

The oil tank must be installed on a low-vibration position and not on the engine directly. The oil tank cover and the oil drain screw must be easily accessible.

### NOTE

*The oil tank has to be positioned on its z-axis such that the normal oil level is always between 0 and -360 mm (-14.17 in.) on the z-axis.*

# BRP-Rotax INSTALLATION MANUAL

## WARNING

### **Non-compliance can result in serious injuries or death!**

At higher positioning of the oil tank, oil might leak through clearances at bearings back into crankcase. Oil tank will be empty and all oil will be in the crankcase. If fitted too low it might happen that the oil filter will be drained. In that case oil pressure will be too low for the first seconds after starting the engine.

## OIL HOSE REQUIREMENTS

### **Main oil pump (Oil circuit, engine)**

At negative pressure of -500 mbar (-7.25 psi) and a oil temperature of 150 °C (302 °F) the oil lines must not collapse.

A minimum inner diameter of at least 10 mm (0.39 in.) should be used.

### **NOTE**

*Obey the pressure requirements on interfaces as specified, see crankcase pressure and vacuum measurement.*

**BRP-Rotax**  
INSTALLATION MANUAL

**INTERFACE DESCRIPTION**

**INTERFACE OVERVIEW**

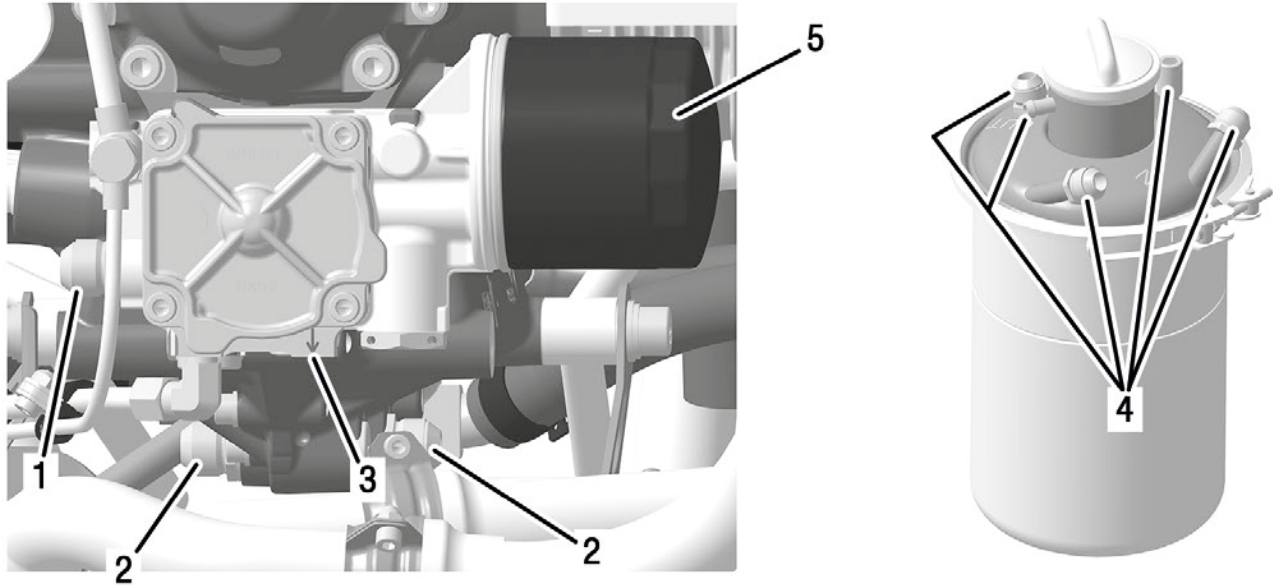

AE 5iS\_0197

Figure 12.5: Lubrication system interfaces

- |   |  |   |  |
|---|--|---|--|
| 1 | Oil pump inlet (hydraulic interface)                   | 2 | Oil return outlet (hydraulic interface)        |
| 3 | Oil return outlet (turbocharger) (hydraulic interface) | 4 | Oil tank in- and outlets (hydraulic interface) |
| 5 | Oil filter (hydraulic interface)                       |   |  |

**OIL TANK DIMENSIONS**

**Oil tank**            The oil tank must be mounted by using appropriate clamps.



# BRP-Rotax INSTALLATION MANUAL

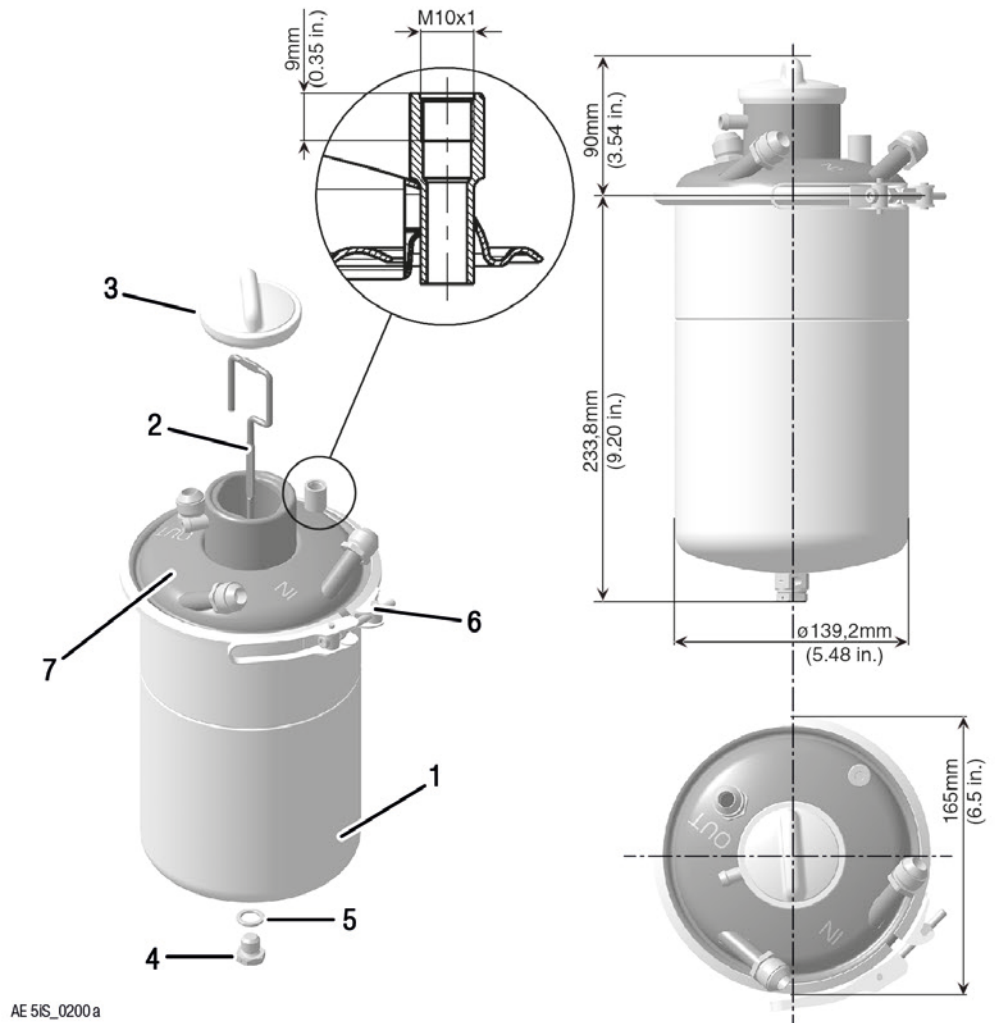

AE 5iS\_0200 a

Figure 12.6: Oil tank dimensions

- |   |                                      |   |                   |
|---|--------------------------------------|---|-------------------|
| 1 | Oil tank                             | 2 | Oil dipstick      |
| 3 | Oil tank cover                       | 4 | Plug screw M12x12 |
| 5 | Gasket ring C12x18                   | 6 | Profile clamp 163 |
| 7 | Oil tank cover assy. (metric or UNF) |   |                   |

# BRP-Rotax INSTALLATION MANUAL

## OIL TANK INTERFACES

Oil tank inlet and outlet

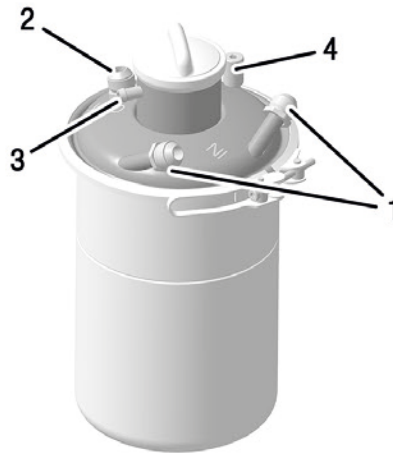

AE 5IS0199

Figure 12.7: Oil tank interfaces

- |                  |                                  |
|------------------|----------------------------------|
| 1 Oil tank inlet | 2 Oil tank outlet                |
| 3 Vent socket    | 4 Oil tank inlet (turbo charger) |

### NOTE

The oil tank cover is also marked: *IN* — oil tank inlet, *OUT* — oil tank outlet.

NOTICE
Both oil tank inlets must be connected with the oil return outlets.

2x Oil tank inlet

Interface Parameter	Value
Screw socket	M18x1.5 or 3/4–16 UNF
Tightening torque	25 Nm (18 ft. lb)

Oil tank outlet

Interface Parameter	Value
Screw socket	M22x1.5 or 7/8–14 UNF
Tightening torque	25 Nm (18 ft. lb)

# BRP-Rotax INSTALLATION MANUAL

Vent socket

Interface Parameter	Value
Outside diameter	8 mm (0.31 in.)
Slip-on length	15 mm (0.59 in.)

## **⚠ WARNING**

**In any case the vent fitting must ensure a release of pressure from the oil tank at any time. Otherwise oil could emerge into the turbo housing which conveys through the exhaust. Formation of smoke is possible.**

Oil tank inlet (turbo charger)

Interface Parameter	Value
Screw socket	M10x1
Tightening torque	15 Nm (133 in. lb)

## OIL PUMP

Oil pump inlet

The oil pump inlet must be connected directly with the oil tank outlet.

Interface Parameter	Value
Screw socket	M22 x1.5 or 7/8–14 UNF
Tightening torque	25 Nm (18 ft. lb)

Oil return outlet

The oil return outlet must be connected directly with the oil tank inlet.

# BRP-Rotax INSTALLATION MANUAL

## NOTICE

Both oil return outlets need to be used. Only the oil return lines on magneto side must be used. The hoses must have approx. the same length.

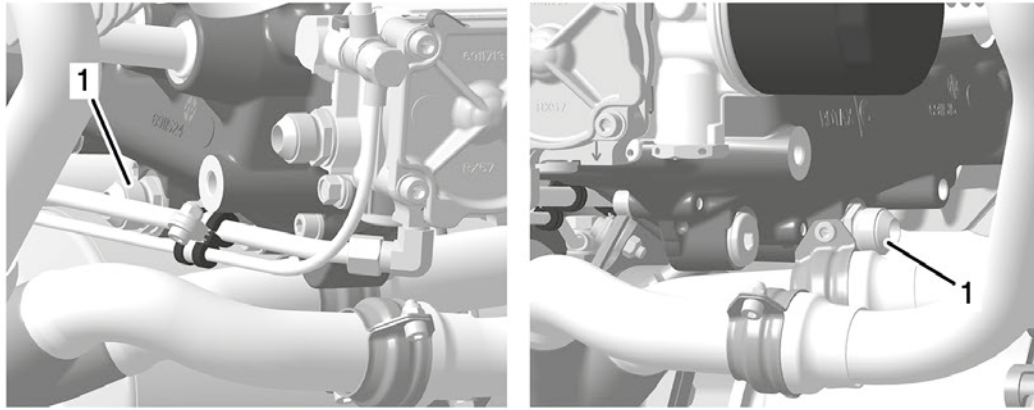

AE 5IS\_0198

Figure 12.8: Oil return outlets

1 Oil return outlet

## BRP-Rotax INSTALLATION MANUAL

Interface Parameter	Value
Screw socket	M18 x 1.5 or 3/4–16 UNF
Tightening torque	25 Nm (18 ft.lb)

### Oil return outlet (turbo charger)

The oil return outlet (turbo charger) must be connected directly with the oil tank inlet (turbo charger).

Interface Parameter	Value
Screw socket	M10 x 1
Tightening torque	15 Nm (133 in. lb)

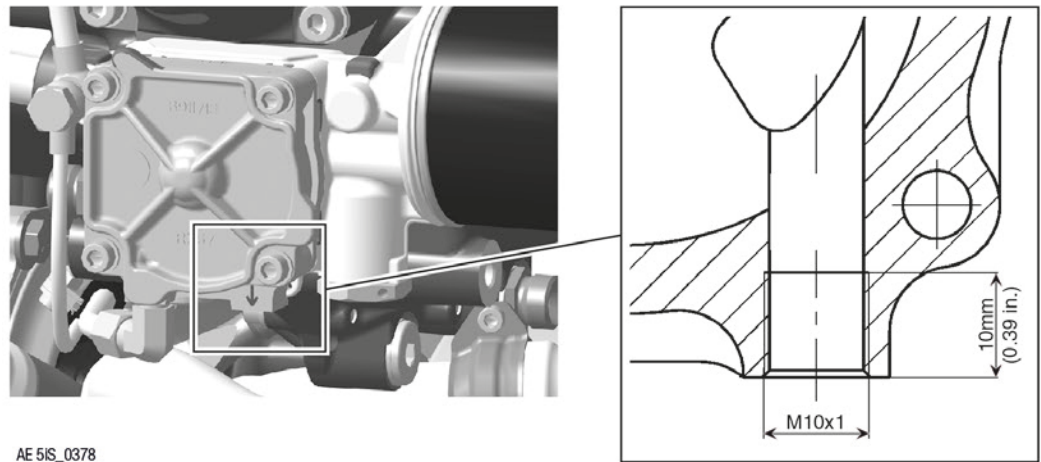

Figure 12.9: Oil return outlet (turbo charger)

# BRP-Rotax INSTALLATION MANUAL

## INSTALLATION NOTES

### General

The representation of components in this chapter which are not within scope of the delivery is only symbolic. The design shown in this chapter does not represent a specified execution but should support the understanding of the system.

The final design, the selection and specification of parts according to the respective applicable regulations, the consideration of the system limitations and interface description as well as the comprehension of the operating limits in every operational state is in the responsibility of the aircraft manufacturer.

The aircraft manufacturer has to make sure that the operating limits given in the Operators Manual (OM) can be supervised by the pilot. The execution of the installation must allow the operation of the engine according to the Operators Manual (OM).

# BRP-Rotax INSTALLATION MANUAL

## INSTALLATION OVERVIEW

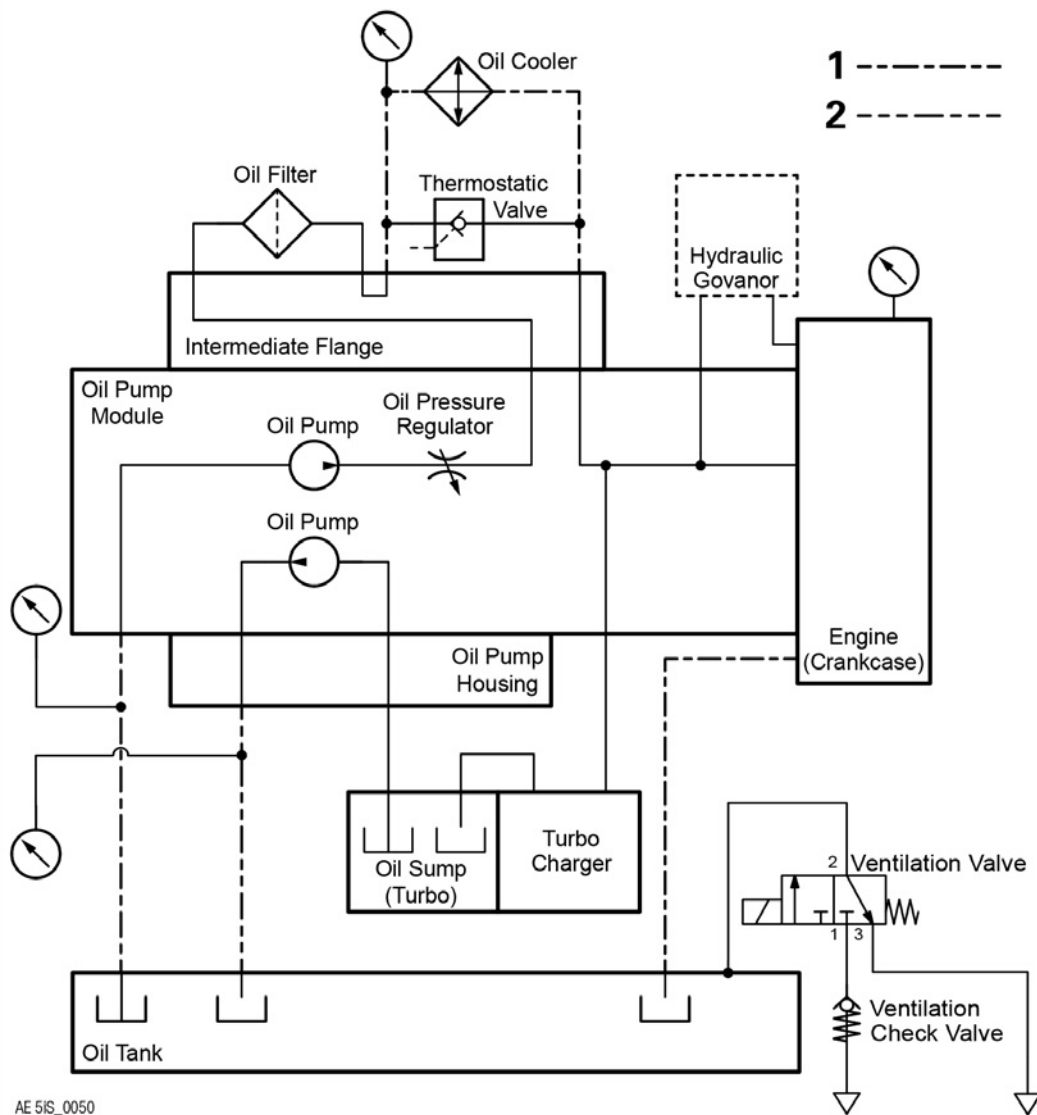

Figure 12.10: Lubrication system overview

1 Engine circuit

2 Turbocharger return line

## OIL THERMOSTAT

When operating at low temperatures the installation of an oil thermostat parallel to the oil cooler is highly recommended. The advantages are safe oil pressure after cold start and prevention of fuel and water accumulation in the oil.

# BRP-Rotax INSTALLATION MANUAL

## OIL LINES

At negative pressure of -500 mbar and a oil temperature of 140 °C (284 °F) the oil lines must not collapse.

A minimum inner diameter of at least 10 mm (0.39 in.) should be used.

### Oil tank venting line

Following points should be considered when installing the oil tank venting line:

- Route the line without kinks and avoid sharp bends
- Route the venting line in a continuous decline. Otherwise a drain bore at the lowest point should be foreseen to drain any condensate.

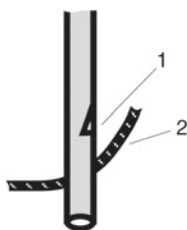

Figure 12.11: Bypass opening

1 Bypass opening      2 Cowling

### NOTE

*Water is a by-product of the combustion of fuel. Most of this water will dissipate from the combustion chamber with the exhaust gases. A small amount will reach the crankcase and must be disposed of through a venting line.*

*The venting line must be protected from any kind of ice formation for condensation by using e.g. isolation protection or a routing in a hose with hot air flow. Additionally a bypass opening should be installed before the cowling outlet.*

## OIL RADIATOR (OPTIONAL)

Essential parts of the cooling system, such as radiator, etc., are available for this engine from BRP-Rotax. See also SI-PAC-014.Oil radiator /-sets.

### **⚠ WARNING**

#### **Non-compliance can result in serious injuries or death!**

The furnishing of proof in accordance to the latest FAR and EASA, has to be conducted by the aircraft manufacturer.



**BRP-Rotax**  
INSTALLATION MANUAL

**Specifications of the oil radiator**

The radiator must be designed to dissipate approx. 30 kW (28.43 BTU/s) of thermal energy at take-off performance.

Weight: max. 0.82 kg (1.8 lb) for oil radiator “extra large”.

**NOTICE**

**The oil radiator must not restrict oil flow. Test system as per section “Checking the oil circuit”.**

# BRP-Rotax

## INSTALLATION MANUAL

### **FILLING AND PURGING THE OIL SYSTEM**

**Introduction** Ensure that oil lines are connected correctly and secured. Also ensure that the oil cooler (if fitted) is in the suction line between the oil tank and the oil pump, see following figure. Verify that the oil tank is filled up to the maximum level (to the top of the flat portion of the dipstick). The capacity of the oil system without oil cooler and connection lines is approx. 3l (0.79 gal.). Additional oil (up to 0.5 litres (0.13 gal)) may be added to the tank for the purpose of this procedure.

**Instruction** The following work procedures must be carried out for purging the oil system:

1. Disconnect oil return lines from the oil tank.
2. Place the free end of the return lines into a suitable container (4) below the engine.
3. Plug open connection on oil tank with suitable air tight caps.
4. Remove the spark plug connectors.
5. For easier rotation of engine remove one spark plug from each cylinder.

#### **NOTE**

Prevent any foreign objects entering the spark plug hole.

6. Using compressed air, pressurize the oil tank through its vent fitting (6) (on the neck of the tank). Adjust the compressor outlet regulator so that the air line pressure is between 0.4 bar (5.8 psi) and 1 bar (14.5 psi). Do not exceed 1 bar (14.5 psi).

#### **NOTE**

The oil tank cap is not pressure-tight, some air can escape.

7. Turn the engine by hand in direction of normal rotation until the first pressure indication appears on the oil pressure gauge. Normally this will take approx. 20 turns. Depending on installation it may take up to 60 turns.

#### **NOTE**

Do not use the starter for this purpose. Fit propeller and use it to turn the engine.

#### **NOTE**

The oil tank may empty and as a result introduce air into the oil system. Pay attention to the oil level and fill tank as required.

8. Stop the pressurization.
9. Open the caps for the oil return lines on the oil tank and reconnect the engine oil return lines to the tank. Ensure that the suction oil line and oil return lines are connected to the proper fittings on the oil tank. Note: If the oil lines from the engine to the oil tank are incorrectly connected, severe engine damage may result.
10. Re-fit the spark plug. Restore aircraft to original operating condition.
11. Residual oil may have accumulated in the crankcase. Return it to the oil tank by following the oil level check procedure in the relevant Operators Manual (OM).
12. Fill the oil in the tank up to the full mark on the dipstick.

# BRP-Rotax INSTALLATION MANUAL

13. Carefully check all lubrication system connections, lines and clamps for leaks and tightness.

## ENVIRONMENTAL NOTE

**Protect the environment! Do not spill oil and pay attention for adequate disposal.**

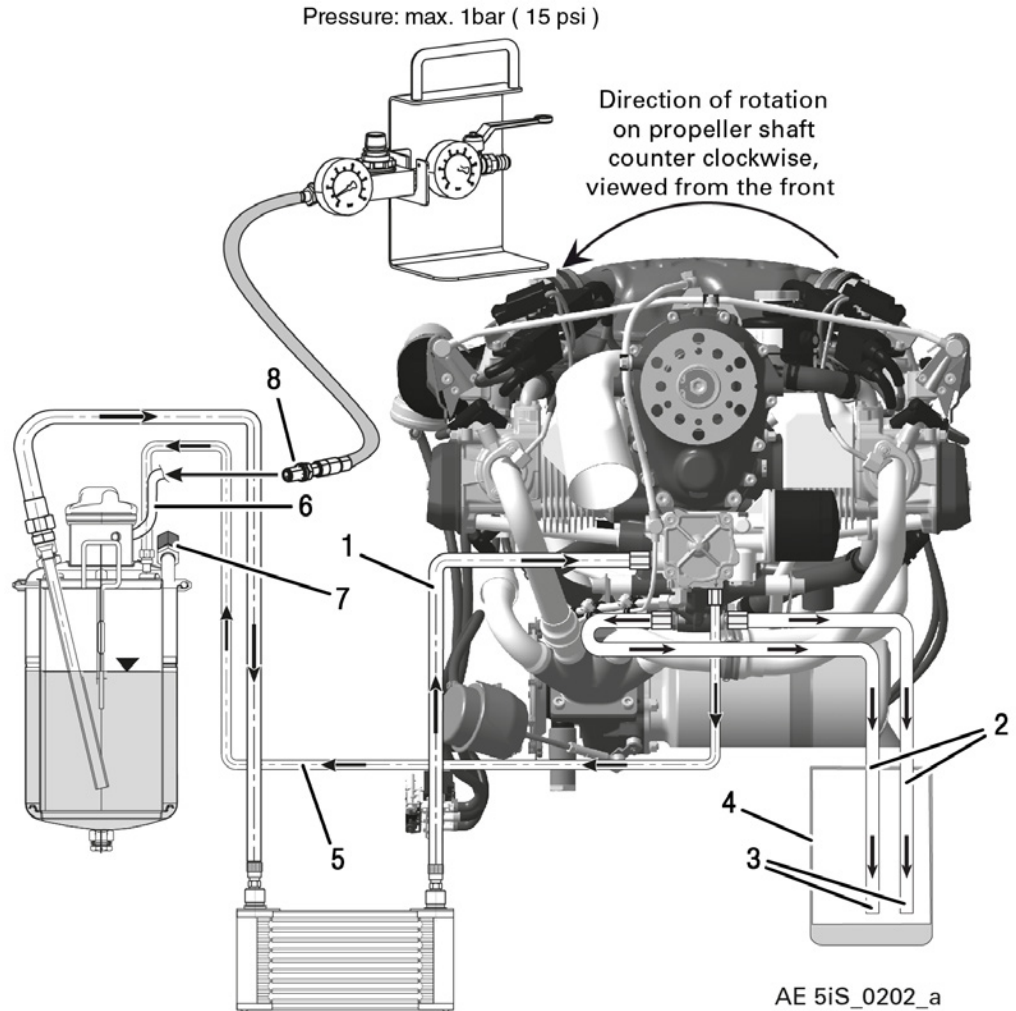

Figure 12.12: Setup for venting the oil system, TYPICAL

- |   |   |
|---|---|
| <p>1 Suction line</p> <p>3 Free end</p> <p>5 Oil return line (Turbocharger)</p> <p>7 2 x Screw socket (Oil inlet)</p> | <p>2 Oil return line</p> <p>4 Temporary oil collection tank</p> <p>6 Vent fitting</p> <p>8 Temporary connection for purging</p> |
|---|---|

# BRP-Rotax INSTALLATION MANUAL

## VALIDATION OF INSTALLATION

### General

The validation procedures described in this chapter do not claim to be complete. The correct execution and compliance with all given system limitations and interface descriptions as well as with standards and norms given by authorities must be proven by the aircraft manufacturer.

### CRANKCASE PRESSURE MEASUREMENT

1. Remove magnetic plug or crankshaft locking screw.
2. Attach pressure sensor (pressure gauge with liquid damping). The thread for the magnetic plug must be M12x1,5 (metric). The thread for the crankshaft lock pin hole must be M8.
3. Start the engine according the Operators Manual (OM) and read the crankcase pressure value at full throttle.
4. Compare the read out value with the limitations for the crankcase pressure specified in the section "System Limitations" of this chapter.  
If the readings exceed the pressure limits, then the flow resistance in the oil return line from oil sump to oil line is too high in the current engine installation (contamination, restrictions of cross-section etc.) This condition is unsafe and must be rectified immediately.
5. Re-install magnetic plug or screw into crankshaft locking pin hole. When reinstalling the screw always use a new gasket.

**BRP-Rotax**  
**INSTALLATION MANUAL**

**Chapter: 80-00-00**  
**STARTING**

**TOPICS IN THIS CHAPTER**

**System description** ..... **3**  
    System limitations ..... 3  
**Interface description** ..... **4**  
    Interface overview ..... 4  
    Electrical interfaces ..... 4  
**Installation notes** ..... **6**  
    Installation overview ..... 6  
    Wiring ..... 7  
**Starter relay assy. technical data** ..... **9**  
**Validation of installation** ..... **11**

**BRP-Rotax**  
INSTALLATION MANUAL

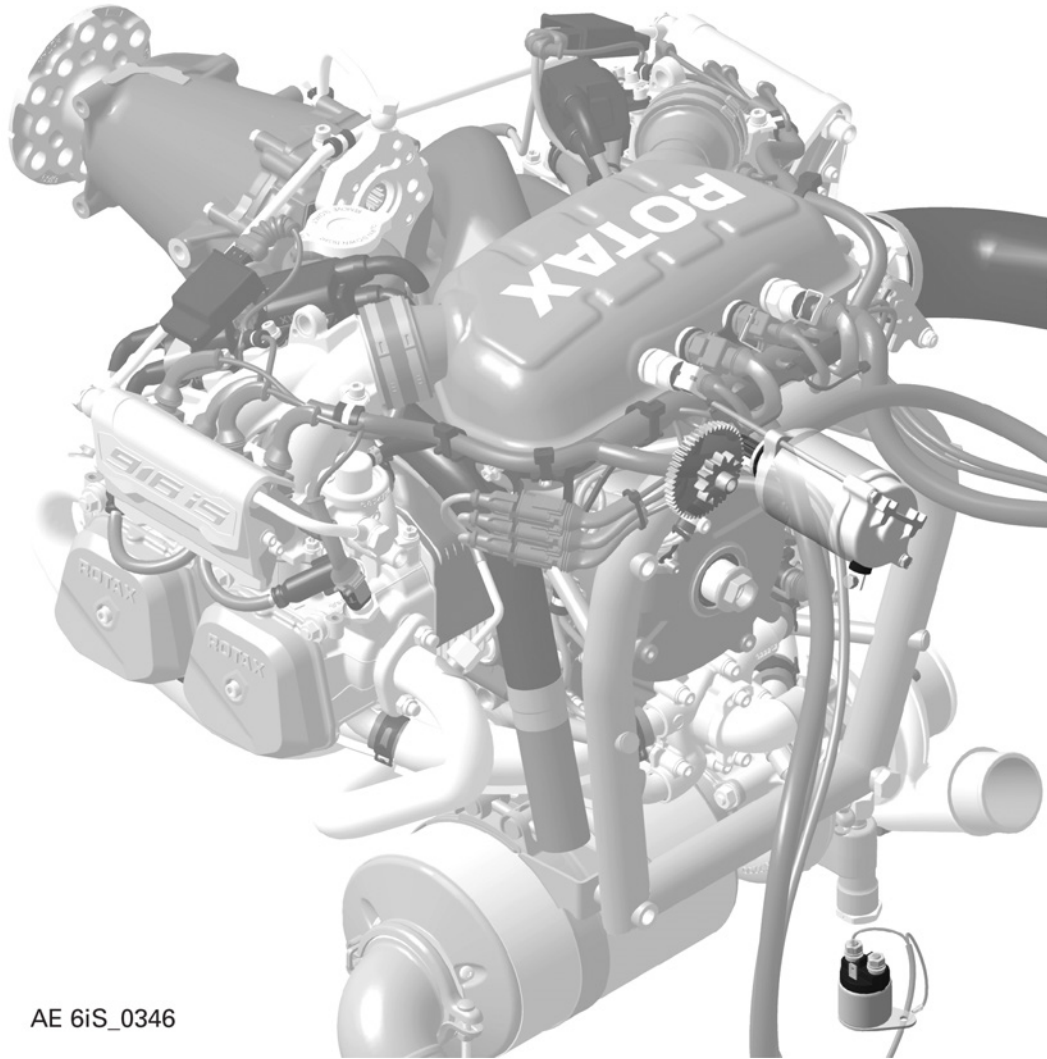

AE 6iS\_0346

Figure 13.1: Starting

**BRP-Rotax**  
INSTALLATION MANUAL

**SYSTEM DESCRIPTION**

For a detailed System description refer to the latest issue of the Operators Manual (OM).

**SYSTEM LIMITATIONS**

**Operating limits** Refer to latest issue of the Operators Manual (OM).

**Ambient temperatures**

System Limit	Min.	Max.
Electric Starter	- 40 °C (- 40 °F)	80 °C (176 °F)

**Thermal durability** Suitable for short starting periods only. Activate starter for max. 10 seconds (without interruption), followed by a cooling period of 2 minutes.

**Aircraft ground** The engine block must be connected to the aircraft using a properly sized ground strap (minimum the same cable cross section as starter supply), to provide the required starter current and to avoid static electricity between the engine and the aircraft.

# BRP-Rotax INSTALLATION MANUAL

## INTERFACE DESCRIPTION

### INTERFACE OVERVIEW

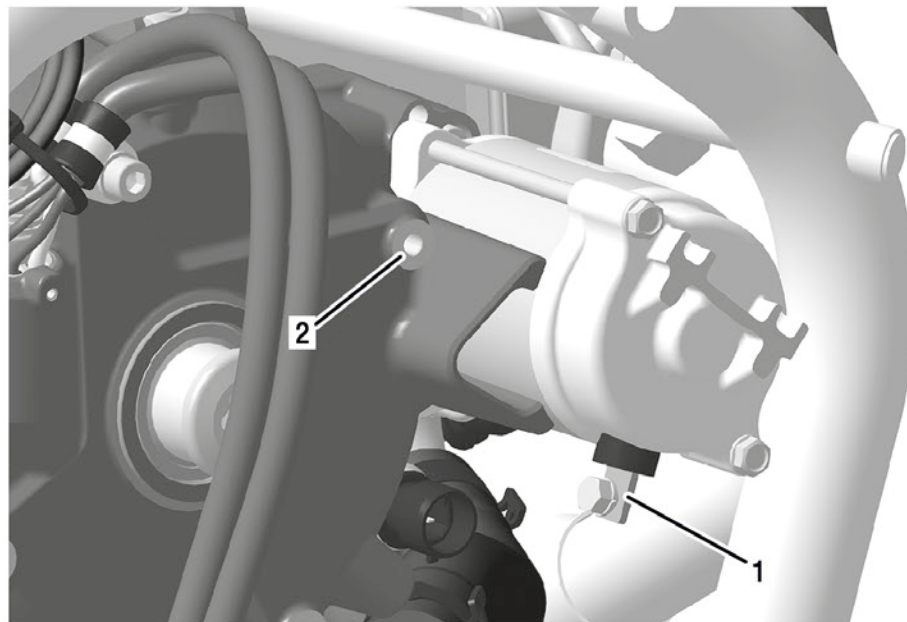

AE 516\_0036

Figure 13.2: Starter interfaces

1 Positive terminal

2 Negative terminal

### ELECTRICAL INTERFACES

Positive terminal

916 i TYPE A

Interface Parameter	Min.	Max.	Nominal
Input voltage:			12 V
Input load:*	20 A	350 A <sup>4</sup>	
* for resistance of starter circuit R <sub>smax</sub> = <20 mOhm			

The terminal must be conducted as M5 screw connection suitable for cable lug according to DIN 46225.

Tightening torque: Min. 3 Nm (27 in.lb) Max. 5 Nm (44 in.lb).

4. When electric starter is activated



# BRP-Rotax INSTALLATION MANUAL

## Positive terminal

### 916 i TYPE C24

Interface Parameter	Min.	Max.	Nominal
Input voltage:			24 V
Input load:* * for resistance of starter circuit R <sub>smax</sub> = <20 mOhm	20 A	350 A <sup>5</sup>	

The terminal must be conducted as M5 screw connection suitable for cable lug according to DIN 46225.

Tightening torque: Min. 3 Nm (27 in.lb) Max. 5 Nm (44 in.lb).

## Negative terminal

The engine block must be connected to the airframe using a properly sized ground strap (minimum the same cable cross section as the starter supply), for carrying the starter current and to avoid static electricity between the engine and the airframe.

---

## 5. When electric starter is activated

# BRP-Rotax INSTALLATION MANUAL

## INSTALLATION NOTES

### General

The representation of components in this chapter which are not within scope of the delivery is only symbolic. The design shown in this chapter does not represent a specified execution but should support the understanding of the system.

The final design, the selection and specification of parts according to the respective applicable regulations, the consideration of the system limitations and interface description as well as the comprehension of the operating limits in every operational state is in the responsibility of the aircraft manufacturer.

The aircraft manufacturer has to make sure that the operating limits given in the Operators Manual (OM) can be supervised by the pilot. The execution of the installation must allow the operation of the engine according to the Operators Manual (OM).

### INSTALLATION OVERVIEW

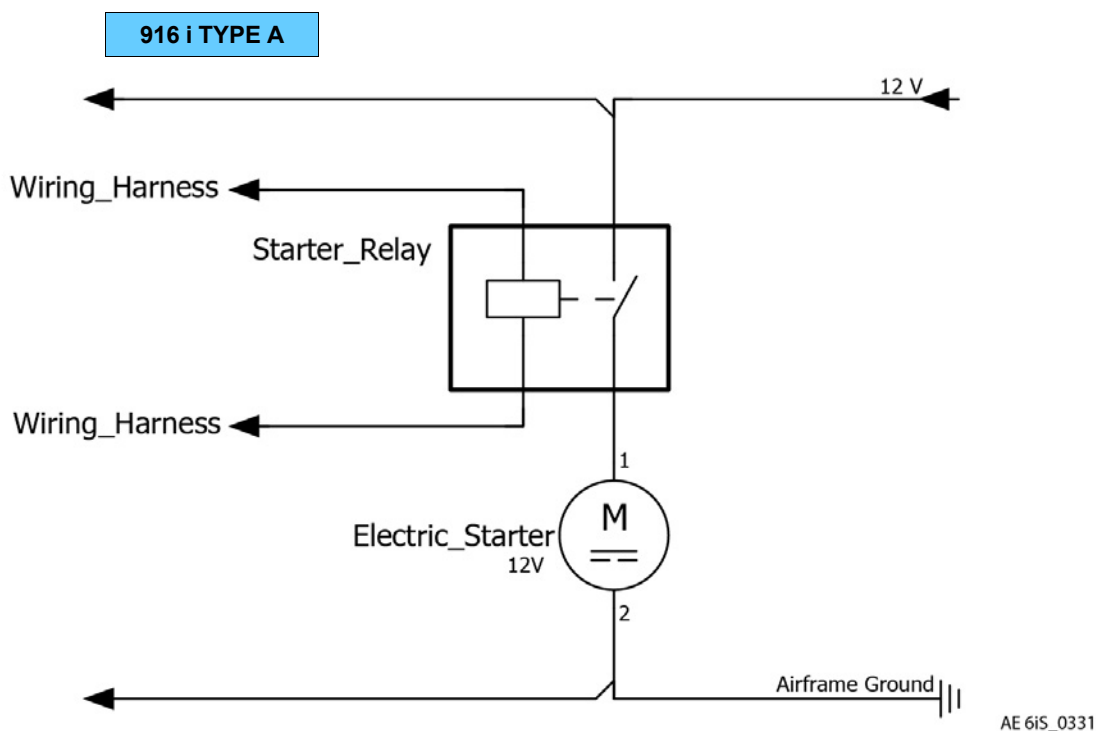

Figure 13.3: Engine starting circuit

# BRP-Rotax INSTALLATION MANUAL

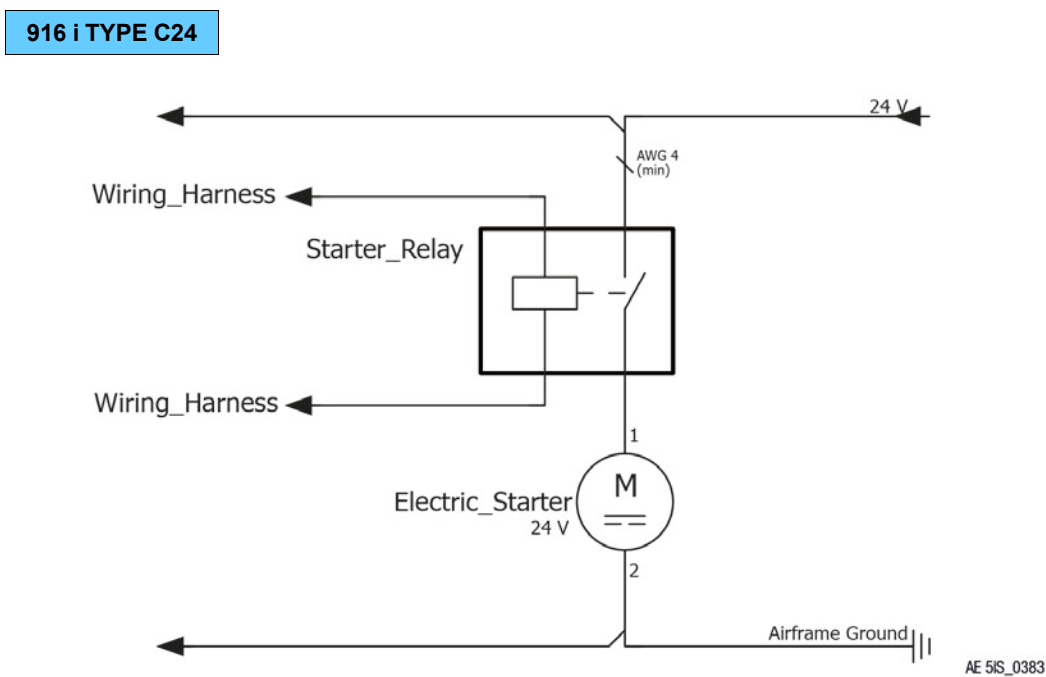

Figure 13.4: Engine starting circuit

## WIRING

The minimum cable cross-section for the line from the battery to the starter relay and from there to the electric starter and for the ground line (start system) depends on the cable length "l" (= Sum of the supply line and ground line of the electric starter) and is recommended to be calculated according to the following table.

l [m]	l [ft]	A <sub>min.</sub> [mm <sup>2</sup> ]	A <sub>min.</sub> [in <sup>2</sup> ]	A <sub>max.</sub> [mm <sup>2</sup> ]	A <sub>max.</sub> [in <sup>2</sup> ]	AWG <sub>min.</sub>
<4	<13	20.408	0.031	25	0.039	4
4<l<4.5	13<l<14.8	22.959	0.036	35	0.054	3
4.5<l<5	14.8<l<16.4	25.51	0.04	35	0.054	3
5<l<5.5	16.4<l<18	28.061	0.043	35	0.054	2
5.5<l<6	18<l<19.7	30.612	0.047	35	0.054	2
6<l<6.5	19.7<l<21.3	33.163	0.051	35	0.054	2
6.5<l<7	21.3<l<23	35.714	0.055	50	0.078	1
7<l<7.5	23<l<24.6	38.265	0.059	50	0.078	1
7.5<l<8	24.6<l<26.2	40.816	0.063	50	0.078	1
8<l<8.5	26.2<l<27.9	43.367	0.067	70	0.109	0
8.5<l<9	27.9<l<29.5	45.918	0.071	70	0.109	0

## BRP-Rotax INSTALLATION MANUAL

I [m]	I [ft]	A <sub>min.</sub> [mm <sup>2</sup> ]	A <sub>min.</sub> [in <sup>2</sup> ]	A <sub>max.</sub> [mm <sup>2</sup> ]	A <sub>max.</sub> [in <sup>2</sup> ]	AWG <sub>min.</sub>
9<l<9.5	29.5<l<31.2	48.469	0.075	70	0.109	0
9.5<l<10	31.2<l<32.8	51.02	0.079	70	0.109	0

The internal resistance of the battery and the resistance of the electrical system (wires, contact points, relay contacts) largely determine the performance of the starting system. Therefore, the total loop resistance ( $R_{Smax}$ ) may not exceed 0.015  $\Omega$ .

$$R_{Smax} = \sum R = R_{iBatt} + R_{C \text{ Starter relay}} + R_L + R_{Other}$$

Symbol	Description
$R_{iBatt}$	Inner resistance of battery
$R_{C \text{ Starter Relay}}$	Contact resistance starter relay
$R_L$	Line resistance
$R_{Other}$	Any other resistor (e.g. Master relay, contact resistance...)

**BRP-Rotax**  
**INSTALLATION MANUAL**

**STARTER RELAY ASSY. TECHNICAL DATA**

**NOTICE**

**Activation of starter relay limited to short duration. The duty cycle over an interval of 4 minutes is 25%.**

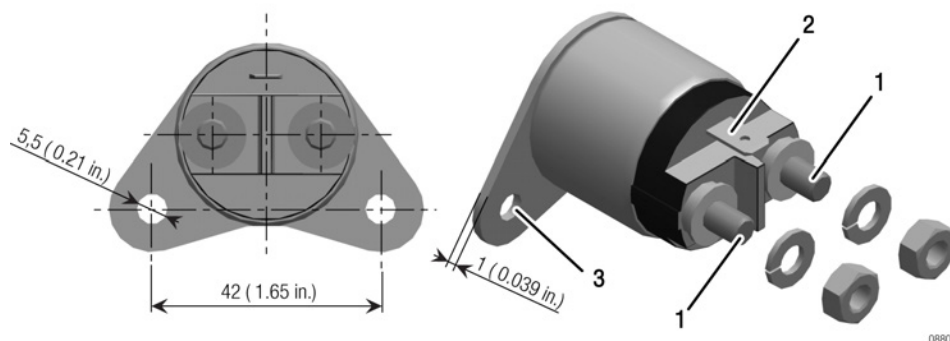

Figure 13.5: Starter relay

- 1 Main current connections
- 2 Control wiring
- 3 Mounting point

<b>Nominal voltage</b>	12 V/DC
<b>Control voltage</b>	min. 6 V / max. 18 V
<b>Switching current</b>	max. 75 A (permanent) max. 300 A/1 s (short duration)
<b>Permissible ambient temperature</b>	min. -40 °C (-40 °F) / max. +100 °C (212 °F)
<b>Weight</b>	See Chapter 72-00-00 section Weight.
<b>Main current connections</b>	M6 screw connection (tightening torque 4 Nm (36 in.lb.)) suitable for cable terminals according to DIN 46225 (MIL-T-7928; PIDG or equivalent).
<b>Control wiring</b>	6.3x0.8 plug connector suitable for Faston connector (female) according to DIN 46247 (MIL-T-7928; (PIDG) or equivalent).

**BRP-Rotax**  
INSTALLATION MANUAL

**Grounding**

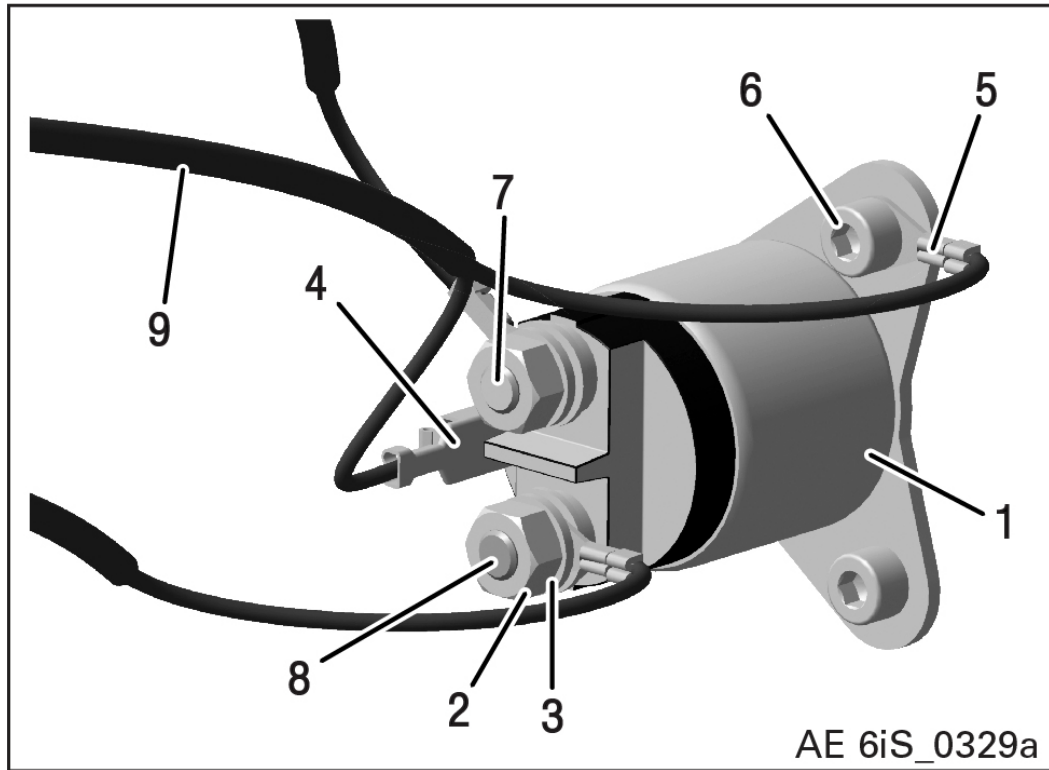

Figure 13.6: Starter relay

- |                           |               |
|---------------------------|---------------|
| 1 Starter relay           | 2 Hex. nut M6 |
| 3 Washer 6.4              | 4 Terminal S  |
| 5 Ground                  | 6 Bolt/screw  |
| 7 Terminal B              | 8 Terminal M  |
| 9 Wiring harness (Engine) |               |

**BRP-Rotax**  
INSTALLATION MANUAL

**VALIDATION OF INSTALLATION**

**General**

The validation procedures described in this chapter do not claim to be complete. The correct execution and compliance with all given system limitations and interface descriptions as well as with standards and norms given by authorities must be proven by the aircraft manufacturer.

**BRP-Rotax**  
INSTALLATION MANUAL

INTENTIONALLY LEFT  
BLANK



**BRP-Rotax**  
**INSTALLATION MANUAL**

**Chapter: 92-00-00**  
**WIRING DIAGRAMS**

**TOPICS IN THIS CHAPTER**

**General**

This Chapter contains the wiring diagrams for each relevant engine system installation.

The wiring diagrams have the same numbering system and abbreviations as used in this Manual

<b>Title</b>	<b>Drawing Number</b>	<b>Rev. Number</b>	<b>Number of Sheets</b>
Wiring diagram ROTAX® 916 i Type A	Z16855	0	1
Wiring diagram ROTAX® 916 i Type C24	Z17217	0	1

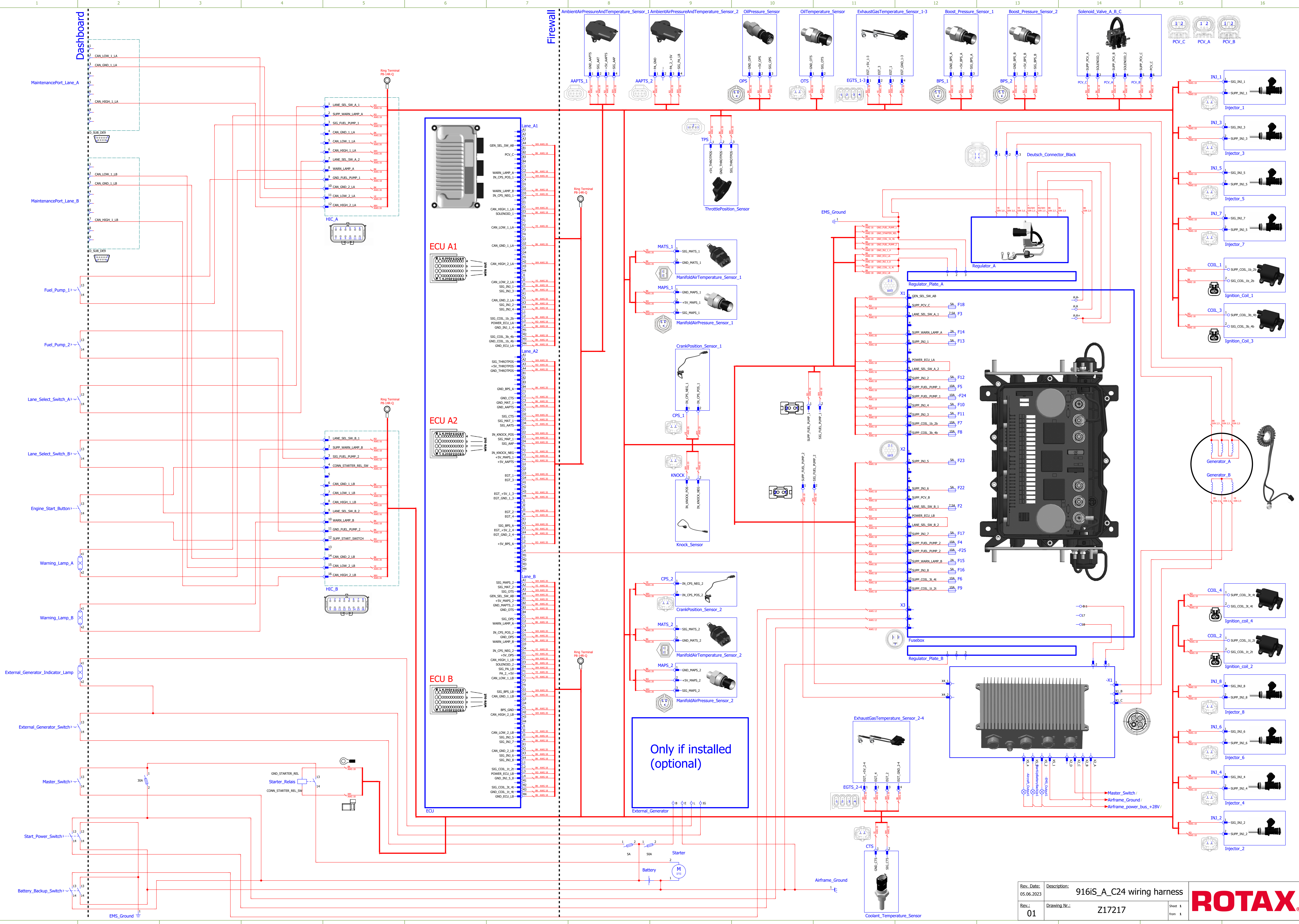

**BRP-Rotax**  
INSTALLATION MANUAL

INTENTIONALLY LEFT  
BLANK

# BRP-Rotax INSTALLATION MANUAL

## Index

### A

Abbreviations.....	6
Air cooling interfaces .....	7
Approval of electric and electronic components .....	19
Auxiliary equipment.....	5

### B

Battery .....	21
Bypass line.....	10

### C

CAN interfaces.....	15
CAN interfaces – 916 I Type C24.....	19
Coarse filter .....	11
Components.....	13
constant speed propeller.....	8
Control elements.....	22
Conversion table.....	12
Coolant .....	13
Coolant hoses.....	13
Coolant, Boiling point.....	13
Crankcase pressure measurement.....	3, 20

### E

Electrical interfaces .....	6, 9, 7, 11, 6, 4
Electrical interfaces – 916 I Type A .....	6
Electrical interfaces – 916 I Type C24 .....	13, 10
Engine suspension.....	13
Engine, Handling.....	5
Engine, Preservation .....	4
Engine, Storage .....	4
Engine, Unpacking .....	5
Exhaust tail pipe.....	5
Expansion tank .....	12

### F

Filling and purging the oil system.....	18
Fine filter .....	11
Fuel interfaces .....	6
Fuel lines.....	10
Fuel pressure regulator.....	12
Fuel pressure sensor.....	12

Fuel pump .....	12
Fuel shut off valve .....	13
Fuel system, overview .....	9
Fuel tank .....	12

### G

Gascolator.....	11
General.....	2
Grounding cables.....	20

### H

Handling the engine .....	9
---------------------------	---

### I

Inlet line.....	10
Installation notes .....	20, 8, 14
Installation overview .....	20, 10, 16, 18, 13, 15, 6
Installation overview – 916 I Type C24 .....	16
Instruction .....	16
Interface description .....	6, 12, 9, 6, 4
Interface overview .....	4, 6, 10, 5, 4, 8
Interface overview – 916 I Type C24 .....	9
Interface overview.– 916 I Type C24 .....	12

### L

Lane Select Switch.....	20
List of effective pages .....	1

### M

Measuring of the vacuum.....	5
Mechanical interfaces.....	11, 6, 9, 7, 14
Mechanical Interfaces.....	8
Mechanical interfaces – 916 I Type C24.....	18

### O

Oil hose, Requirements .....	7
Oil lines .....	16
Oil pressure sensor .....	1
Oil pump.....	11
Oil radiator.....	16

# BRP-Rotax INSTALLATION MANUAL

Oil tank interfaces .....	10	System Limitations .....	3
Oil thermostat .....	15		
<b>P</b>		<b>T</b>	
Pneumatic interfaces .....	8	Table of amendments .....	1
Positive terminal.....	4	Technical documentation .....	17
Propeller governor, hydraulic.....	8	Terms.....	6
Purging line, Requirements .....	7	Type description.....	3
<b>R</b>		<b>V</b>	
Return line.....	10	Validation of installation .....	28, 14, 20, 11
RTCA/DO-160 .....	19		
<b>S</b>		<b>W</b>	
Safety .....	13	Warning lamp .....	15
Safety information .....	14	Warning lamp – 916 I Type C24.....	19
Scope of supply .....	4	Water inlet elbow.....	12
Start switch.....	20	Water inlet, Water outlet.....	5
Starter relay, Technical data .....	9	Water trap.....	11
System description.....	4, 5	Wiring .....	7
System limitations .....	4, 3, 7, 3, 5, 4, 3	Wiring color codes.....	11
		Wiring diagrams.....	1



# ROTAX®

---

Engine serial no.

---

Type of aircraft

---

Aircraft registration no.

Rotax® authorized distributor

**FLYROTAX.COM**

® and TM are trademarks of BRP-Rotax GmbH & Co KG.

© 2023 BRP-Rotax GmbH & Co KG. All rights reserved.

